

## Short manual, Universal intermediate jaw UZB

### About this Short Manual

This short manual contains important details for the assembly and handling of the universal intermediate jaw UZB .

### Applicable documents

- General terms of business\*
- Catalog data sheet of the purchased product \*

The documents marked with an asterisk (\*) can be downloaded on our homepage [schunk.com](http://schunk.com)

### Scope of delivery

The scope of delivery includes

- Universal intermediate jaw UZB in the version ordered
- Accessory pack

### Personnel qualification

The following personal qualifications are necessary for the various activities related to the product:

#### Qualified personnel

Due to its technical training, knowledge and experience, qualified personnel is able to perform the delegated tasks, recognize and avoid possible dangers and knows the relevant standards and regulations.

### Intended use

This product is intended to be mounted on SCHUNK grippers and make a toolless adjustment of the gripping range possible.

- The product may only be used within the scope of its technical data.
- The product is intended for industrial and industry-oriented use.
- Appropriate use of the product includes compliance with all instructions in this manual.
- Any utilization that exceeds or differs from the appropriate use is regarded as misuse.

The following points are considered as misconduct:

- Use outdoor, in liquids and in potentially explosive atmospheres
- Use as clamping tool.

### Technical Data

Designation	UZB							
	40	50	64	80	100	125	160	200
Max. adjustment range [mm]	20	33	33	44	55	72	80	112
Grid dimension [mm]	1	1.5	1.5	2	2.5	3	4	7
Total weight [g]	40	70	110	170	260	350	620	1180
Weight slide [g]	*	*	*	100	140	180	300	520

\*) At this sizes the slide is an integral part.

More technical data is included in the catalog data sheet. Whichever is the latest version.

### Design and description

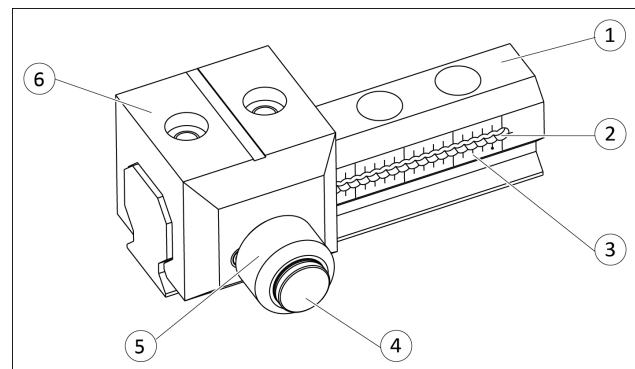

Design

1	Profile
2	Grid to adjust gripping range
3	Scale
4	Clamping bolt
5	Knurled nut to clamp position
6	Slide

By releasing the knurled nut the slide can be moved manually on the profil. A spring locked steel ball fix the slide in the grid. The setting position depends on the grid dimension. Therefore a fast, toolless adjustment on other part width is possible. From size 80 on the slide can be removed. Thereby a fast retooling to other gripping geometry is possible.

## Short manual, Universal intermediate jaw UZB

### Installing the product

**NOTE**

By selecting the mounting screws observe the SCHUNK specified values, see the following figure and table.

- Fix gripper fingers with screws and centering sleeves (3) on the slide.
  - ✓ Observe the max. screw-in depth.
- Fix product with screws (1) and centering sleeves (2) on the grip
  - ✓ Observe the tightening torque.

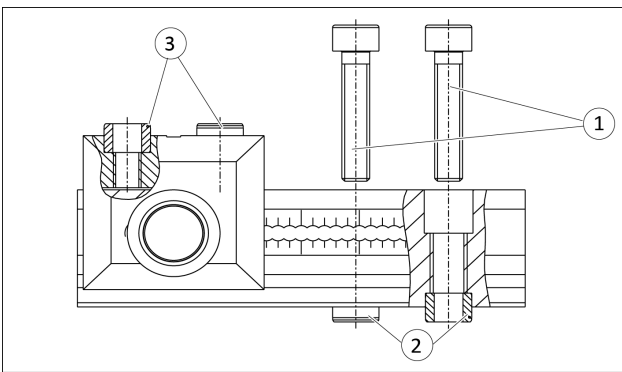

Possibilities of installing

Item	Mounting	UZB							
		40	50	64	80	100	125	160	200
<b>Side A</b> Fixing at the gripper									
1 *	Screw	M2.5	M3	M4	M5	M6	M6	M10	M12
	Standard bolt	DIN EN ISO 4762 strength class 12.9							
	Tightening torque [Nm]	1.2	2.1	5.3	11	18	18	85	150
2	Centering sleeve	∅4	∅5	∅6	∅8	∅10	∅10	∅14	∅16
<b>Side B</b> Fixing the gripping fingers									
4	Srew	M2.5	M3	M4	M5	M6	M6	M10	M12
	Max. screw-in depth [mm]	5.5	5.5	8.5	10	12	12	17	17
3 *	Centering sleeve	∅4	∅5	∅6	∅8	∅10	∅10	∅14	∅16

\*) Contains the accessories kit

### Adjusting the gripping range

- Release the knurled nut until the green O-Ring on the clamping bolt is visible. **NOTICE! Parts can be released and drop out, if the knurled nut is unscrew too far. Release the knurled nut only as far as needed to move the slide.**
- Snap slide in the required position.
- Check position on the scale. Note: The snap-in position of all intermediate jaws, mounted on the gripper have to be equal.
- Fix knurled nut by hand.
  - NOTICE! Don't use any tools to fix knurled nut.** Exception: If a defined tightening torque is required (depending on the person or process), tighten the knurled nut over the hexagon socket. For the tightening torque, see the following table.

	UZB							
	40	50	64	80	100	125	160	200
Max. tightening torque [Ncm], knurled nut	90	100	100	160	160	180	250	300

### Servicing the product

**⚠ WARNING**

**Risk of injury due to unexpected movements!**

If the power supply is switched on or residual energy remains in the system, components can move unexpectedly and cause serious injuries.

- Before starting any work on the product: Switch off the power supply and secure against restarting.
- Ensure that no residual energy remains in the system.

The product is maintenance-free. SCHUNK recommends to do the following maintenance work in regular intervals:

- Clean all parts thoroughly, check for damage and wear.
- Remove all coarse dirt and chips from the cavities in the product.

**NOTICE! All locking surfaces at the profil and slide must be free from grease and oil.**