



Assembly and Operating Manual

MMS 22-PI1-EX/MMSK 22-PI1-EX

Magnetic switch

Translation of Original Operating Manual

Hand in hand for tomorrow

Imprint

The sensor MEK-E22 is distributed exclusively by SCHUNK under the type designation MMS 22...-EX/MMSK 22...-EX.

Manufacturer:

Bernstein AG
Hans-Bernstein-Str. 1
32457 Porta Westfalica

Copyright:

This manual is protected by copyright. The author is SCHUNK SE & Co. KG.
All rights reserved.

Technical changes:

We reserve the right to make technical improvements.

Document number: 1566685

Version: 03.00 | 4/29/2025 | en-US

Dear Customer

Dear Customer,

Thank you for putting your trust in our products and our family-owned company, the leading technology supplier of robots and production machines.

Our team is always available to answer any questions on this product and other solutions. We look forward to your challenging questions. We will find a solution!

Best regards,

Your SCHUNK team

Customer Management

Tel. +49-7133-103-2503

Fax +49-7133-103-2189

cmg@de.schunk.com



Please read the operating manual in full and keep it close to the product.

Table of contents

1 General	4
1.1 About this manual.....	4
1.1.1 Presentation of Warning Labels	4
1.1.2 Applicable documents	4
1.1.3 Variants	4
1.2 Warranty	5
1.3 Scope of delivery.....	5
1.4 ATEX certification.....	5
2 Basic safety notes.....	6
2.1 Intended use.....	6
2.2 Inappropriate use	6
2.3 Environmental and operating conditions.....	6
2.4 Structural changes.....	6
2.5 Personnel qualification	7
3 Technical data	8
4 Assembly and settings	9
4.1 Special conditions for ATEX applications	9
4.2 Mechanical connection.....	9
4.3 Electrical connection.....	10
4.4 Installing and configuring the sensor	11
4.4.1 Installing the sensor	11
4.4.2 Installing and configuring the sensor in teach mode.....	12
5 Troubleshooting.....	14
5.1 Sensor not operating	14
5.2 Sensor is operating, but not as desired	14
6 EU Declaration of Conformity	15
6.1 MMS 22-PI1-S-M8-PNP-EX.....	16
6.2 MMSK 22-PI1-S-PNP-EX.....	17

1 General

1.1 About this manual

This manual contains important information for the safe, correct use of the product.

The manual is an integral part of the product and must be kept accessible by personnel at all times.

Personnel must have read and understood this manual before beginning any work. The observance of all safety notes in this manual is the precondition for all safe working.

1.1.1 Presentation of Warning Labels

To make risks clear, the following signal words and symbols are used for safety notes.

NOTICE

Material damage!

Information about avoiding material damage.

1.1.2 Applicable documents

- General terms and conditions *
- Catalog data sheet for the purchased product *
- Assembly and operating manual for the SCHUNK module on which the sensor is installed *

The documents labeled with an asterisk (*) can be downloaded from [schunk.com/downloads](https://www.schunk.com/downloads).

1.1.3 Variants

This operating manual applies to the following variations:

- MMS 22-PI1 ... EX
- MMSK 22-PI1 ... EX, cable version with open wire strands

1.2 Warranty

If the product is used as intended, the warranty is valid for 24 months from the date of delivery from the production facility under the following conditions:

- Refer to the applicable documents, ▶ 1.1.2 [4]
- Observe the ambient conditions and operating conditions, ▶ 2.3 [6]

1.3 Scope of delivery

The scope of delivery includes:

- Magnetic switch MMS 22-PI1-EX/MMSK 22-PI1-EX in the version ordered
- Assembly and Operating Manual
- Magnetic teaching tool, ID 301030

1.4 ATEX certification



II 2G Ex IIC T6 Gb
II 2D Ex tb IIC T85°C Db
KEMA 08ATEX0130 X

2 Basic safety notes

2.1 Intended use

The product (sensor) is used for sensing a position of a SCHUNK module via a magnetic control cam or a specific magnetic field.

- The product is intended for installation in a machine/ automated system. The applicable guidelines for the machine/ automated system must be observed and complied with.
- The product may only be used within the scope of its technical data, ▶ 3 [8].

2.2 Inappropriate use

The product is not a safety component in accordance with the EC Machine Directive 2006/42/EC and must not be used in safety-relevant parts of machine control units.

2.3 Environmental and operating conditions

Required ambient conditions and operating conditions

Incorrect ambient and operating conditions can make the product unsafe, leading to the risk of serious injuries, considerable material damage and/or a significant reduction to the product's life span.

- Make sure that the product is only used within its defined application parameters, ▶ 3 [8].
- Make sure that the environment is free from splash water and vapors as well as from abrasion or processing dust. Exceptions are products that are designed especially for contaminated environments.

2.4 Structural changes

Implementation of structural changes

Modifications, changes or reworking, e.g. additional threads, holes, or safety devices, can damage the product or impair its functionality or safety.

- Structural changes should only be made with the written approval of SCHUNK.

2.5 Personnel qualification

Inadequate qualification of personnel

Work on the product by inadequately qualified personnel can lead to serious injuries and considerable material damage.

- Order all work to be performed only by appropriately qualified personnel.
- Personnel must have read and understood the complete manual before beginning any work on the product.
- Observe national accident prevention regulations and the general safety notes.

3 Technical data

Designation	MMS 22-PI1-EX/ MMSK 22-PI1-EX
Ambient temperature [°C] (fixed-installed cable)	
Min.	- 20
Max.	+ 80
<hr/>	
Rated voltage [VDC]	24
Min.	10
Max.	30
<hr/>	
IP protection class (sensor is connected)	67
<hr/>	

For further technical data, see the catalog data sheet.

4 Assembly and settings

4.1 Special conditions for ATEX applications

The sensor should be installed so that it is protected from UV light, mechanical hazards, condensation and ingress of moisture. The sensor must be provided with a fuse that corresponds to the rated current. The breaking capacity of the fuse must correspond to the possible short circuit current of the supply source.

For MMS(K) 22-PI1...EX, the fixed connection cable should be connected in non-explosive areas or in a certified housing in compliance with an ignition protection type according to EN 60079-0 or in a certified housing according to EN 60079-31.

4.2 Mechanical connection

NOTICE

Property damage due to incorrect bending radius!

The product may get damaged if the cable's bending radius is less than the minimum.

- **Static:** 10 times the cable diameter.
- **Dynamic:** 15 times the cable diameter.

NOTICE

Risk of damage to the sensor during assembly!

- Observe the maximum tightening torque.

Ferromagnetic components change the sensor's switching positions, e. g. adapter plate made of construction steel. For ferromagnetic adapter plates:

- First, install the module on the adapter plate.
- Then adjust the switching position of the sensor.

NOTE

- Do not use the sensor as a safety component.
- Do not pull on the cable of the sensor.
- Secure the cable and connection plug so that they are not taugt and cannot move during operation.
- Do not exceed the permitted bending radius of the cable.
- Do not allow the sensor to come into contact with hard objects and chemicals (e. g., nitric acid, chromic acid and sulfuric acid).

The sensor is an electronic component that can be sensitive to high-frequency interference or electromagnetic fields.

- Check whether there is sufficient distance between the sensor and sources of interference and their supply cables.

4.3 Electrical connection

PNP					
Type of switching : PNP					
Switching function: closer					
Variant MMS 22-PI1 ... EX: Connector M8					
Variant MMSK 22-PI1 ... EX: 2 m cable, open wire strand					
1	Brown	Supply voltage	4	Black	Output
3	Blue	GND			

4.4 Installing and configuring the sensor

There are two possible ways of installing and configuring the sensor. Without teach mode, the sensor is installed as described in chapter ▶ 4.4.1 [11]. In the case of greater precision and hysteresis requirements, the sensor must be installed as described in chapter ▶ 4.4 [11] and configured in teach mode.

4.4.1 Installing the sensor

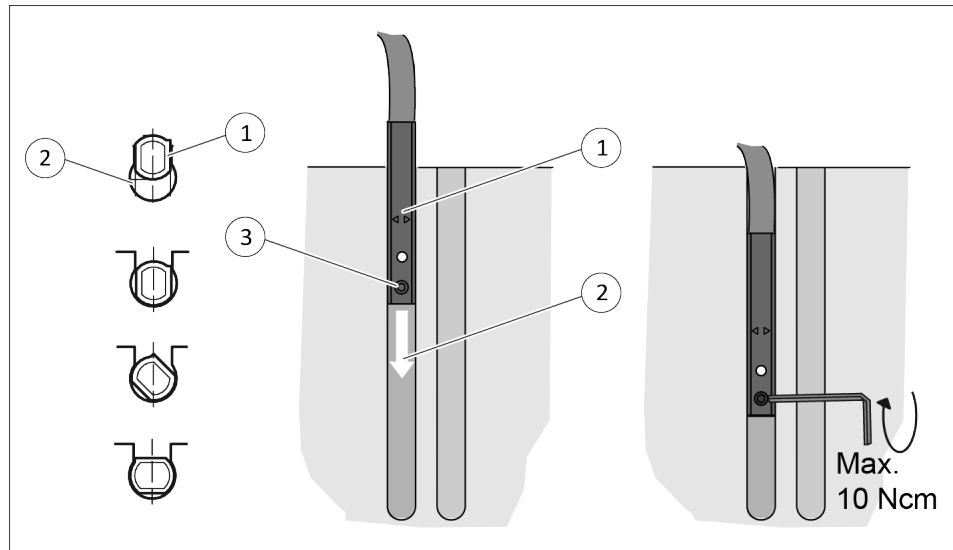

NOTE

The sensor is adjusted against the direction of motion of the magnet/control cam to be measured.

1. Place the monitored module in switching position.
2. Connect the sensor (1).
3. Push the sensor (1) into the groove (2) until it stops at the housing.
OR: Turn and push the sensor (1) into the groove (2) until it stops at the housing.
4. Pull the sensor (1) back again slowly until it operates (LED lights up).
5. Tighten the set-screw (3) to clamp the sensor (1) in this position in the groove (2).
⇒ Observe the maximum tightening torque of 10 Ncm.
6. Test the switching position.

4.4.2 Installing and configuring the sensor in teach mode

NOTE

The difference between the teach and operating temperatures must not exceed 30 K.

1. Place the sensor (1) in the groove (2) and in the specified position (see the Assembly and Operating Manual of the monitored module).
2. Tighten the set-screw (3) to clamp the sensor (1) in this position in the groove (2).
 - ⇒ Observe the maximum tightening torque of 10 Ncm.
3. Place the monitored module in switching position.
4. Place the magnet teach tool (MT) on the sensor (3) for at least 2 s.
 - Or:** Press the button (1) on the connector teach tool (ST) for at least 2 s.
 - ⇒ The LED (2) flashes after 2 s.
5. Remove the MT.
 - Or:** Release the button (1) on the ST.
6. Place the MT back on the sensor (3) for at least 0.3 s, then remove it.
 - Or:** Press the button (1) on the ST for at least 0.3 s and then release it.
7. Wait 2 s.
 - ⇒ The LED (2) lights up continuously.

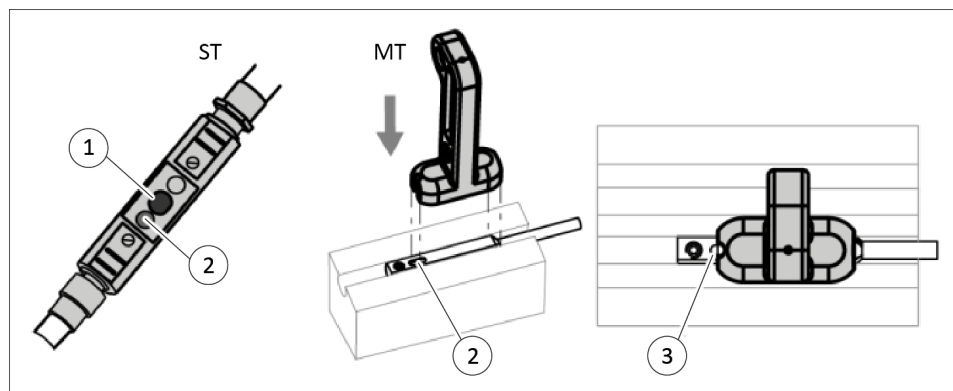

NOTE

The setting procedure is canceled after 30 s if the MT is not placed on the sensor again or the button (1) on the ST is not pressed. The LED (2) flashes quickly for 2 s if the magnetic field is too large or too small. If there is a duplicate or unsuitable switching point, the sensor (3) should be moved by 2 mm and taught again.

Displaying the optimal position

1. Place the monitored module in switching position.
2. Insert the sensor (1) into the groove in teach mode until the LED flashes quickly.

Setting the hysteresis

The switch-off point of the end position can be manually adjusted by adjusting the hysteresis.

A minimum and maximum hysteresis is defined based on the magnetic field. This defines the distance between the switch-on and switch-off point. The sensor prevents a hysteresis that is too low when the hysteresis is adjusted. If the switch-off point is taught too far away from the switch-on point, the switch-off position close to the switch-on point is automatically used. The switch-off point must then be taught closer to the switch-on point.

1. Place the module in "Switch-off point" position.
2. Place the MT on the sensor (3) for at least 5 s.
Or: Press the button (1) on the ST for at least 5 s.
 ⇒ The LED (2) flashes after 2 to 5 s and goes out.
3. Remove the MT quickly.
Or: Release the button (1) on the ST.
 ⇒ The LED (2) lights up to show the current switching point, otherwise the LED (2) flashes.
4. Place the MT back on the sensor (3) for at least 0.3 s, then remove it quickly.
Or: Press the button (1) on the CT for at least 0.3 s.
5. Wait 2 s.
 ⇒ After approximately 2 s, the LED (2) flashes twice if the magnetic field is not too large, otherwise it flashes quickly for 2 s.

NOTE

A minimum and maximum hysteresis is defined based on the magnetic field. This defines the distance between the switch-on and switch-off point. If the switch-off point is taught too far away from the switch-on point, the switch-off position close to the switch-on point is automatically used. In this case, the switch-off point closer to the switch-on point must be taught.

5 Troubleshooting

5.1 Sensor not operating

1. Check whether the sensor cable is broken.
2. Check whether the voltage at the sensor is within the permitted range, ▶ 3 [8].
3. Check whether the LED lights up at the position to be sensed and that the sensor is operating.

NOTE

If the LED does not light up or the sensor is not operating, contact SCHUNK Service.

5.2 Sensor is operating, but not as desired

Possible cause	Sources of interference	Remedial measures
The sensor is interfered with or influenced by external magnetic or soft magnetic materials (Fe).	Motors (coils)	Increase the distance between the sensor and sources of interference (until the sensor operates correctly).
	Relays	
	Linear motors	
	Electrical welding	Use finger attachments made of aluminum.
	Magnetized workpieces (workpieces made of iron (Fe) or similar materials)	
	Magnetized components and tools made of iron (adapter plates made, screws or hexagon socket keys, etc.)	Use components containing aluminum. V4A screws are recommended.
The sensor is influenced by a different sensor.	Same or similar product	Increase the distance between the sensors to at least 2 mm.
The sensor is affected by deposits of magnetic chips in the vicinity (in the air gap).	Liquids with magnetic chips or the like.	Regularly clean the immediate environment of the sensor. (The higher the exposure to such fluids, the more often it needs to be cleaned.)
The sensor is affected by the directly adjacent module.	Built-in magnets in the piston of the adjacent module	Increase the distance to the adjacent module to at least 10 mm.

NOTE

If these steps do not eliminate the problem, contact SCHUNK Service for troubleshooting.

6 EU Declaration of Conformity



EU-Konformitätserklärung / EU Declaration of Conformity / Déclaration UE de

Conformité

Diese Konformitätserklärung entspricht der europäischen Norm DIN EN ISO/IEC 17050-1:
Konformitätsbewertung – Konformitätserklärung von Anbietern – Teil 1: Allgemeine Anforderungen. Die Grundlage der Kriterien sind internationale Dokumente, insbesondere ISO/IEC-Leitfaden 22, 1982, Informations on manufacturer's declaration of conformity with standards or other technical specifications. Die deutsche Sprachfassung ist die Originalkonformitätserklärung. Bei anderen Sprachen handelt es sich um die Übersetzung der Originalkonformitätserklärung.

This Declaration of Conformity is suitable to the European Standard EN ISO/IEC 17050-1:
Conformity assessment – Supplier's declaration of conformity – Part 1: General requirements. The basis for the criteria has been found in international documentation, particularly in: ISO/IEC Guide 22, 1982, Informations on manufacturer's declaration of conformity with standards or other technical specifications. The original Declaration of Conformity is the German language version. Other languages are a translation of the original Declaration of Conformity.

Cette déclaration de conformité correspond au Norme Européenne EN ISO/IEC 17050-1: Évaluation de la conformité – Déclaration de conformité du fournisseur – Partie 1: Exigences générales. La base des directives sont des documents internationaux répondant à ISO/IEC-Guide 22, 1982, Informations on manufacturer's declaration of conformity with standards or other technical specifications. La version allemande est la langue d'origine de la déclaration de conformité. Les autres langues ne sont qu'une traduction de la déclaration de conformité en langue allemande.

Wir / We / Nous

BERNSTEIN AG

(Name des Anbieters) / (Supplier's name) / (Nom du fournisseur)

**Hans-Bernstein-Straße 1
D-32457 Porta Westfalica**

(Anschrift) / (Address) / (Adresse)

Hinweis:

Der Vertrieb erfolgt exklusiv durch die Firma SCHUNK
SCHUNK GmbH & Co.KG
Bahnhofstraße 106-134
D-74348 Lauffen / Neckar

erklären in alleiniger Verantwortung, dass das (die) Produkt(e):
declare under our sole responsibility that the product(s):
déclarons sous notre seule responsabilité que le(s) produit(s):

MEK-E22PS/HP1-KL0,3S8EX Artikelnummer 647.2281.176

Der Vertrieb erfolgt durch die Fa. Schunk unter der Typenbezeichnung:

MMS 22-PI1-S-M8-PNP-EX Artikelnummer 1001354

(Bezeichnung, Typ oder Modell, Los-, Chargen- oder Serien-Nr., möglichst Herkunft und Stückzahl)
(Name, type or model, batch or serial number, possibly sources and number of items)
(Nom, type ou modèle, n° de lot, d'échantillon ou de série, éventuellement les sources et le nombre d'exemplaires)

mit folgenden Europäischen Richtlinien übereinstimmt (übereinstimmen):
is (are) in conformity with the following directives:
est (sont) conforme(s) aux directives européennes:

ATEX-Richtlinie 2014/34/EU

Dies wird nachgewiesen durch die Einhaltung folgender Norm(en):
This is documented by the accordance with the following standard(s):
Notre justification est l'observation de la (des) norme(s) suivante(s):

**EN IEC 60079-0:2018, EN 60079-18:2015/A1:2017,
EN 60079-31:2014
EX-Kennzeichnung gemäß: II 2G Ex IIC T6 Gb bzw. II 2 D Ex tb IIC
T85 °C Db
ATEX-Zertifikat-Nr.: KEMA 08ATEX0130X**

Porta Westfalica, 2025-01-14

(Ort und Datum der Ausstellung)
(Place and date of issue)
(Date et lieu)

i.V. Wolfgang Vogt
Compliance Officer Product

(Name, Position, Unterschrift)
(Name, status, signature)
(Nom, fonction, signature)



EU-Konformitätserklärung / EU Declaration of Conformity / Déclaration UE de Conformité

Diese Konformitätserklärung entspricht der europäischen Norm DIN EN ISO/IEC 17050-1:
Konformitätsbewertung – Konformitätserklärung von Anbietern – Teil 1: Allgemeine Anforderungen. Die Grundlage der Kriterien sind internationale Dokumente, insbesondere ISO/IEC-Leitfaden 22, 1982, Informations on manufacturer's declaration of conformity with standards or other technical specifications. Die deutsche Sprachfassung ist die Originalkonformitätserklärung. Bei anderen Sprachen handelt es sich um die Übersetzung der Originalkonformitätserklärung.

This Declaration of Conformity is suitable to the European Standard EN ISO/IEC 17050-1:
Conformity assessment – Supplier's declaration of conformity – Part 1: General requirements. The basis for the criteria has been found in international documentation, particularly in: ISO/IEC Guide 22, 1982, Informations on manufacturer's declaration of conformity with standards or other technical specifications. The original Declaration of Conformity is the German language version. Other languages are a translation of the original Declaration of Conformity.

Cette déclaration de conformité correspond au Norme Européenne EN ISO/IEC 17050-1: Évaluation de la conformité – Déclaration de conformité du fournisseur – Partie 1: Exigences générales. La base des directives sont des documents internationaux répondant à ISO/IEC-Guide 22, 1982, Informations on manufacturer's declaration of conformity with standards or other technical specifications. La version allemande est la langue d'origine de la déclaration de conformité. Les autres langues ne sont qu'une traduction de la déclaration de conformité en langue allemande.

Wir / We / Nous

BERNSTEIN AG

(Name des Anbieters) / (Supplier's name) / (Nom du fournisseur)

**Hans-Bernstein-Straße 1
D-32457 Porta Westfalica**

(Anschrift) / (Address) / (Adresse)

Hinweis:

Der Vertrieb erfolgt exklusiv durch die Firma SCHUNK
SCHUNK GmbH & Co.KG
Bahnhofstraße 106-134
D-74348 Lauffen / Neckar

erklären in alleiniger Verantwortung, dass das (die) Produkt(e):
declare under our sole responsibility that the product(s):
déclarons sous notre seule responsabilité que le(s) produit(s):

MEK-E22PS/HP1-KL2EX Artikelnummer 647.2281.177

Der Vertrieb erfolgt durch die Fa. Schunk unter der Typenbezeichnung:

MMSK 22-PI1-S-PNP EX Artikelnummer 1001355

(Bezeichnung, Typ oder Modell, Los-, Chargen- oder Serien-Nr., möglichst Herkunft und Stückzahl)
(Name, type or model, batch or serial number, possibly sources and number of items)
(Nom, type ou modèle, n° de lot, d'échantillon ou de série, éventuellement les sources et le nombre d'exemplaires)

mit folgenden Europäischen Richtlinien übereinstimmt (übereinstimmen):
is (are) in conformity with the following directives:
est (sont) conforme(s) aux directives européennes:

ATEX Richtlinie 2014/34/EU

Dies wird nachgewiesen durch die Einhaltung folgender Norm(en):
This is documented by the accordance with the following standard(s):
Notre justification est l'observation de la (des) norme(s) suivante(s):

**EN IEC 60079-0: 2018, EN 60079-18:2015/A1:2017,
EN 60079-31:2014
EX-Kennzeichnung: II 2G Ex IIC T6 Gb bzw. II 2 D Ex tb IIC
T85 °C Db
ATEX-Zertifikat-Nr.: KEMA 08ATEX0130X**

Porta Westfalica, 2025-01-14

(Ort und Datum der Ausstellung)
(Place and date of issue)
(Date et lieu)

**i.V. Wolfgang Vogt
Compliance Officer Product**

(Name, Position, Unterschrift)
(Name, status, signature)
(Nom, fonction, signature)

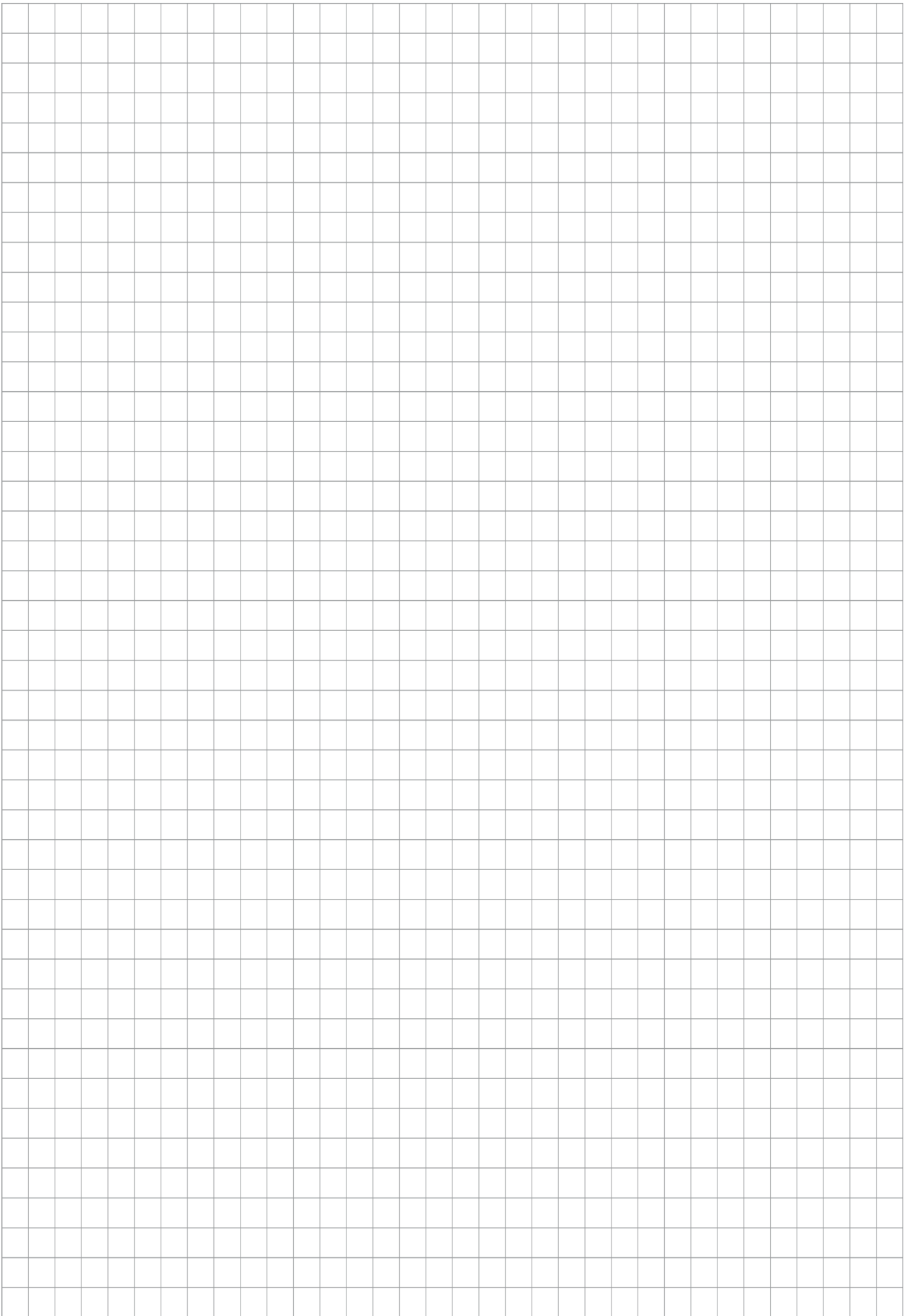

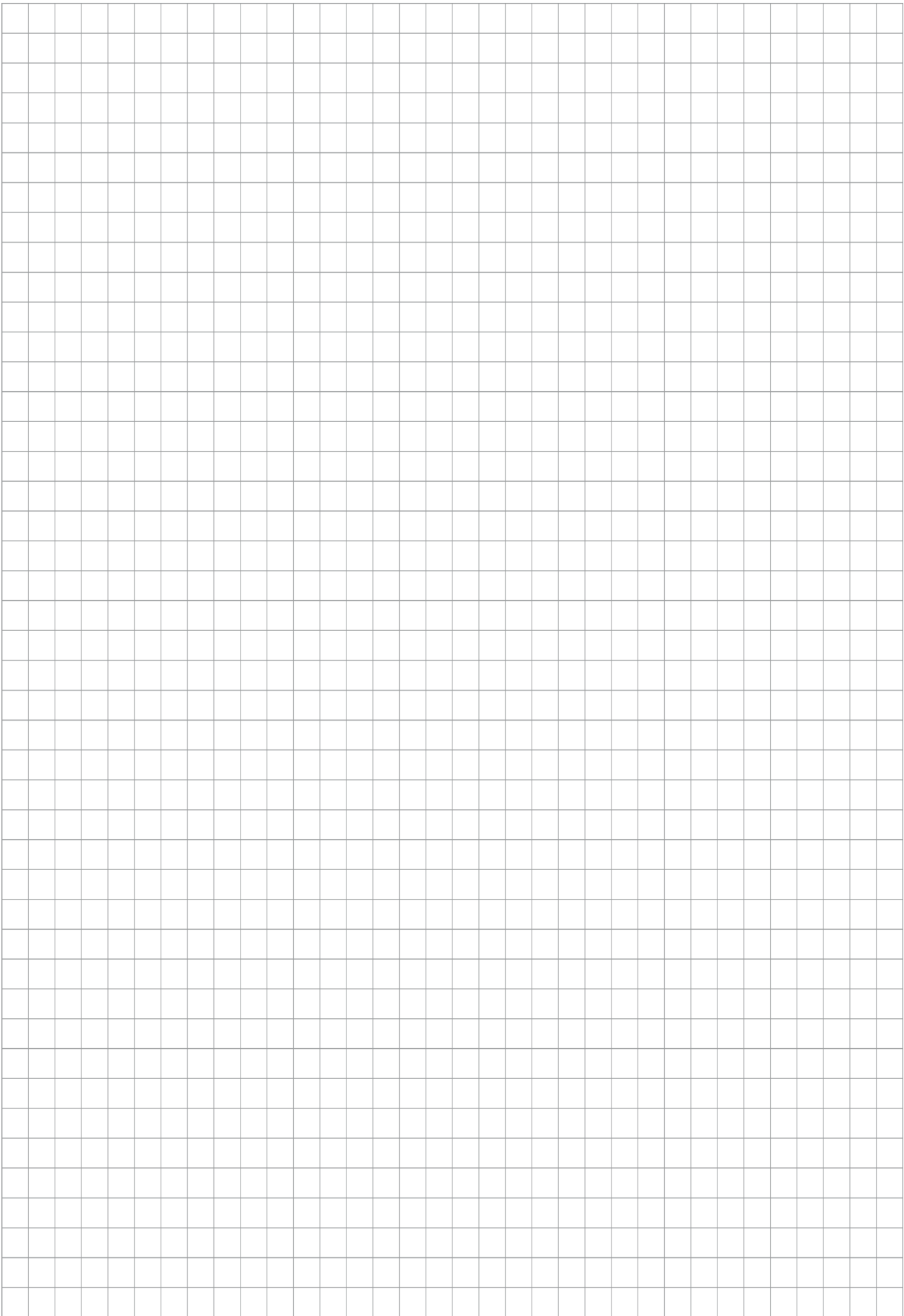



SCHUNK SE & Co. KG
Spanntechnik | Greiftechnik | Automatisierungstechnik

Bahnhofstr. 106 - 134
D-74348 Lauffen/Neckar
Tel. +49-7133-103-0
info@de.schunk.com
schunk.com

Folgen Sie uns | *Follow us*



Wir drucken nachhaltig | *We print sustainable*