



Assembly and Operating Manual

Co-act EGP-C

Electrical small components gripper for collaborative operations

Translation of Original Operating Manual

Hand in hand for tomorrow

Imprint

Copyright:

This manual is protected by copyright. The author is SCHUNK SE & Co. KG.
All rights reserved.

Technical changes:

We reserve the right to make alterations for the purpose of technical improvement.

Document number: 389336

Version: 19.00 | 10/09/2025 | en

Dear Customer,

Thank you for trusting our products and our family-owned company, the leading technology supplier of robots and production machines.

Our team is always available to answer any questions on this product and other solutions. Ask us questions and challenge us. We will find a solution!

Best regards,

Your SCHUNK team

Customer Management

Tel. +49-7133-103-2503

Fax +49-7133-103-2189

cmg@de.schunk.com



Please read the operating manual in full and keep it close to the product.

Table of Contents

1 General	5
1.1 About this manual	5
1.1.1 Presentation of Warning Labels	5
1.1.2 Definition of Terms	6
1.1.3 Applicable documents	6
1.1.4 Sizes	6
1.1.5 Variants	7
1.2 Warranty	7
1.3 Scope of delivery	8
1.4 Accessories	8
2 Basic safety notes	9
2.1 Appropriate use	9
2.2 Product safety	9
2.3 Obligations of the operator/integrator	10
2.4 Constructional changes	14
2.5 Gripper fingers	14
2.6 Environmental and operating conditions	15
2.7 Personnel qualification	15
2.8 Personal protective equipment	16
2.9 Notes on safe operation	17
2.10 Transport	17
2.11 Malfunctions	18
2.12 Disposal	18
2.13 Fundamental dangers	18
2.13.1 Protection during handling and assembly	19
2.13.2 Protection against dangerous movements	19
2.13.3 Protection against electric shock	20
3 Technical data	21
3.1 Name plate	21
3.2 Type key	22
3.3 Connection data	23
3.4 Ambient conditions and operating conditions	25
4 Design and description	26
4.1 Design	26
4.2 Description	26
4.3 Display	27
5 Assembly and settings	28

5.1	Installing and connecting	28
5.2	Mechanical connection.....	28
5.2.1	Install gripper fingers.....	33
5.3	Electrical connection.....	34
5.3.1	Connection assignment	34
5.3.2	Actuation	44
5.4	Adjust gripping force.....	46
5.4.1	Size 40 and 64.....	46
5.5	Adjust the sensors	47
5.5.1	Size 40.....	47
6	Start-up	48
7	Troubleshooting.....	49
7.1	Product does not move.....	49
7.2	Product does not execute a complete stroke.....	49
7.3	Product opens or closes jerkily	49
7.4	Gripping force too low.....	49
7.5	Opening and closing times are not achieved	50
7.6	Electric signals are not transmitted?	50
7.7	Faults which are displayed via LED Error	50
7.8	Acknowledge error	50
8	Maintenance	51
9	EU-Declaration of Conformity	52
10	UKCA declaration of Conformity	53
11	Translation of the original declaration of incorporation	54
12	UKCA declaration of incorporation	55
13	Information on the RoHS Directive, REACH Regulation and Substances of Very High Concern (SVHC)	56
14	Appendix	57
14.1	Commissioning checklist	57

1 General

1.1 About this manual

This manual contains important information for a safe and appropriate use of the product.

This manual is an integral part of the product and must be kept accessible for the personnel at all times.

Before starting work, the personnel must have read and understood this operating manual. Prerequisite for safe working is the observance of all safety instructions in this manual.

In addition to these instructions, the documents listed under ▶ 1.1.3 [6] are applicable.

NOTE: The illustrations in this manual are intended to provide a basic understanding and may deviate from the actual version.

1.1.1 Presentation of Warning Labels

To make risks clear, the following signal words and symbols are used for safety notes.



⚠ DANGER

Dangers for persons!

Non-observance will inevitably cause irreversible injury or death.



⚠ WARNING

Dangers for persons!

Non-observance can lead to irreversible injury and even death.



⚠ CAUTION

Dangers for persons!

Non-observance can cause minor injuries.

NOTICE

Material damage!

Information about avoiding material damage.

1.1.2 Definition of Terms

The term "product" replaces the product name on the title page in this manual.

1.1.3 Applicable documents

- General terms of business *
- Catalog data sheet of the purchased product *
- **Variant-URID, UREK:** Software Manual "SCHUNK Software module for URcap, Co-act EGP-C in UREK/URID variants" *
- **Variant-FCRXEK, FCRXID:** Software Manual "SCHUNK software module for FANUC CRX, Co-act EGP-C in the variants FCRXEK / FCRXID" *
- **Variante GoFa:** Software Manual "SCHUNK Softwarebaustein für ABB, Co-act EGP-C für ABB Robotics" *
- DGUV certificate, certificate no. MF 17007 *
- Assembly and operating manuals of the accessories *

The documents labeled with an asterisk (*) can be downloaded from [schunk.com/downloads](https://www.schunk.com/downloads).

1.1.4 Sizes

This operating manual applies to the following sizes:

- Co-act EGP-C 40
- Co-act EGP-C 64

1.1.5 Variants

This operating manual applies to the following variations:

- Co-act EGP-C KTOE (KUKA iiwa, media flange touch, electrical)
- Co-act EGP-C KMFE (KUKA iiwa, media flange, electrical)
- Co-act EGP-C URID (Universal Robots, NPN, with feed-through)
- Co-act EGP-C UREK (Universal Robots, external cabling)
- Co-act EGP-C TMID (Techman Robot, NPN, with feed-through)
- Co-act EGP-C TMEK (Techman Robot, external cabling)
- Co-act EGP-C FCR7 (FANUC CR-7 iA, connection via EE interface)
- Co-act EGP-C CR15 (FANUC CR-15iA, external cabling)
- Co-act EGP-C FCRXID (FANUC CRX, with feed-through)
- Co-act EGP-C FCRXEK (FANUC CRX, external cabling)
- Co-act EGP-C AUBO (AUBO Robotics i5, with feed-through)
- Co-act EGP-C SCR35 (SIASUN SCR 3 and SCR 5, with feed-through)
- Co-act EGP-C HCR (Hanwha Collaborative Robots, with feed-through)
- Co-act EGP-C M1013 (DOOSAN Robot, with feed-through)
- Co-act EGP-C ASSISTA (Mitsubishi Assista, external cabling)
- Co-act EGP-C GoFa (ABB GoFa™ - CRB 15000, with lead-through)

1.2 Warranty

If the product is used as intended, the warranty is valid for 24 months from the ex-works delivery date under the following conditions:

- Observe the ambient conditions and operating conditions, ▶ 3.4 [□ 25]
- Observe the specified maintenance intervals, ▶ 8 [□ 51]

Parts touching the workpiece and wear parts are not included in the warranty.

1.3 Scope of delivery

The scope of delivery includes

- Electrical small components gripper for collaborative operations Co-act EGP-C in the version ordered
- Assembly and Operating Manual
- Accessory pack

1.4 Accessories

The following accessories, which are to be ordered separately, are available for the product:

- Gripper fingers

For information regarding which accessory articles can be used with the corresponding product variants, see catalog data sheet.

2 Basic safety notes

2.1 Appropriate use

The product is designed exclusively for gripping and temporarily holding workpieces or objects.

- The product may only be used within the scope of its technical data, ▶ 3 [□ 21].
- The product is intended for installation in a machine or as an end effector of a robot, including for HRC (human-robot collaboration) applications. The applicable guidelines must be observed and complied with.
- The product is intended for industrial and industry-oriented use. Its use outside enclosed spaces is only permitted if suitable protective measures are taken against outdoor exposure. The product is not suitable for use in salty air.
- The product can be used within the permissible load limits and technical data for holding workpieces during simple machining operations, but is not a clamping device according to EN 1550:1997+A1:2008.
- Appropriate use of the product includes compliance with all instructions in this manual.
- Any utilization that exceeds or differs from the appropriate use is regarded as misuse.

2.2 Product safety

The product represents the state of the art and the recognized safety rules. However, the product can pose hazards if, for example:

- the product is not used as intended,
- the product is not installed or maintained properly,
- the safety and installation instructions are not observed,
- the safety application conditions (SAC) are not observed, or safety regulations of the equal value are not taken into account, see chapter ▶ 2.3 [□ 11] or
- the power supply fails or is changed.

Notes on power supply failure

When power is lost, the gripper fingers of the product can move freely, and their ability to maintain a hold on the load is not guaranteed. Therefore, the integrator or operator must ensure that releasing the load can not pose any hazard.

- Avoid any manner of working that may interfere with the function and operational safety of the product.

2.3 Obligations of the operator/integrator

The operator / integrator must ensure that:

- the product is only used as intended,
- the product is only operated in an impeccable, functional condition and is regularly inspected to make sure it is working properly,
- the operating manual is always available in a legible condition and in its entirety at the machine's application location
- only sufficiently qualified and authorized personnel operate and maintain the product,
- this personnel is regularly trained in all relevant questions relating to operational safety and environmental protection, and is familiar with the operating manual, particularly the safety information contained therein.

In particular, the operator / integrator must ensure that the following requirements and instructions for safe operation with a robot are met.

NOTE

Safety is only guaranteed if the following safety application conditions (SAC) are met.

Alternatively, the integrator/operator can implement their own risk-reducing measures and evaluate them as part of their risk analysis. Implementation of a risk analysis is vital in any event.

The following SACs are divided into **general SAC-Gs** and **product-specific SAC-Ps**.

- **SAC-Gs** refer to the interface of the product to or on the overall system. Since the configuration of the overall SCHUNK system is not known, these SAC-Gs are usually provided as a recommendation.
SAC-Gs that are not indicated below as a recommendation, must be followed or replaced by equivalent risk-mitigating measures.
- **SAC-Ps** refer to the product Co-act EGP-C and must be complied with or replaced by equivalent risk-mitigating measures.

SAC	Content
SAC-05-G	The integrator must ensure that the safety of the robot system is verified in accordance with the standards/sections of standards applicable to the defined application.
SAC-06-G	For the operation of the product within a robot system, separate safety checks must be carried out for the other components of the robot system (e.g. robot arm, gantry, or manipulator). These safety checks, the product's safety check/certificate of conformity, and the process of taking into account the applicable safety application rules for the entire system (measures for risk reduction from the risk assessment of the overall system), serve as reference checks for integrating the robot system. ⇒ For additional information, see chapter: ▶ 6 [48]
SAC-07-G	The integrator must ensure that any dangerous contact with moving parts of the robot cell is eliminated. ⇒ For additional information, see chapter: ▶ 2.13.2 [19]
SAC-08-G	The integrator must ensure that in the event of a collision within the robot system (e.g. with the robot arm, gripper, workpiece), the robot system is able to reliably detect the collision and respond accordingly.
SAC-09-G	The integrator must specify/observe the settings for commissioning the robot. ⇒ For additional information, see chapter: ▶ 6 [48] ▶ 14.1 [57]
SAC-10-G	The integrator must ensure that the product is only used within the scope of its technical data. ⇒ For additional information, see chapter: ▶ 3 [21] ▶ 3.4 [25] ▶ 2.9 [17]
SAC-11-G	Robots should be equipped with a visual display that indicates when the robot is in collaborative operation mode.
SAC-12-G	The integrator must carefully observe the shape of the workpiece, gripping force, alignment when the workpiece is gripped, travel height, path and speed of the product in order to minimize the risk of workpiece loss. ⇒ For additional information, see chapter: ▶ 14.1 [57]
SAC-03-P	Only clean and decommission the product when it is switched off. ⇒ For additional information, see chapter: ▶ 2.13 [18]

SAC	Content
SAC-04-P	<p>As part of the risk analysis of the overall system, a maximum permissible workpiece weight must be determined for the application. Important factors here are workpiece parameters such as shape and weight, as well as application parameters, such as travel height and speed. This maximum approved workpiece weight must not be exceeded.</p> <hr/> <p>⇒ For additional information, see chapter: ▶ 3 [21]</p>
SAC-05-P	<p>Any accidental, unnecessary or unintentional activation of the product must be prevented.</p> <hr/> <p>⇒ For additional information, see chapter: ▶ 2.13.1 [19] ▶ 2.13.2 [19]</p>
SAC-06-P	<p>To ensure inherent safety levels, it is necessary to take into account the structural design of the fingers:</p> <ul style="list-style-type: none"> • If possible, the gripper fingers should be designed so that unintentional engagement with the gripper fingers is not possible. • The gripper fingers may not have sharp edges or rough surfaces that could pose a hazard. • The relevant requirements (e.g. BG Recommendations, ISO/TS 15066, etc.) must be observed. Compliance with bio-mechanical limits must be verified. • If this is not possible, the integrator / operator must undertake further risk mitigation measures. <hr/> <p>⇒ For additional information, see chapter: ▶ 2.5 [14] ▶ 14.1 [57]</p>
SAC-07-P	<p>The design of the gripper fingers must allow positive gripping to minimize the risk of loss of the workpiece in a de-energized state. If this is not possible, the integrator / operator must undertake further risk mitigation measures.</p> <hr/> <p>⇒ For additional information, see chapter: ▶ 2.5 [14]</p>
SAC-08-P	<p>The integrator must bear in mind that a drop in the supply voltage could lead to workpiece loss.</p> <hr/> <p>⇒ For additional information, see chapter: ▶ 3 [21]</p>

SAC	Content
SAC-09-P	<p>This product is not designed for handling hot or cold workpieces. When handling hot or cold workpieces, heat transfer to the product must be prevented, which may result in the ambient temperature falling below or exceeding the permissible contact temperature. You can find further information in ISO 13732-1/-3.</p> <hr/> <p>⇒ For additional information, see chapter: ▶ 3 [📄 21]</p> <hr/>
SAC-10-P	<p>The product may become damaged if in contact with acidic or alkaline substances.</p> <hr/> <p>⇒ For additional information, see chapter: ▶ 3.4 [📄 25]</p> <hr/>
SAC-11-P	<p>The integrator must ensure that the product is grounded. For this purpose, the mechanical connection must be made electrically conductive.</p> <hr/> <p>⇒ For additional information, see chapter: ▶ 5.2 [📄 28] ▶ 2.13.3 [📄 20]</p> <hr/>
SAC-12-P	<p>The product is equipped with a safety fuse as a safety component, which may not be replaced under any circumstances. Send products to SCHUNK for repair.</p> <hr/>

2.4 Constructional changes

Implementation of structural changes

Via modifications, changes and reworking, e.g. additional threads, holes, or safety devices can impair the functioning or safety of the product or damage it.

- Structural changes should only be made with the written approval of SCHUNK.
- Only use the product with the collision protection cover installed by SCHUNK.

2.5 Gripper fingers

Requirements for the gripper fingers

Accumulated energy can make the product unsafe and risk the danger of serious injuries and considerable material damage.

- Only change gripper fingers if no residual energy can be released.
- Make sure that the product and the top jaws are a sufficient size for the application.
- When operating the robotic system without a protective fence, the gripper fingers must be designed so that bio-mechanical limits are not exceeded, e. g. upon contact between gripper fingers and persons or the workplace.

Compliance with bio-mechanical limits must be verified by the integrator.

- Design the radii and surfaces of the gripper fingers so that they comply with the requirements of collaborative workstations (e. g. BG/BGIA recommendations for risk assessment in accordance with the Machine Directive "Designing workstations with collaborating robots").

Notes and examples for designing the gripper fingers

- All edges should be rounded – including in the Z direction. If possible, make roundings greater than 5 mm.
- If possible, ensure form fitting.
- If possible, implement elastic workpiece parts or elastic inlays.

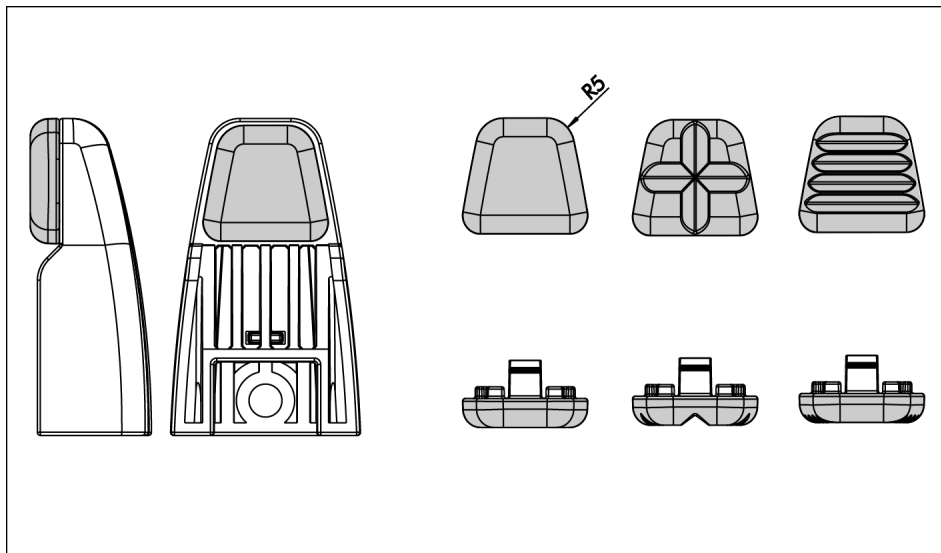

Examples of gripper finger shapes

2.6 Environmental and operating conditions

Required ambient conditions and operating conditions

Incorrect ambient and operating conditions can make the product unsafe, leading to the risk of serious injuries, considerable material damage and/or a significant reduction to the product's life span.

2.7 Personnel qualification

Inadequate qualifications of the personnel

If the personnel working with the product is not sufficiently qualified, the result may be serious injuries and significant property damage.

- All work may only be performed by qualified personnel.
- Before working with the product, the personnel must have read and understood the complete assembly and operating manual.
- Observe the national safety regulations and rules and general safety instructions.

The following personal qualifications are necessary for the various activities related to the product:

Trained electrician	Due to their technical training, knowledge and experience, trained electricians are able to work on electrical systems, recognize and avoid possible dangers and know the relevant standards and regulations.
Qualified personnel	Due to its technical training, knowledge and experience, qualified personnel is able to perform the delegated tasks, recognize and avoid possible dangers and knows the relevant standards and regulations.
Instructed person	Instructed persons were instructed by the operator about the delegated tasks and possible dangers due to improper behaviour.
Service personnel of the manufacturer	Due to its technical training, knowledge and experience, service personnel of the manufacturer is able to perform the delegated tasks and to recognize and avoid possible dangers.

2.8 Personal protective equipment

Use of personal protective equipment

Personal protective equipment serves to protect staff against danger which may interfere with their health or safety at work.

- When working on and with the product, observe the occupational health and safety regulations and wear the required personal protective equipment.
- Observe the valid safety and accident prevention regulations.
- Wear protective gloves to guard against sharp edges and corners or rough surfaces.
- Wear heat-resistant protective gloves when handling hot surfaces.
- Wear protective gloves and safety goggles when handling hazardous substances.
- Wear close-fitting protective clothing and also wear long hair in a hairnet when dealing with moving components.

2.9 Notes on safe operation

Incorrect handling of the personnel

Incorrect handling and assembly may impair the product's safety and cause serious injuries and considerable material damage.

- Avoid any manner of working that may interfere with the function and operational safety of the product.
- Use the product as intended.
- Observe the safety notes and assembly instructions.
- Do not expose the product to any corrosive media. This does not apply to products that are designed for special environments.
- Eliminate any malfunction immediately.
- Observe the care and maintenance instructions.
- Observe the current safety, accident prevention and environmental protection regulations regarding the product's application field.

What to do in an emergency

- In the event of an emergency, disconnect the product from the power supply and manually move the gripper fingers to the "gripper open" position.

2.10 Transport

Handling during transport

Incorrect handling during transport can make the product unsafe and risk the danger of serious injuries and considerable material damage.

- During transport and handling, secure the product to prevent it from falling.
- Do not walk under suspended loads.

2.11 Malfunctions

Behavior in case of malfunctions

- Immediately remove the product from operation and report the malfunction to the responsible departments/persons.
- Order appropriately trained personnel to rectify the malfunction.
- Do not recommission the product until the malfunction has been rectified.
- Test the product after a malfunction to establish whether it still functions properly and no increased risks have arisen.

What to do in an emergency

- In the event of an emergency, disconnect the product from the power supply and manually move the gripper fingers to the "gripper open" position.

2.12 Disposal

Handling of disposal

The incorrect handling of disposal may impair the product's safety and cause serious injuries as well as considerable material and environmental harm.

- Follow local regulations on dispatching product components for recycling or proper disposal.

2.13 Fundamental dangers

General

- Observe safety distances where they were defined in the risk assessment by the integrator / operator.
- Never deactivate safety devices.
- Disconnect power sources before installation, modification or calibration. Ensure that no residual energy remains in the system.
- Do not reach into the movement area of the product during operation.

2.13.1 Protection during handling and assembly

Incorrect handling and assembly

Incorrect handling and assembly may impair the product's safety and cause serious injuries and considerable material damage.

- Have all work carried out by appropriately qualified personnel.
- For all work, secure the product against accidental operation.
- Observe the relevant accident prevention rules.
- Use suitable assembly and transport equipment and take precautions to prevent jamming and crushing.

Incorrect lifting of loads

Falling loads can cause serious injuries and even death.

- Do not step under or within the swivel range of suspended loads, as determined by the integrator / operator as part of the risk analysis.
- Never move loads without supervision.
- Do not leave suspended loads unattended.

2.13.2 Protection against dangerous movements

Unexpected movements

Residual energy in the system may cause serious injuries while working with the product.

- EMERGENCY STOP switches must be easily and quickly accessible. Before commissioning the machine or automated system, check that the EMERGENCY STOP system is working. Prevent operation of the machine if this protective equipment does not function correctly.

2.13.3 Protection against electric shock

Working on electrical equipment

Touching live parts can lead to death.

- Work on electrical equipment may only be carried out by qualified electricians in accordance with electrotechnical regulations.
- Lay electrical cables properly, e.g. in a cable duct or cable bridge. Observe standards.
- Before connecting or disconnecting electrical cables: Switch off the power supply and secure it against being switched on again, check that the cables are de-energized.
- Before switching on / commissioning the product, check that the protective earth conductor is correctly attached to all electrical components in accordance with the wiring diagram.
- Check whether covers and protective devices have been fitted to prevent contact with live components.
- Do not touch the connection points of the product when the power supply is switched on.

The previous section contains the requirements from SAC-11-P, ▶ 2.3 [11]

Possible electrostatic energy

Components or assembly groups may become electrostatically charged. When the electrostatic charge is touched, the discharge may trigger a shock reaction leading to injuries.

- The operator must ensure that all components and assembly groups are included in the local potential equalisation in accordance with the applicable regulations.
- While paying attention to the actual conditions of the working environment, the potential equalisation must be implemented by a specialist electrician according to the applicable regulations.
- The effectiveness of the potential equalisation must be verified by executing regular safety measurements.

3 Technical data

3.1 Name plate

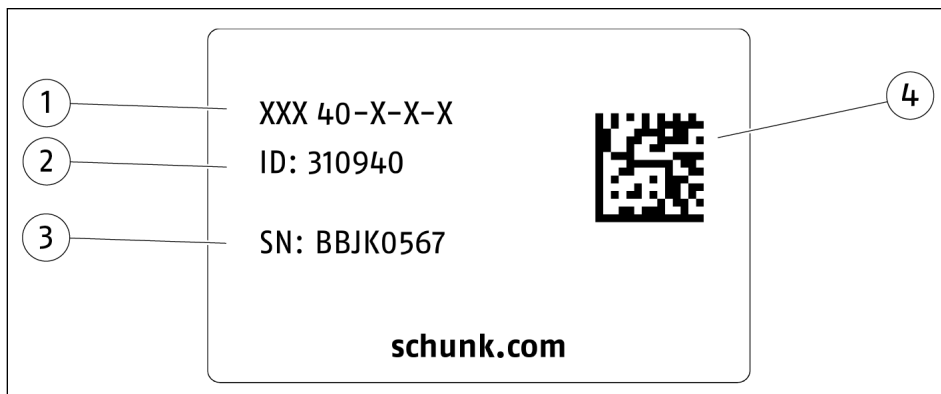

1 Product designation

2 ID

3 Serial number

4 Data matrix code

Scan code or enter serial number on the web and get all the product information: operating manuals, spare parts packages, software updates and much more.

For further information, visit [schunk.com/serialisierung](https://www.schunk.com/serialisierung)

A separate app may be required for scanning with a mobile phone.

3.2 Type key

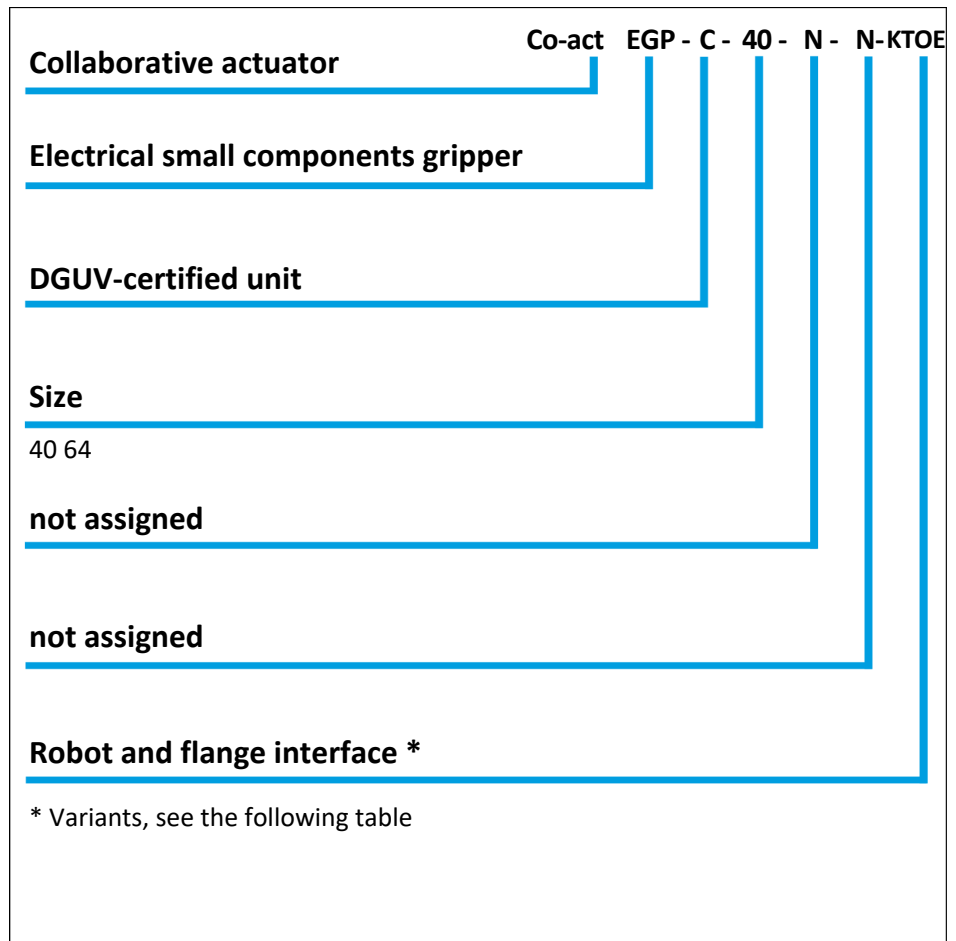

Product variant	Robot and adapter plate interface
FCR7	FANUC CR-7 iA connection via EE interface
FCRXID	FANUC CRX 10-iA, CRX 10-iA/L with feed-through (electr. tool interface)
FCRXEK	FANUC CRX 10-iA, CRX 10-iA/L external cabling
CR15	FANUC CR-15iA external cabling
KTOE	KUKA iiwa media flange touch electric
KMFE	KUKA iiwa media flange electric
URID	Universal Robots with feed-through (electr. tool interface)
UREK	Universal Robots external cabling
TMID	Techman Robot with feed-through (electr. tool interface)
TMEK	Techman Robot external cabling
AUBO	AUBO Robotics i5 with feed-through (electr. tool interface)

Product variant	Robot and adapter plate interface
SCR35	SIASUN SCR 3 and SCR 5 with feed-through (electr. tool interface)
HCR	Hanwha Collaborative Robots with feed-through (electr. tool interface)
M1013	DOOSAN Robot with feed-through (electr. tool interface)
ASISSTA	Mitsubishi ASSISTA external cabling
GoFa	ABB Robotics GoFa™ – CRB 15000 with lead-through (electr. tool interface)

NOTE

The product's ID number is located on the name plate. The catalog data sheet contains the assignment of the ID number of the listed product variants.

3.3 Connection data

Size 40

Designation	Value Co-act EGP-C 40
Supply voltage [VDC]	24
Min. [VDC]	21.6
Max. [VDC]	26.4
Min. Supply current power supply unit [A] *	
• Variant: FCR7, URID, UREK	1.0
• Variant: KTOE, FCRXID, FCRXEK, TMID, TMEK, M1013, AUBO, HCR, SCR35, ASSISTA, GoFa	1.0
• Variant: CR15	-
Max. Current input [A]**	
• Variant: FCR7, UREK	2.0
• Variant: URID	0.6
• Variant: TMID, AUBO, HCR	0.6
• Variant: KTOE, TMEK, M1013, FCRXID, FCRXEK, SCR35, ASSISTA, GoFa	2.0
• Variant: CR15	-
Max. Workpiece weight [kg] in force-fit gripping ***	0.7

Size 64

Designation	Value			
	Co-act EGP-C 40			
Gripping force [%]	100	75	50	25
Current input in blocked state [A] ****	0.20	0.15	0.10	0.05

Designation	Value			
	Co-act EGP-C 64			
Supply voltage [VDC]	24			
Min. [VDC]	21.6			
Max. [VDC]	26.4			
Min. Supply current power supply unit [A] *				
• Variant: FCR7, UREK, KTOE	1.0			
• Variant: FCRXID, FCRXEK, TMEK, CR15, M1013	1.0			
• Variant: URID	2.0			
• Variant: TMID, AUBO, HCR, SCR35	-			
Max. Current input [A]**				
• Variant: FCR7, UREK, KTOE	2.0			
• Variant: URID, FCRXID, FCRXEK, TMEK, CR15, M1013, GoFa	2.0			
• Variant: TMID, AUBO, HCR, SCR35	-			
Max. Workpiece weight [kg] in force-fit gripping ***	1.15			
Gripping force [%] [A] ***	100	75	50	25
Current input in blocked state [A] ****	0.15	0.1	0.08	0.04

* minimum supply current for reliable operation of product

** maximum current input in the acceleration phase (max. t = 50 ms)

*** Higher values can be achieved in positive locking, depending on the maximum moment load (see catalog data sheet). The maximum workable workpiece weight shall be determined as part of a risk assessment by the integrator / operator, ▶ 2.3 [10].

**** Current input in blocked state (in gripper end position or while gripping a workpiece) with active command "Open Gripper" or "Close Gripper"

More technical data is included in the catalog data sheet.
Whichever is the latest version.

3.4 Ambient conditions and operating conditions

Designation	Co-act EGP-C
IP protection class (mechanical)	30
IP protection class (electrical)	40
Noise emission [dB(A)]	≤ 70
Ambient temperature [°C]	
Min.	5
Max.	55
Relative air humidity [%]	
Max.	95

4 Design and description

4.1 Design

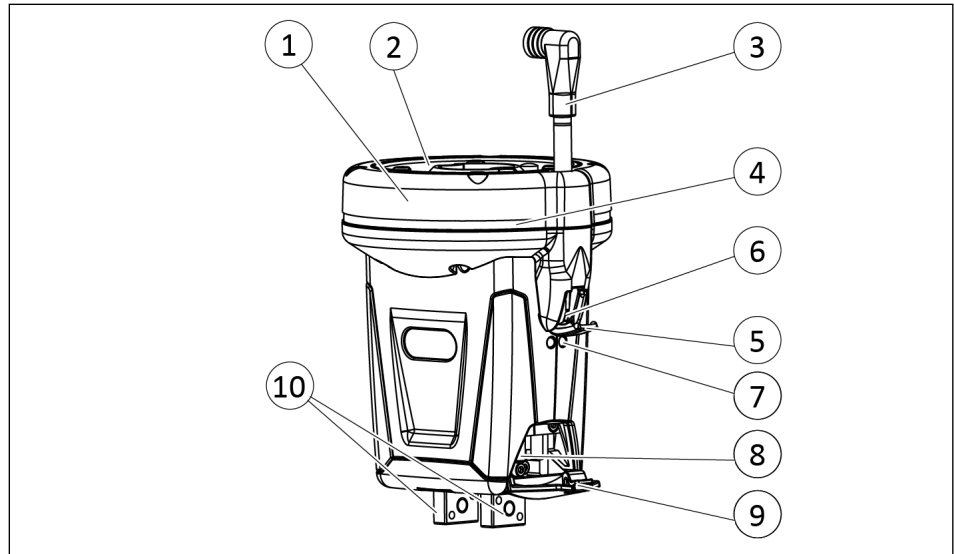

Design Co-act EGP-C

1	Collision protection cover
2	Flange for connecting the robot
3	Connector for voltage supply and actuation of the product (design depends on robot type)
4	LED strip light
5	Service flap
6	"Gripping force" rotary switch
7	LED
8	Sensors
9	Service flap
10	Base jaws

4.2 Description

The product is a servo-electric 2-finger parallel gripper featuring high power density for collaborative operation with

- integrated electronics,
- collision protection cover,
- integrated sensor system and
- adapter flange for robots.

4.3 Display

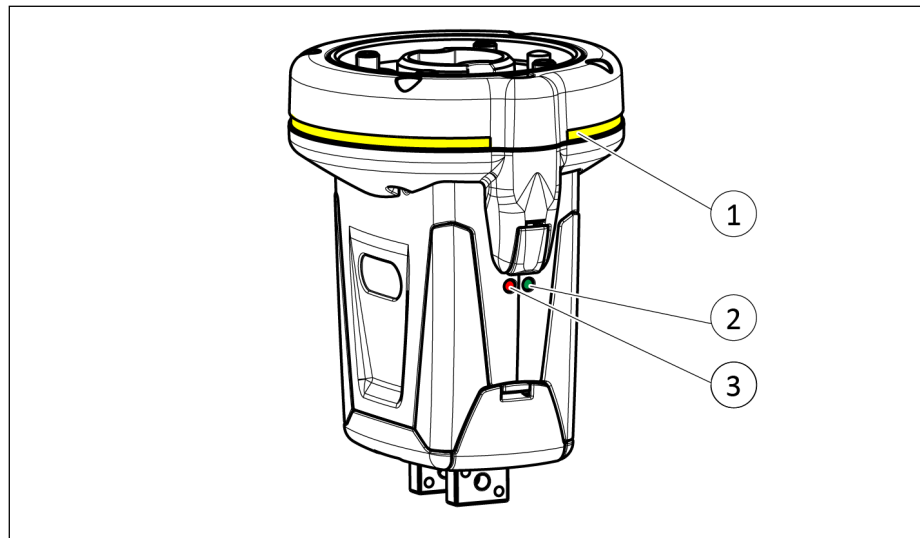

Status displays

1 *	LED light band	freely-configurable, application-specific display, ► 5.3.2 [45]
2	LED READY	Status display of the product
3	LED ERROR	

* only for variants FCR7, FCRXEK, UREK, TMEK, HCR, KTOE, KMFE

Designation	Color	Function
READY	Green	<p>Indicates whether the voltage is connected.</p> <ul style="list-style-type: none"> • Lights up as long as voltage is present in the product. • Does not light up if there is no voltage in the product.
ERROR	Red	<p>Indicates whether there is a warning or an error.</p> <ul style="list-style-type: none"> • Does not light up when there is no warning or error and the product is ready to operate. • Lights up when there is an "excessive temperature" warning. <ul style="list-style-type: none"> – The phase current of the motor is limited to I_{duration}. – The closing and opening times can increase. – Is automatically extinguished when the warning no longer exists. • Blinks slowly (at approx. 1.2 s intervals) when there is an "excessive temperature" error. <ul style="list-style-type: none"> – The product enters an idle phase until it has cooled down. The commands <i>Open gripper</i> and <i>Close gripper</i> are not processed. – The error must be acknowledged. • Blinks rapidly (at approx. 0.6 s intervals), when the Gripping force rotary switch is between two switching positions.

5 Assembly and settings

5.1 Installing and connecting

Overview

1. Check the evenness of the mounting surface, ▶ 5.2 [28].
2. Attach the product to the robot, ▶ 5.2 [28].
 - ⇒ Observe the tightening torque for the mounting screws.
3. Secure the gripper fingers to the base jaws, ▶ 5.2.1 [33].
4. Optional, based on design: Connect the cable for power supply and actuation, ▶ 5.3 [34].
5. Adjust the sensor, if necessary, ▶ 5.5 [47].
6. Adjust gripping force, if necessary, ▶ 5.4 [46].

5.2 Mechanical connection

Evenness of the mounting surface

The values apply to the whole mounting surface to which the product is mounted.

Edge length	Permissible unevenness
< 100	< 0.02
> 100	< 0.05

Tab.: Requirements for evenness of the mounting surface (Dimensions in mm)

Electrically conductive

The mounting surface must be electrically conductive to ensure the grounding of the product.

The previous section contains the requirements from SAC-11-P, ▶ 2.3 [11]

Connections at the product

The product has an ISO flange that makes it possible to fasten it to the robot. The dimensions of the ISO flange vary depending on the product variant and depending on the robot type.

NOTE

The product's ID number is located on the name plate. The catalog data sheet contains the assignment of the ID number of the listed product variants.

Connection version	Product variant, ▶ 3.2 [22]
ISO flange 31.5	Co-act EGP-C FCR7 Co-act EGP-C ASSISTA
ISO flange 50	Co-act EGP-C KMFE Co-act EGP-C KTOE Co-act EGP-C URID Co-act EGP-C UREK Co-act EGP-C TMID Co-act EGP-C TMEK Co-act EGP-C CR15 Co-act EGP-C AUB0 Co-act EGP-C SCR35 Co-act EGP-C HCR Co-act EGP-C M1013 Co-act EGP-C FCRXID Co-act EGP-C FCRXEK Co-act EGP-C GoFa

Connection variant: ISO flange 31.5

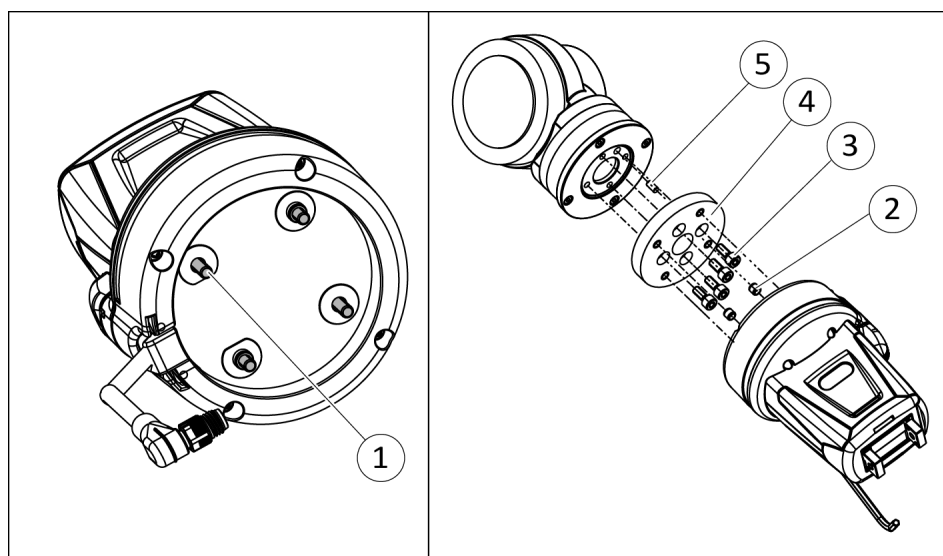

Installation of the product on the robot with ISO flange, bolt pitch circle \varnothing 31.5

Item	Mounting	Co-act EGP-C
1	Mounting screw	M4 x 18
2 *	Centering sleeve [mm]	∅ 6
3 *	Mounting screw	M5 x 10
	Tightening torque [Nm]	6.1
4 *	ISO-Flange	ISO 9409-1-31.5-4-M5
5 *	Centering pin [mm]	∅ 5

* Contained in accessory pack.

1. Insert centering pin (5) into the ISO flange (4).
2. Set the ISO flange (4) on the robot and fasten using screws (3).
⇒ Observe the tightening torque.
3. Insert centering sleeves (2) into the counterbores on the product flange.
4. **For variants with connection cables:** Align the product on the robot flange so that the cables are long enough for connection to the robot control system.
5. Fasten the product on the ISO flange (4) using screws (1) and the ball-head hexagon socket wrench supplied.

Note: The mounting screws (1) are already pre-assembled on the product. A ball-head Allen key required for installation with a working angle of 30° is included in the accessory pack.

Connection variant: ISO flange 50

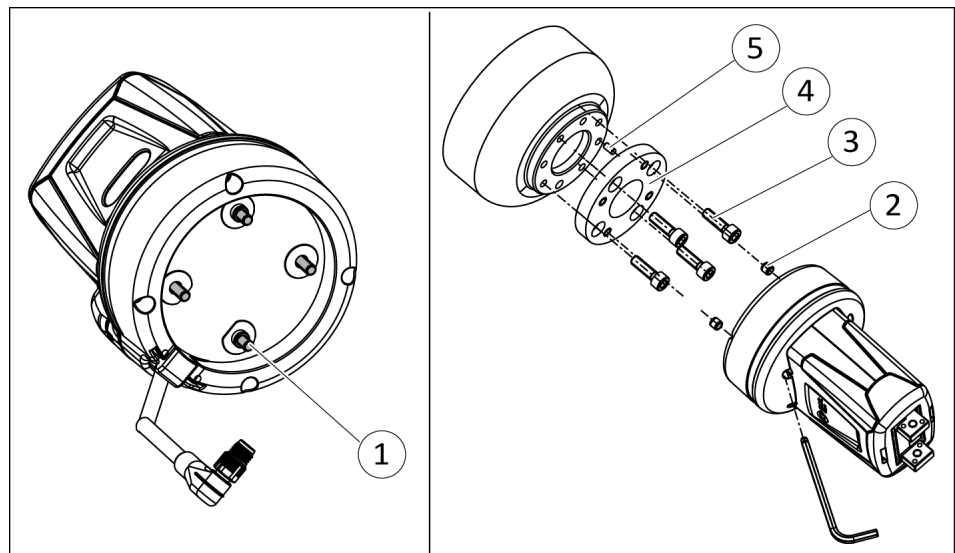

Installation of the product on the robot with ISO flange, bolt pitch circle ∅ 50

Item	Mounting	Co-act EGP-C
1	Mounting screw	M4 x 18
2 *	Centering sleeve [mm]	∅ 6
3 *	Mounting screw	M6 x 10

Item Mounting		Co-act EGP-C	
	Tightening torque [Nm]	10	
4 *	ISO-Flange	ISO 9409-1-50-4-M6	
5 *	Centering pin [mm]	Ø 6	

* Contained in accessory pack.

1. Insert centering pin (5) into the ISO flange (4).
2. Set the ISO flange (4) on the robot and fasten using screws (3).
⇒ Observe the tightening torque.
3. Insert centering sleeves (2) into the counterbores on the product flange.
4. **For variants with connection cables:** Align the product on the robot flange so that the cables are long enough for connection to the robot control system.
5. Fasten the product on the ISO flange (4) using screws (1) and the ball-head hexagon socket wrench supplied.

Note: The mounting screws (1) are already pre-assembled on the product. A ball-head Allen key required for installation with a working angle of 30° is included in the accessory pack.

Connections at the base jaws

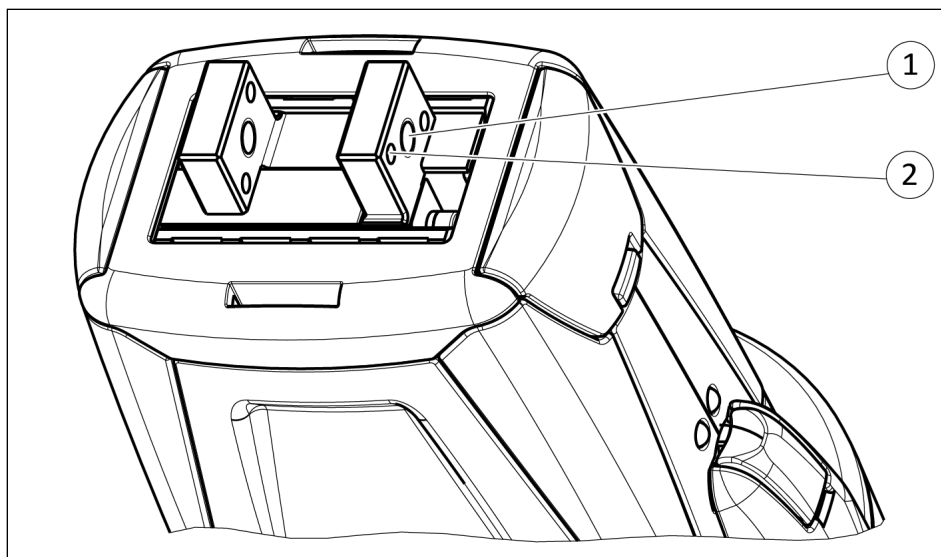

Connections at the base jaws

Item	Designation	Co-act EGP-C	
		40	64
1	Thread in base jaws	M5	M8
	Max. depth of engagement from locating surface [mm]	6	10
	Max. tightening torque of the mounting screws [Nm]		
	– Steel gripper fingers:	6.1	25

Item	Designation	Co-act EGP-C	
		40	64
	– Plastic gripper fingers:	4.3	5
2	Bore holes for cylindrical pin [mm]	Ø 2.5	Ø 4

Tab.: Screw-in depth and tightening torque

Further information on installation, ▶ 5.2.1 [33].

5.2.1 Install gripper fingers

NOTE

Gripper fingers are available as accessories from SCHUNK, see the catalog data sheet for further information.

Variant: Rigid gripper finger

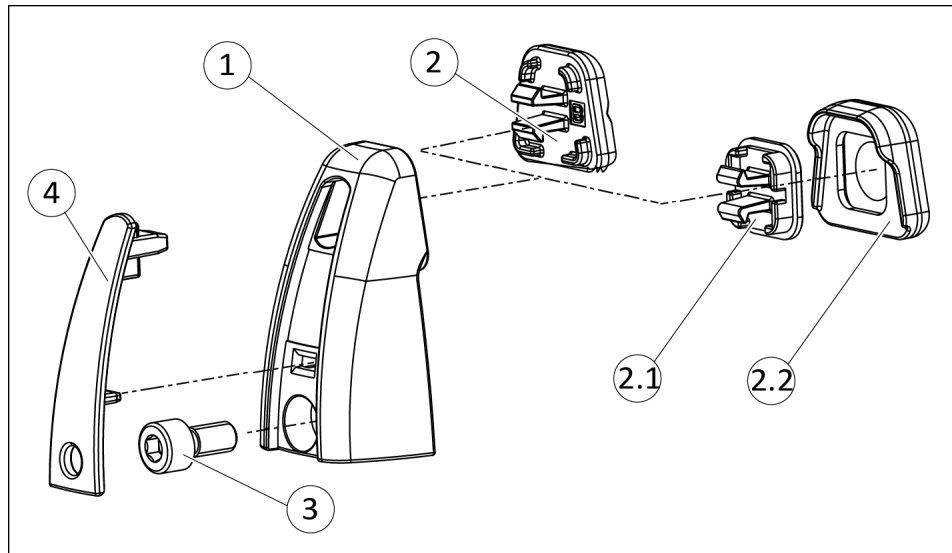

1. Fasten gripper finger (1) to the base jaw using the screw (3).
 - ⇒ Observe the permissible depth of engagement.
 - ⇒ Observe the tightening torque for the mounting screws.
 - ⇒ Information on the tightening torque and depth of engagement, ▶ 5.2 [31].
2. Clip the inlay (2) to the gripper finger (1).
OR: clip inlay (2.1) to the gripper finger (1) and attach silicone cover (2.2).
3. Clip the cover (4) to the gripper finger (1).

5.3 Electrical connection

5.3.1 Connection assignment

Based on product variant – depending on the robot type – the product has one of the following connections.

NOTE

The product's ID number is located on the name plate. The catalog data sheet contains the assignment of the ID number of the listed product variants.

No.	Connection version	Product variant, ▶ 3.2 [📄 22]
1	M8 socket, 8-pin	Co-act EGP-C URID Co-act EGP-C AUB0 Co-act EGP-C SCR35 Co-act EGP-C FCRXID
2	M12 connector, 17-pin	Co-act EGP-C KTOE
3	Cable with wire strands	Co-act EGP-C UREK Co-act EGP-C FCR7 Co-act EGP-C TMEK Co-act EGP-C CR15 Co-act EGP-C FCRXEK Co-act EGP-C 64-M1013
5	M8 connector, 8-pin and M8 connector, 3-pin	Co-act EGP-C KMFE
6	M8 connector, 8-pin	Co-act EGP-C TMID Co-act EGP-C 40-M1013
7	M12 connector, 12-pin	Co-act EGP-C HCR
8	M12 connector, 8-pin	Co-act EGP-C ASSISTA
10	M8 connector, 3-pin and M8 connector, 4-pin	Co-act EGP-C GoFa

Connection version 1: M8 socket, 8-pin

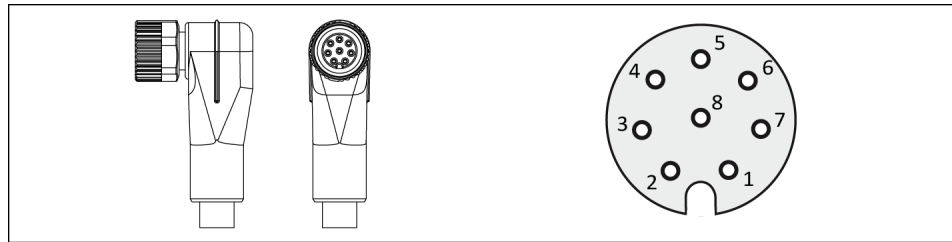

M8 socket, 8-pin

Co-act EGP-C URID

Pin	Wire strand	Signal	Robot interface	
			CB-series connector	e-series connector
1	White	n.c.	AI 2	AI 2/RS485+
2	Brown	n.c.	AI 3	AI 3/RS485-
3	Green	Sensor 2	DI 9	DI 1
4	Yellow	Sensor 1	DI 8	DI 0
5	Grey	+24 VDC	12/24 V	12/24 V
6	Pink	Closes gripper	DO 9	DO 1
7	Blue	Opens gripper	DO 8	DO 0
8	Red	GND	GND	GND

Tab.: Connection assignment Co-act EGP-C URID

Co-act EGP-C AUBO

Pin	Wire strand	Signal	Robot interface
1	White	GND	GND
2	Brown	+24 VDC	24 V
3	Green	Sensor 2	DI/DO 2
4	Yellow	Sensor 1	DI/DO 3
5	Grey	Closes gripper	DI/DO 0
6	Pink	n.c.	AI 1
7	Blue	Opens gripper	DI/DO 1
8	Red	n.c.	AI 0

Tab.: Connection assignment Co-act EGP-C AUBO

Co-act EGP-C SCR35

Pin	Wire strand	Signal	Robot interface
1	White	n.c.	n.c.
2	Brown	n.c.	n.c.
3	Green	Sensor 2	Digital input DI 2
4	Yellow	Sensor 1	Digital input DI 1
5	Grey	+24 VDC	24 V
6	Pink	Closes gripper	Digital output DO 2
7	Blue	Opens gripper	Digital output DO 1
8	Red	GND	GND

Tab.: Connection assignment Co-act EGP-C SCR35

Co-act EGP-C FCRXID

Pin	Wire strand	Signal	Robot interface
1	White	n.c.	RS485+
2	Brown	n.c.	RS485-
3	Green	Sensor 2	Digital input DI 2
4	Yellow	Sensor 1	Digital input DI 1
5	Grey	+24 VDC	24 V
6	Pink	Closes gripper	Digital output DO 2
7	Blue	Opens gripper	Digital output DO 1
8	Red	GND	0V

Tab.: Connection assignment Co-act EGP-C FCRXID

Connection version 2: M12 connector, 17-pin

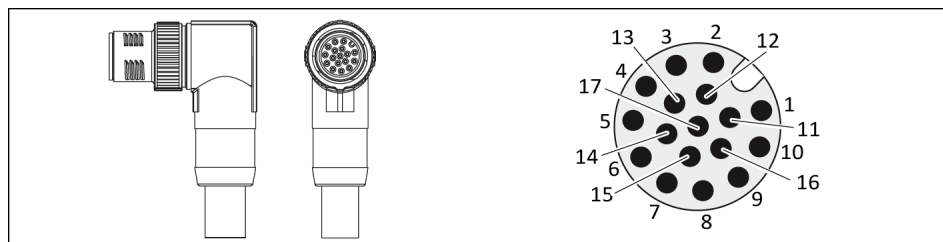

M12 connector, 17-pin

Co-act EGP-C KTOE

Pin	Wire strand	Signal	KUKA connection X3
1	Brown	Closes gripper	MF_Output_0
2	Blue	Digital input DI 2 (LED strip light)	MF_Output_3
3	White	Sensor 4 (optional)	MF_Input_3
4	Green	n.c.	MF_Input_4
5	Pink	GND	GND_24V
6	Yellow	n.c.	GND_24V
7	Black	+24 VDC	Output_VCC
8	Grey	n.c.	Output_VCC
9	Red	n.c.	Output_VCC
10	Violet	Sensor 1	MF_Input_0
11	Grey/Pink	Opens gripper	MF_Output_1
12	Red/Blue	Digital input DI 1 (LED strip light)	MF_Output_2
13	White/Green	Sensor 3 (optional)	MF_Input_2
14	Brown/Green	n.c.	GND_24V
15	White/Yellow	n.c.	Output_VCC
16	Yellow/Brown	Sensor 2	MF_Input_3
17	White/Grey	n.c.	GND_24V

Tab.: Connection assignment Co-act EGP-C KTOE

Connection version 3: cable with wire strands

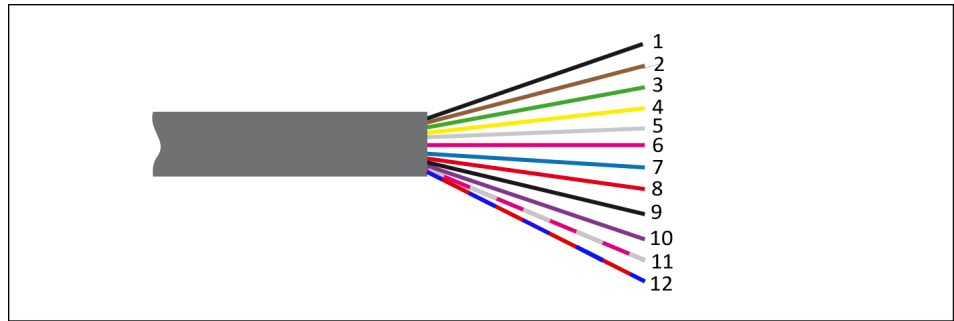

Cable with 12 wire strands

**Co-act EGP-C UREK,
FCR7, FCRXEK, TMEK,
CR15, 64-M1013**

No.	Wire strand	Signal
1	White	Digital input DI 2
2	Brown	Digital input DI 1
3	Green	Sensor 2
4	Yellow	Sensor 1
5	Grey	Sensor 4 (optional, on request)
6	Pink	Sensor 3 (optional, on request)
7	Blue	Closes gripper
8	Red	Opens gripper
9	Black	n.c.
10	Violet	n.c.
11	Grey/Pink	GND
12	Red/Blue	+24 VDC

Tab.: Connection assignment Co-act EGP-C UREK, FCR7, FCRXEK, TMEK, CR15

Connection version 5: M8 connector, 8-pin and M8 connector, 3-pin

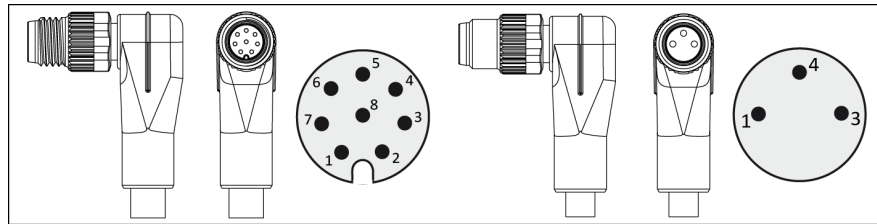

M8 connector, 8-pin and M8 connector, 3-pin

Co-act EGP-C KMFE

Pin	Wire strand	Signal
M8 connector, 8-pin		
1	White	Closes gripper
2	Brown	Opens gripper
3	Green	Digital input DI 1
4	Yellow	Sensor 1
5	Grey	Sensor 2
6	Pink	Digital input DI 2
7	Blue	Sensor 3 (optional)
8	Red	Sensor 4 (optional)
M8 connector, 3-pin		
1	Brown	+24 VDC
3	Blue	GND
4	Black	n.c.

Tab.: Connection assignment Co-act EGP-C KMFE

Connection version 6: M8 connector, 8-pin

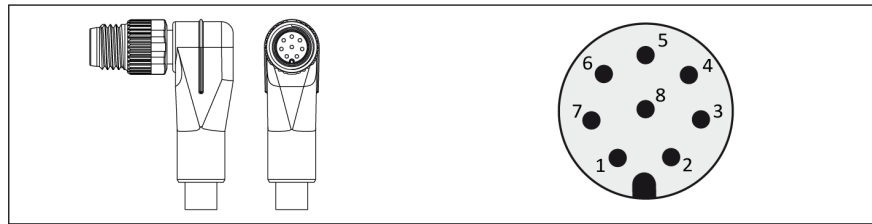

M8 connector, 8-pin

Co-act EGP-C TMID

Pin	Wire strand	Signal	Robot interface
1	White	+24 VDC	+24 V
2	Brown	Sensor 1	Digital input DI 0
3	Green	Sensor 2	Digital input DI 1
4	Yellow	n.c.	Digital input DI 2
5	Grey	Opens gripper	Digital output DO 0
6	Pink	Closes gripper	Digital output DO 1
7	Blue	n.c.	Digital output DO 2
8	Red	GND	GND

Tab.: Connection assignment Co-act EGP-C TMID

**Co-act EGP-C
40-M1013**

Pin	Wire strand	Signal	Robot interface Series M, H, A
1	White	Sensor 1	Digital input DI 1
2	Brown	Closes gripper	Digital output DO 1
3	Green	Opens gripper	Digital output DO 2
4	Yellow	n.c.	RS485 A (series A)
5	Grey	+24 VDC	+24 VDC
6	Pink	n.c.	RS485 B (series A)
7	Blue	Sensor 2	Digital input DI 2
8	Red	GND	GND

Tab.: Connection assignment Co-act EGP-C M1013

Connection version 7: M12 connector, 12-pin

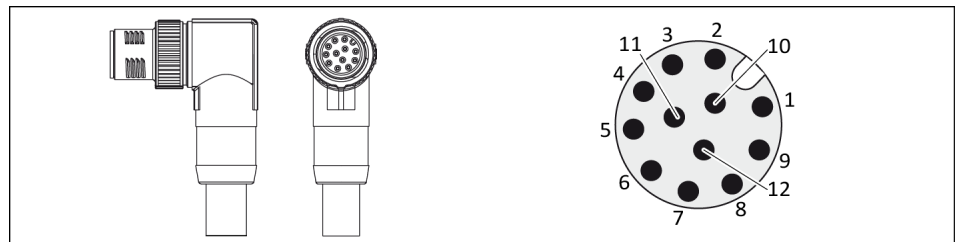

M12 connector, 12-pin

Co-act EGP-C HCR

Pin	Signal	Robot interface
1	+24 VDC	0/12/24 VDC
2	GND	GND
3	Closes gripper	Digital output D0 0
4	Opens gripper	Digital output D0 1
5	Digital input 2	Digital output D0 2
6	Digital input 1	Digital output D0 3
7	Sensor 1	Digital input DI 0
8	Sensor 2	Digital input DI 1
9	n.c.	Digital input DI 2
10	n.c.	Digital input DI 3
11	n.c.	Analog input AI 0
12	n.c.	Analog input AI 1

Tab.: Connection assignment Co-act EGP-C HCR

Connection version 8: M12 connector, 8-pin

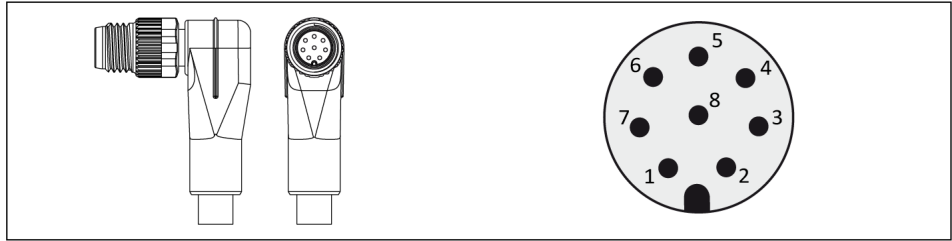

M12 connector, 8-pin

Co-act EGP-C ASISSTA

Pin	Wire strand	Signal	Robot interface
1	White	GND	RG
2	Brown	+ 24 V	+24VDC
3	Green	Opens gripper	GR1
4	Yellow	Closes gripper	GR2
5	Grey	DI1 (RGB_LED)	GR3
6	Pink	DI2 (RGB_LED)	GR4
7	Blue	Sensor 1	HC2
8	Red	Sensor 2	HC1

Tab.: Connection assignment Co-act EGP-C ASISSTA

Connection version 10: M8 connector, 4-pin and M8 connector, 3-pin

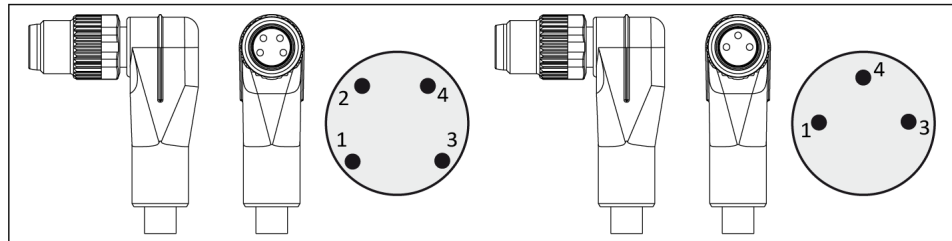

M8 connector, 4-pin and M8 connector, 3-pin

Co-act EGP-C GoFa

Signal	Connection Co-act EGP-C on the robot flange		Connection Co-act EGP-C on the OmniCore control unit *		
	Pin	Wire strand	Pin X2	Wire strand	Terminal > Signal
	M8 connector, 3-pin		M12 cable, 8-pin		
+24 VDC	1	Brown	7	Blue	X19 > +24 VDC
GND	3	Blue	8	Red	X19 > GND
n.c.	4	Black	n.c.	n.c.	n.c.
	M8 connector, 4-pin				
Opens gripper	1	Brown	1	White	I/O > DO
Closes gripper	2	White	2	Brown	I/O > DO
Sensor 1	3	Blue	3	Green	I/O > DI
Sensor 2	4	Black	4	Yellow	I/O > DI

Tab.: Connection assignment Co-act EGP-C GoFa

* Both flange connectors of the product are internally wired to the control unit with an 8-pin M12 connector (X2). An 8-pin M12 cable is used to connect the terminals of the control unit.

Connect the connections of the OmniCore control unit as follows:

1. From X19, connect a pair of wires 24V and GND to the upper two terminals (PW DO and GND DO) of the DO section of the DSQC1030 board.
2. From X19, connect a single wire to terminal GND DI of the DI section of the DSQC1030 board.
3. Connect M12 cable, 8-pin with open wire strands (included in scope of delivery) to connector X2 and connect wire strands to terminals X19 and I/O of the OmniCore control unit.

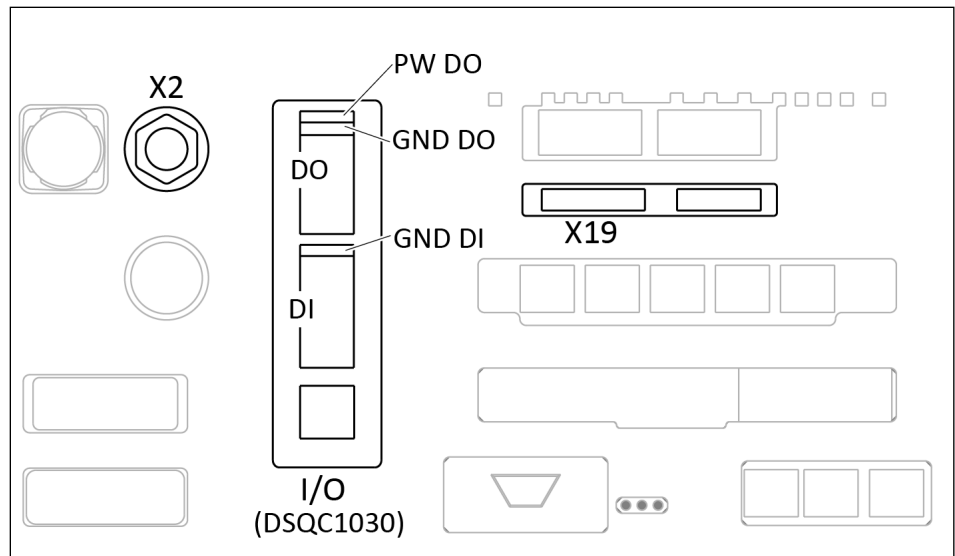

OmniCore control unit

5.3.2 Actuation

Truth table

The following truth tables show the actuation of the digital inputs during possible commands by the superordinated control unit.

Current input per digital input amounts to max. I=10 mA.

Depending on the connection variant, the digital inputs are used differently, ▶ 5.3.1 [34].

NOTE

- **Size 40** : For the variants URID and TMID, digital inputs are executed in switching mode "NPN".
- **Size 64**: For the variant URID, digital inputs are executed in switching mode "PNP".

Actuation Opens gripper / Closes gripper

Function	Digital input	
	Opens gripper	Closes gripper
De-energized drive (shutdown, motor is short-circuited)	0	0
Opens gripper	1	0
Closes gripper	0	1
Rectify error (shutdown, motor is short-circuited)	1	1

Rest period between two commands

NOTICE

Material damage due to faulty control!

The internal electronics can be damaged by two commands following too quickly in succession.

- Maintain a rest period between commands.

The following graph shows the minimum rest period that must be kept between two commands.

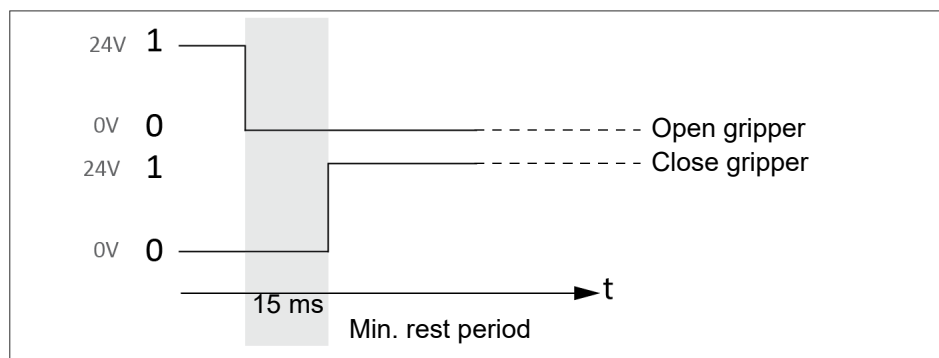

Example Opens gripper / Closes gripper

Actuation LED light band

Function	Digital input	
	DI 2	DI 1
LED light band is not lighting up	0	0
LED light band shines green	1	0
LED light band shines yellow	0	1
LED light band shines red	1	1

NOTE

The brightness values of the LED colors were preconfigured in the factory.

5.4 Adjust gripping force

The gripping force is changed by altering the current limitation via the "Gripping force" rotary switch.

In order to change the gripping force, inputs "Opens gripper" and "Closes gripper" must be de-energized (low), ▶ 5.3.2 [45].

5.4.1 Size 40 and 64

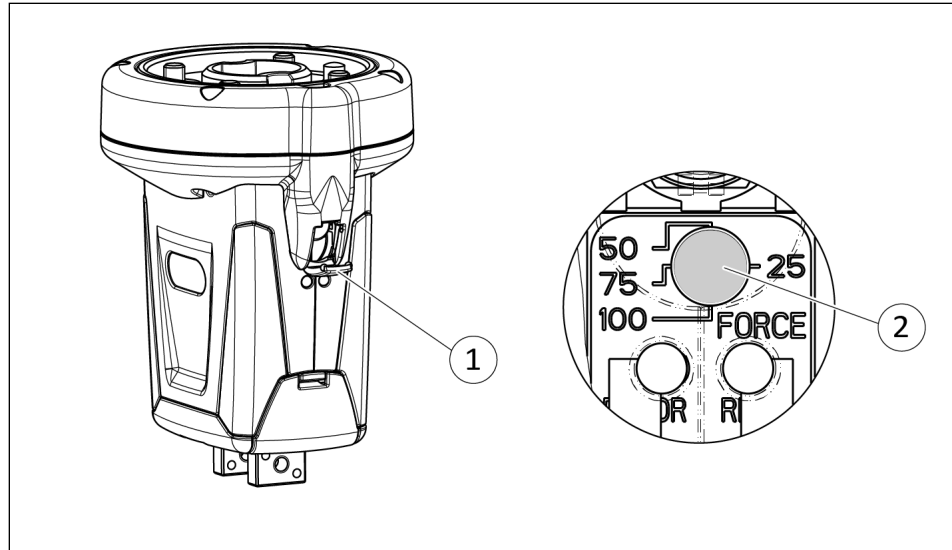

Access to "Gripping force" rotary switch

■ Digital inputs "Opens gripper" and "Closes gripper" are not powered (low), ▶ 5.3.2 [45].

1. Open service flap (1).
2. Remove seal plug (2).
3. Adjust gripping force on the "Gripping force" rotary switch. Do this using a suitable slot screwdriver with a blade at least 2 mm wide. **NOTICE! Do not exert axial pressure on the axis of the rotary switch.**

Note: The "Gripping force" rotary switch has four set positions.

4. Insert seal plug (2).
5. Close service flap (1).

Item	Gripping force [%]
100 (standard)	100
75	75
50	50
25	25

5.5 Adjust the sensors

In the delivery state the sensors come mounted on the product, the positions "open" and "closed" are configured.

Sensors only need to be adjusted if the position "Part gripped" is to be monitored.

5.5.1 Size 40

NOTE

To monitor the position "Part gripped", a spacer sleeve must be installed. The spacer sleeve and the required longer screw are included in the accessory pack.

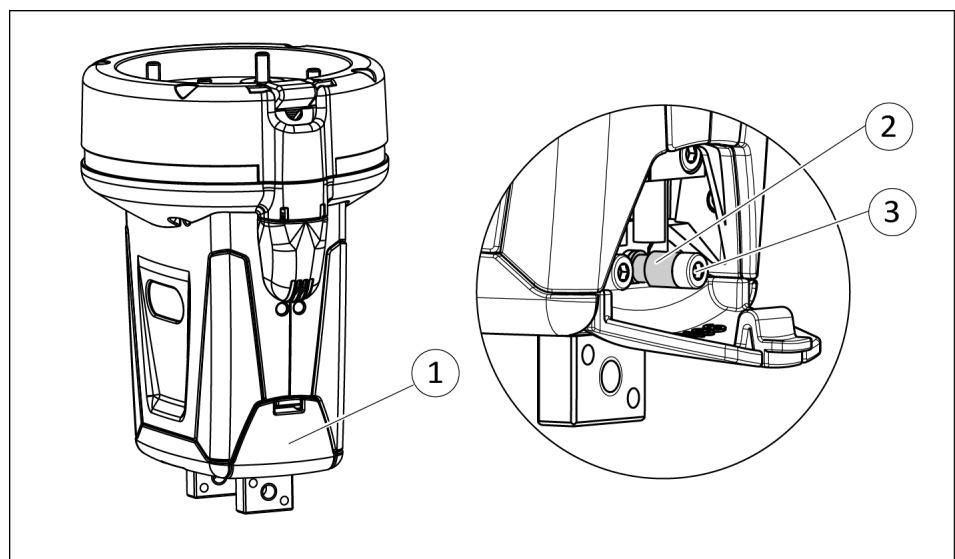

Adjust the sensor

1. Open service flap (1).
2. Unscrew screws (3).
3. Secure spacer sleeve (2) to the base jaw with the screw from the accessory pack.
Tightening torque: 12.5 Ncm
4. Put product in the position in which it is to be set.
5. Monitor the "Part gripped" position and test the function.
6. Close service flap (1).

6 Start-up

Carrying out the commissioning, the risk assessment and the documentation of the safety verification for integration must be carried out upon every modification of the customer-specific application (e.g. when gripping other workpieces).

If existing settings unchanged, e.g. grip width and workpiece weight, this risk potential can be substantiated as non-critical by performing the risk assessment again. The information/queries in the check-list (▶ 14.1 [📄 57]) must be taken into account in the risk assessment.

In order to facilitate the integration of the product in a machine, a gantry or a robot system, it is possible to use the checklist (▶ 14.1 [📄 57]) to check and document the main points of integration.

NOTE

The checklist does not lead to full compliance with the legal requirements applicable to the end effector, ▶ 14.1 [📄 57].

7 Troubleshooting

7.1 Product does not move

Possible cause	Corrective action
Base jaws jam in housing, e.g. mounting surface is not sufficiently even.	Check the evenness of the mounting surface. ▶ 5.2 [28]
	Loosen the mounting screws of the product and actuate the product again.
Sensor incorrectly set. / Sensor is misaligned.	Adjust sensor so that it does not obstruct the traverse path of the product. Distance to the querying mechanics: approx.0.2 mm
Power supply connected incorrectly.	Check the power supply. ▶ 5.3 [34]
Internal fuse has triggered.	Send the product to SCHUNK with a repair order.

7.2 Product does not execute a complete stroke

Possible cause	Corrective action
Mounting surface is not sufficiently flat.	Check the evenness of the mounting surface. ▶ 5.2 [28]
Breakage of components, e.g. by overloading.	Send the product to SCHUNK with a repair order.

7.3 Product opens or closes jerkily

Possible cause	Corrective action
Mounting surface is not sufficiently flat.	Check the evenness of the mounting surface. ▶ 5.2 [28]
Loading too large.	Check permissible weight and length of the gripper fingers. ▶ 3 [21]

7.4 Gripping force too low

Possible cause	Corrective action
Wrong gripping pre-selection.	Check rotary switch setting. ▶ 5.3 [34]
	Check layout of the product. Meanwhile observe the maximum workpiece weight, see Catalog Data Sheet. ▶ 3 [21]

7.5 Opening and closing times are not achieved

Possible cause	Corrective action
Loading too large.	Check permissible weight and length of the gripper fingers.

7.6 Electric signals are not transmitted?

Possible cause	Corrective action
Cable connected incorrectly.	Check that the plug is connected properly. ▶ 5.3 [📄 34]
Strands swapped.	Check pin allocation. ▶ 5.3 [📄 34]

7.7 Faults which are displayed via LED Error

Possible cause	LED "Error"	Corrective action
Rotary switch is in an intermediate position	LED blinks at 0.6 s intervals	Turn rotary switch to a marked position.
Error overheating	LED blinks at 1.2 s intervals	Let product cool down and acknowledge error. ▶ 7.8 [📄 50]
Warning overheating	LED glows continuously	The warning is automatically deleted when the product has cooled down.

7.8 Acknowledge error

1. Wait until the product has cooled down.
 2. Actuate both digital inlets, "Opens gripper" and "Closes gripper", with high.
OR:
Disconnect voltage supply and reconnect.
- ⇒ The "ERROR" LED goes out. The error is acknowledged.

8 Maintenance

This product must not be disassembled for maintenance.

Maintenance interval	Maintenance work
1000 cycles or once per day	Travel an entire stroke. Check the gripper fingers for correct positioning or damage.
2 million cycles	Inspect the product for damage. Send damaged products to SCHUNK for repair.
as required	Wipe the product with a damp cloth. NOTICE! Do not use any scouring, abrasive cleaning agents or chemical solvents.

NOTICE

Damage to property caused by insufficient lubrication!

Continuously traveling short strokes when the product is inadequately lubricated risks damaging it by causing it to run dry.

- Travel the full stroke every 1000 cycles or at least once daily.

NOTICE

Material damage due to improper disassembly!

Incorrect works can cause damage to the mechanics and internal electronics.

- Disassembly or opening of the product is not permitted.
- Only allow SCHUNK to repair the product.

9 EU-Declaration of Conformity

Manufacturer/ Distributor	SCHUNK SE & Co. KG Spanntechnik Greiftechnik Automatisierungstechnik Bahnhofstr. 106 – 134 D-74348 Lauffen/Neckar
Product designation:	Electrical small components gripper for collaborative operations / Co-act EGP-C /electric
ID number	1321172, 1326455, 1326456, 1326469, 1327883, 1327885, 1359018, 1374363, 1375931, 1400578, 1408586, 1416679, 1436401, 1441947, 1441948, 1441949, 1441950, 1468548, 1468551

We hereby declare on our sole authority that the product meets the requirements of the following directives at the time of the declaration.

The declaration is rendered invalid if modifications are made to the product.

- **EMC Directive 2014/30/EU**

Directive of the European Parliament and the Council of February 26, 2014 on the harmonization of the laws of the Member States relating to electromagnetic compatibility

Applied harmonized standards, especially:

EN IEC 61000-6-2:2019	Electromagnetic compatibility (EMC) – Part 6-2: Generic standards – Immunity standard for industrial environments
EN IEC 61000-6-4:2019	Electromagnetic compatibility (EMC) – Part 6-4: Generic standards – Emission standard for industrial environments

Signed for and on behalf of: SCHUNK SE & Co. KG

Signature: see original declaration

Dr.-Ing. Manuel Baumeister,
Head of Systems Engineering,
Technology & Innovation

Lauffen/Neckar, September 2025

10 UKCA declaration of Conformity

Manufacturer/
Distributor SCHUNK Intec Limited
 Clamping and gripping technology
 3 Drakes Mews, Crownhill
 MK8 0ER Milton Keynes

We hereby declare on our sole authority that the product meets the requirements of the following directives at the time of the declaration.

The declaration is rendered invalid if modifications are made to the product.

Product designation: Electrical small components gripper for collaborative operations
 Co-act EGP-C

ID number 1321172, 1326455, 1326456, 1326469, 1327883, 1327885, 1359018,
 1374363, 1375931, 1400578, 1408586, 1416679, 1436401, 1441947,
 1441948, 1441949, 1441950, 1468548, 1468551

- **Electromagnetic Compatibility Regulations 2016**

Applied harmonized standards, especially:

EN IEC 61000-6-2:2019 Electromagnetic compatibility (EMC) – Part 6-2:
 Generic standards – Immunity standard for industrial environments

EN IEC 61000-6-4:2019 Electromagnetic compatibility (EMC) – Part 6-4:
 Generic standards – Emission standard for industrial environments

Person authorized to compile the technical documentation:

Marcel Machado, address: refer to manufacturer's address

Signed for and on behalf of: SCHUNK SE & Co. KG



Dr.-Ing. Manuel Baumeister, Head of
Systems Engineering, Technology &
Innovation

Lauffen/Neckar, September 2025

11 Translation of the original declaration of incorporation

in terms of the Directive 2006/42/EG, Annex II, Part 1 Section B.

Manufacturer/ Distributor SCHUNK SE & Co. KG
Spanntechnik | Greiftechnik | Automatisierungstechnik
Bahnhofstr. 106 – 134
D-74348 Lauffen/Neckar

We hereby declare that the partly completed machine described below

Product designation: Electrical small components gripper for collaborative operations /
Co-act EGP-C /electric

ID number 1321172, 1326455, 1326456, 1326469, 1327883, 1327885, 1359018,
1374363, 1375931, 1400578, 1408586, 1416679, 1436401, 1441947,
1441948, 1441949, 1441950, 1468548, 1468551

meets the following basic occupational health and safety of the Machinery Directive 2006/42/EC:
No. 1.1.1, No. 1.1.2, No. 1.1.3, No. 1.1.5, No. 1.3.2, No. 1.5.1, No. 1.5.2; No. 1.5.4, No. 1.5.6, No.
1.5.8, No. 1.5.10, No. 1.5.11, No. 1.5.13

The partly completed machinery may not be put into operation until it has been confirmed that the machine into which the partly completed machinery is to be installed complies with the provisions of the Machinery Directive (2006/42/EC). The declaration shall be rendered invalid if modifications are made to the product.

Applied harmonized standards, especially:

EN ISO 12100:2010 Safety of machinery – General principles for design –
Risk assessment and risk reduction

EN ISO 10218-1:2011 Robots and robotic devices – Safety requirements – Part 1: Robots

EN ISO 10218-2:2011 Robots and robotic devices – Safety requirements – Part 2: Robot
systems and integration

Applied technical specification:

ISO /TS 15066:2016 Robots and robotic devices – Collaborative robots / Power and force
limiting applications

The special technical documentation according to Annex VII, Part B, belonging to the partly completed machine, has been created.

Person authorized to compile the technical documentation:
Stefanie Walter, Address: see manufacturer's address

Signature: see original declaration

Dr.-Ing. Manuel Baumeister, Head of
Systems Engineering, Technology &
Innovation

Lauffen/Neckar, September 2025

12 UKCA declaration of incorporation

in accordance with the Supply of Machinery (Safety) Regulations 2008.

Manufacturer/
Distributor SCHUNK Intec Limited
 Clamping and gripping technology
 3 Drakes Mews, Crownhill
 MK8 0ER Milton Keynes

We hereby declare that on the date of the declaration the following partly completed machine complied with all basic safety and health regulations found in the "Supply of Machinery (Safety) Regulations 2008".

The declaration shall be rendered invalid if modifications are made to the product.

Product designation: Electrical small components gripper for collaborative operations /
 Co-act EGP-C / electric

ID number 1321172, 1326455, 1326456, 1326469, 1327883, 1327885, 1359018,
 1374363, 1375931, 1400578, 1408586, 1416679, 1436401, 1441947,
 1441948, 1441949, 1441950, 1468548, 1468551

The partly completed machine may not be put into operation until it has been confirmed that the machine into which the partly completed machine is to be installed complies with the provisions of the "Supply of Machinery (Safety) Regulations 2008".

Applied harmonized standards, especially:

EN ISO 12100:2010	Safety of machinery – General principles for design – Risk assessment and risk reduction
EN ISO 10218–1:2011	Robots and robotic devices – Safety requirements – Part 1: Robots
EN ISO 10218–2:2011	Robots and robotic devices – Safety requirements – Part 2: Robot systems and integration

Applied technical specification:

ISO /TS 15066:2016	Robots and robotic devices – Collaborative robots / Power and force limiting applications
--------------------	--

The special technical documentation according to Annex VII, Part B, belonging to the partly completed machine, has been created.

Person authorized to compile the technical documentation:
Marcel Machado, address: refer to manufacturer's address



Dr.-Ing. Manuel Baumeister,
Head of Systems Engineering,
Technology & Innovation

Lauffen/Neckar, September 2025

13 Information on the RoHS Directive, REACH Regulation and Substances of Very High Concern (SVHC)

RoHS Directive

SCHUNK products are classified as "large-scale stationary installations" or as "large-scale stationary industrial tools" within the meaning of Directive 2011/65/EU and its extension 2015/863/EU "on the restriction of the use of certain hazardous substances in electrical and electronic equipment (RoHS)", or fulfill their intended function only as part of one. Therefore products from SCHUNK do not fall within the scope of the directive at this time.

REACH Regulation

Products from SCHUNK fully comply with the regulations of Regulation (EC) No. 1907/2006 "concerning the Registration, Evaluation, Authorization and Restriction of Chemicals (REACH)" and its amendment 2022/477. SCHUNK attaches great importance to completely avoiding chemicals of concern to humans and the environment wherever possible.

Only in rare exceptional cases do SCHUNK products contain SVHC substances on the candidate list with a mass content above 0.1%. In accordance with Article. 33 (1) of Regulation (EC) No. 1907/2006, SCHUNK complies with its duty to "communicate information on substances in articles" and lists the components concerned and the substances used in an overview that can be viewed at [schunk.com/SVHC](https://www.schunk.com/SVHC).

Signature: see original declaration

Dr.-Ing. Manuel Baumeister,
Head of Systems Engineering,
Technology & Innovation

Lauffen/Neckar, September 2025

14 Appendix

14.1 Commissioning checklist

NOTE

The integrator can use the following checklist to describe and take the commissioning settings into account.

The checklist does not lead to full compliance with the legal requirements applicable to the end effector, ▶ 6 [48].

relevant /
implemented

Identify product:

Check the settings for accuracy using the application-specific documents and document them.

Designation / ID no.: _____

Gripping type: I.D. gripping O.D. gripping

Gripping force adjustment [%]: _____

Installation position: suspended upright other:

Tool centre point (TCP): _____

Acceleration of the product [m/s^2]: +/- X: ____ +/- Y: ____ +/- Z: ____

Number of cycles per minute: _____

relevant /
implemented

Identify gripper fingers:

Get the required information from the application-specific documentation or measure/determine it directly and document it.

Finger height (top edge of gripper to contact point of workpiece) [mm]: _____

Projection [mm]: _____

Holding principle: force-fit gripping form-fit (Prisma)

Weight of a gripper finger [g]: _____

Gripper finger material: _____

Gripper finger shape: _____

Gripper finger surface: _____

Are the material, shape, and surface of the gripper fingers compliant with ISO/TS 15066?

Finger tips material: _____

Finger tips shape: _____

Finger tips surface: _____

Are the material, shape, and surface of the finger tips compliant with ISO/TS 15066?

relevant /
implemented**Identify workpiece:**

Get the required information from the application-specific documentation or measure/determine it directly and document it.

Designation / revision: _____

Workpiece material: _____

Workpiece weight [kg]: _____

Dimensions [mm]: _____

Hub opened [mm]: _____

Grip width of the workpiece [mm]: _____

Residual stroke = Space between fingers

in "Gripper open" position – grip width workpiece, residual stroke [mm]:

Special/specific hazards (fragile, sharp edges, hot, etc.):

Identify ambient conditions:

Get the required information from the application-specific documentation or measure it directly and document it. Verify the values using the corresponding operating manual/specifications.

Ambient temperature [°C]: _____

Required IP protection type: _____

Air humidity [%]: _____

Contamination level: _____

Ambient influences:

Warmth Coldness Coolant Abrasive dust

Other: _____

Check protective potential equalisation:

- Check consistency of the protective conductor system according to IEC 60204-1.

After switching on the voltage supply, check:

- The circuits and equipment for the emergency stop function are functional and meet the requirements of the (task-based) risk assessment.

Check requirements for secure holding of the workpiece:

- Supply voltage and the control signal for gripping is on for the required duration (24 VDC / high signal). For further information, see the application-specific documents (e.g. diagrams, operating manual, specifications).
- Supply voltage and drive voltage is at 24 VDC (+/- 10%). If necessary, provide supplementary safety measures.
Measure: _____
- Rest period between two commands is maintained (open / close). To do this, check the application software for control according to specified criteria. Determine successful implementation based on a test run.

relevant /
implemented

During teaching / setup, check the implementation of the defined safety measures with regard to the traverse path:

Examples of task-based considerations show the following sub-items.

- The traverse path matches the requirements of the layout drawing. The alignment of the product prevents workpiece loss even when high dynamic forces are involved (emergency stop).
Example: For parallel grippers with straight gripper fingers, the X-axis of the gripper is aligned with the direction of travel.
- Unusual workpiece dimensions were taken into account when aligning the product. The alignment prevents workpiece loss even with long workpieces (bar shapes).
The risk of workpiece loss is minimized (e.g. by aligning the product correctly)
Measure: _____
- In the event of a workpiece loss, the programmed traverse path does not create a dangerous trajectory, especially not in the direction of the operator/persons (e.g. due to slowed down speed during movements towards the operator (persons); danger-reducing alignment of the product / workpiece; avoidance of unnecessary travel height, and similar measures).
- Ensure that the traverse path and height are optimised to prevent collisions with the head.
Note: Collision with the head should be completely precluded. It may be necessary to implement further and/or supplementary safety measures determined during the (task-based) risk assessment.
Supplementary safety measures:

- The specific hazards of the workpiece have been taken into account (e.g. fragile, sharp, hot workpieces).
 - The control signal for releasing the workpiece is possible only at defined locations. Outside these locations, the control is locked.
 - When empty, the gripper fingers are closed.
The closing process before or during an empty traverse does not cause any danger.
 - The traverse path does not cause any hazards.
Note: It may be necessary to implement supplementary safety measures determined during the (task-based) risk assessment.
Supplementary safety measures:
-

relevant /
implemented

Check the retraction function in the event of an emergency:

Test the retraction function in the event of an emergency during commissioning and once a year:

1. Switch off the supply voltage to the product.
2. Secure it to prevent reactivation.
3. Ensure that the equipment is de-energized: status LED "READY" and "ERROR" are off.
4. Move the gripper fingers manually.
-> If the product is too stiff, return the product to SCHUNK for repair.
-> If not, continue as follows:
5. Remove the safety measures taken to prevent reactivation.
6. Switch on the supply voltage of the product.

Note: If necessary, a device could be installed on the gripper fingers to facilitate this manual test. However, this device itself must not cause a hazardous situation. This must be determined from the (task-based) risk assessment and during operation.

Observe the robot system during operation:

- Collisions are identified and the system reacts accordingly.
- Hazardous collisions are prevented and avoided.

Applied standards:

The integration and operation of the application (including product) has been implemented according to applicable standards / standard parts:

- ISO 12100
- ISO 10218
- ISO/TS 15066
- IEC 60204-1
- further applicable standards/standard parts or technical specifications

The document-related documents for the verification are archived:

- Declaration of Incorporation
- Declaration of Conformity
- Operating manual (if necessary, safety manual, checklists, and similar)

Date of the check:

Name of the checker:

Signature:

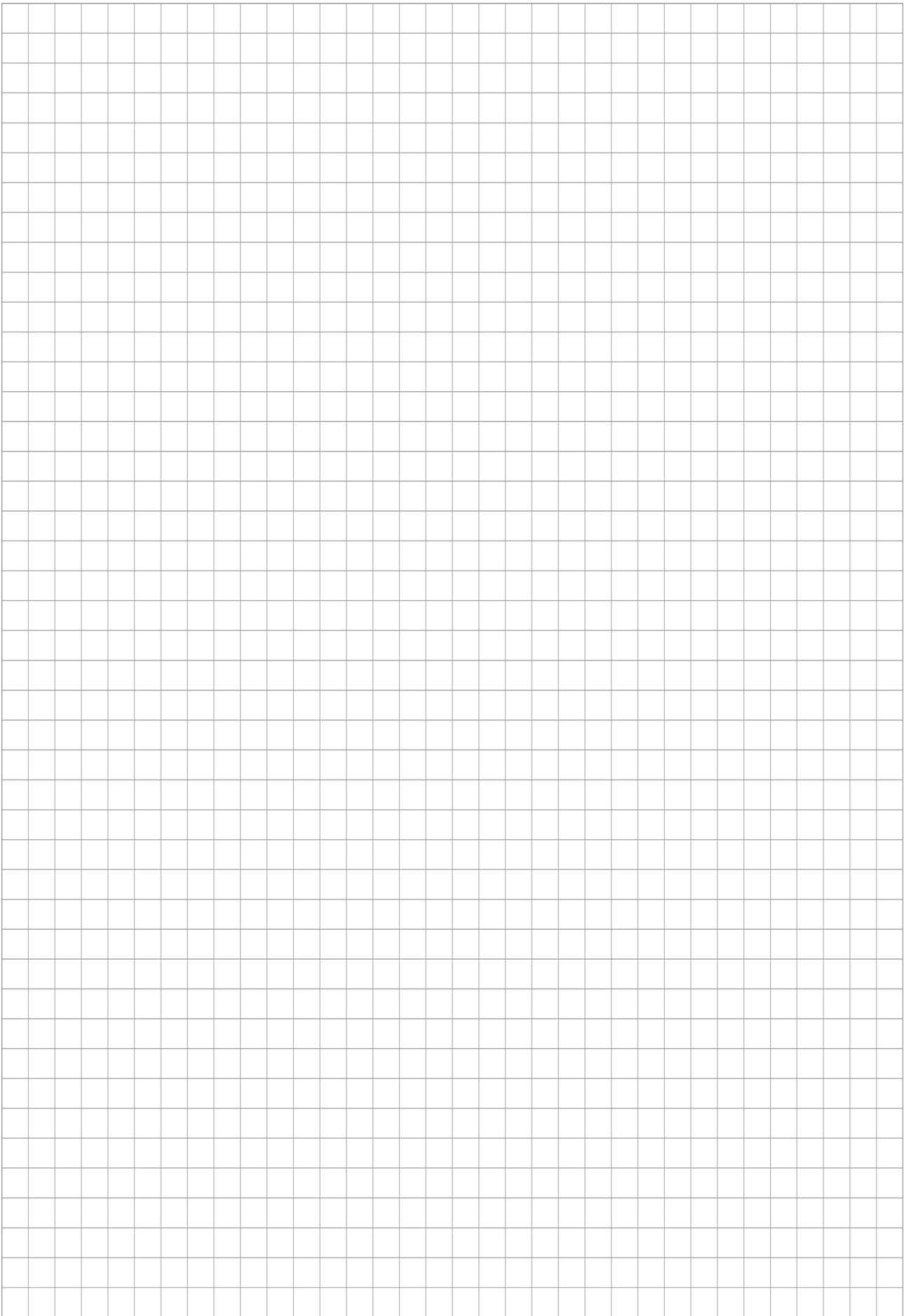

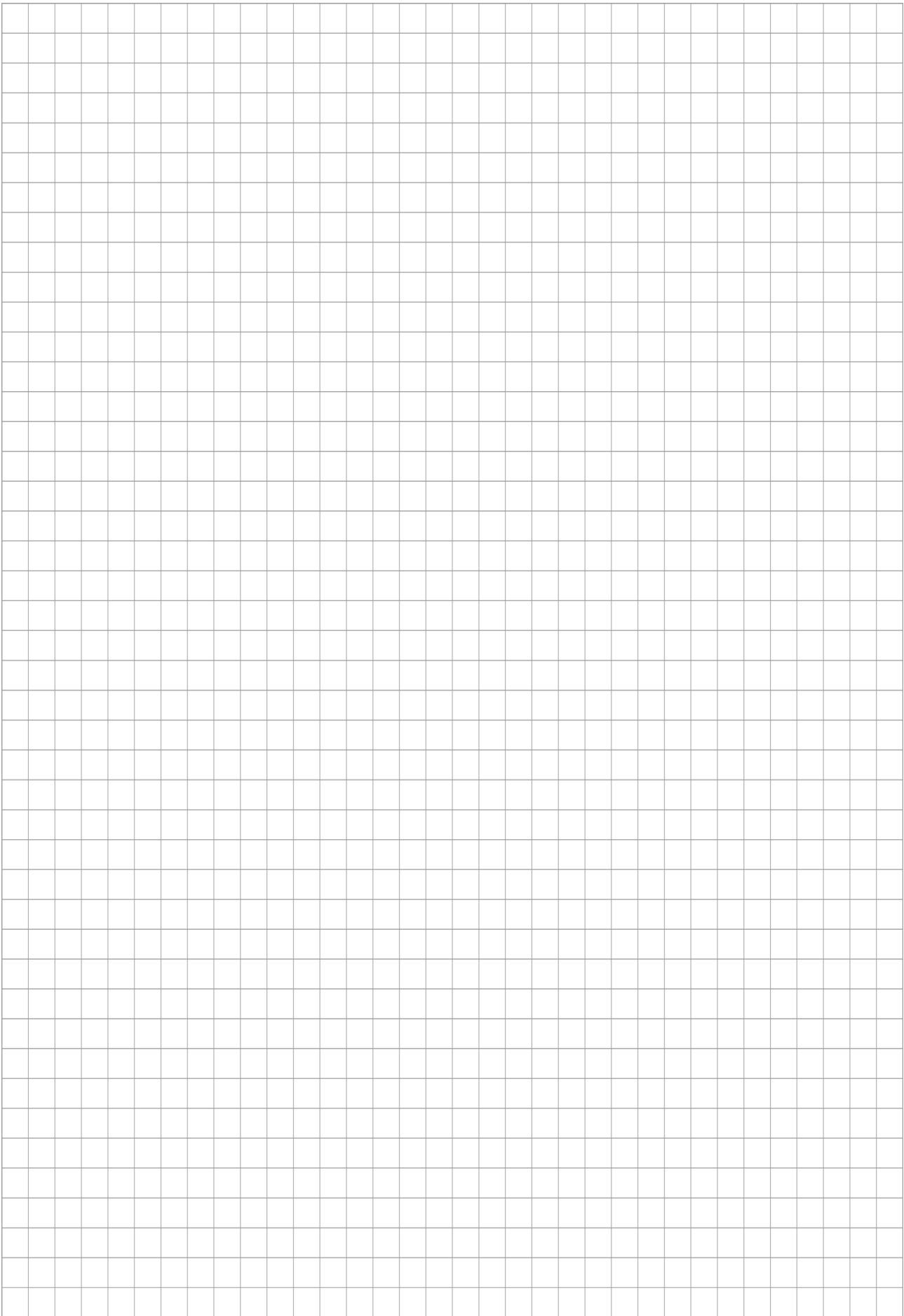



SCHUNK SE & Co. KG
Spanntechnik | Greiftechnik | Automatisierungstechnik

Bahnhofstr. 106 - 134
D-74348 Lauffen/Neckar
Tel. +49-7133-103-0
info@de.schunk.com
schunk.com

Folgen Sie uns | *Follow us*



Wir drucken nachhaltig | *We print sustainable*