



Assembly and Operating Manual

MMS 22-IO-L

Magnetic Switch with IO-Link Interface

Translation of Original Operating
Manual

Hand in hand for tomorrow

Imprint

Copyright:

This manual is protected by copyright. The author is SCHUNK SE & Co. KG.
All rights reserved.

Technical changes:

We reserve the right to make alterations for the purpose of technical improvement.

Document number: 1598377

Version: 02.00 | 18/08/2025 | en

Dear Customer,

Thank you for trusting our products and our family-owned company, the leading technology supplier of robots and production machines.

Our team is always available to answer any questions on this product and other solutions. Ask us questions and challenge us. We will find a solution!

Best regards,

Your SCHUNK team

Customer Management

Tel. +49-7133-103-2503

Fax +49-7133-103-2189

cmg@de.schunk.com



Please read the operating manual in full and keep it close to the product.

Table of Contents

| | |
|---|-----------|
| 1 General | 4 |
| 1.1 About this manual..... | 4 |
| 1.1.1 Applicable documents | 4 |
| 1.2 Warranty | 4 |
| 2 Basic safety notes | 5 |
| 2.1 Intended use..... | 5 |
| 2.2 Inappropriate use | 5 |
| 2.3 Environmental and operating conditions..... | 5 |
| 2.4 Constructional changes..... | 5 |
| 2.5 Personnel qualification | 6 |
| 3 Technical data | 7 |
| 4 Information about the software | 8 |
| 5 Assembly and settings | 9 |
| 5.1 Mechanical connection..... | 9 |
| 5.2 Electrical connection..... | 9 |
| 5.3 Adjusting the sensor | 10 |
| 5.3.1 SIO mode..... | 10 |
| 5.3.2 IO-Link mode | 12 |
| 6 Troubleshooting | 13 |
| 6.1 Sensor is operating, but not as desired | 13 |
| 6.2 In IO-Link mode..... | 14 |
| 6.2.1 LED does not flash (at 1Hz – 90% duty cycle) | 14 |
| 6.2.2 LED flashes at 10Hz and [5] Teach Error is displayed under Sensor Command Reply..... | 14 |
| 6.3 In SIO mode | 14 |
| 6.3.1 Sensor not operating | 14 |
| Declaration of conformity | 15 |
| 7 UKCA Declaration of Conformity | 16 |
| 8 Information on the RoHS Directive, REACH Regulation and Substances of Very High Concern (SVHC) | 17 |

1 General

1.1 About this manual

This manual contains important information for a safe and appropriate use of the product.

This manual is an integral part of the product and must be kept accessible for the personnel at all times.

Before starting work, the personnel must have read and understood this operating manual. Prerequisite for safe working is the observance of all safety instructions in this manual.

1.1.1 Applicable documents

- General terms of business *
- Catalog data sheet of the purchased product *
- Assembly- and Operating Manual of the SCHUNK-module, on which the sensor is mounted *
- "SCHUNK Sensors with IO-Link" software manual *

The documents labeled with an asterisk (*) can be downloaded from [schunk.com/downloads](https://www.schunk.com/downloads).

1.2 Warranty

If the product is used as intended, the warranty is valid for 24 months from the ex-works delivery date under the following conditions:

- Observe the applicable documents, ▶ 1.1.1 [4]
- Observe the ambient conditions and operating conditions, ▶ 2.3 [5]

2 Basic safety notes

2.1 Intended use

The sensor is used for sensing several positions of a SCHUNK product via a magnetic control cam or a specific magnetic field with IO-Link communication.

- The product is intended for installation in a machine/ automated system. The applicable guidelines for the machine/ automated system must be observed and complied with.
- The product may only be used within the scope of its technical data, ▶ 3 [7].

2.2 Inappropriate use

The product is not a safety component in accordance with the EC Machine Directive 2006/42/EC and must not be used in safety-relevant parts of machine control units.

2.3 Environmental and operating conditions

Required ambient conditions and operating conditions

Incorrect ambient and operating conditions can make the product unsafe, leading to the risk of serious injuries, considerable material damage and/or a significant reduction to the product's life span.

- Make sure that the product is used only in the context of its defined application parameters, ▶ 3 [7].
- Make sure that the environment is free from splash water and vapors as well as from abrasion or processing dust. Exceptions are products that are designed especially for contaminated environments.

2.4 Constructional changes

Implementation of structural changes

Modifications, changes or reworking, e.g. additional threads, holes, or safety devices, can damage the product or impair its functionality or safety.

- Structural changes should only be made with the written approval of SCHUNK.

2.5 Personnel qualification

Inadequate qualifications of the personnel

If the personnel working with the product is not sufficiently qualified, the result may be serious injuries and significant property damage.

- All work may only be performed by qualified personnel.
- Before working with the product, the personnel must have read and understood the complete assembly and operating manual.
- Observe the national safety regulations and rules and general safety instructions.

3 Technical data

| Designation | MMS 22-IOL |
|--------------------------|------------|
| Ambient temperature [°C] | |
| Min. | + 5 |
| Max. | + 55 |
| Nominal voltage [VDC] | 24 |
| Min. | 18 |
| Max. | 30 |
| IP rating | 67 |
| Communication interface | IO-Link |
| Specification: | V1.1 |
| Transmission rate | COM 2 |
| Port | Class A |

More technical data is included in the catalog data sheet.
Whichever is the latest version.

4 Information about the software

To operate the sensor with IO-Link, an IO-Link master and corresponding software are required.

The IODD required for operation can be downloaded from [schunk.com](https://www.schunk.com) or ioddfinder.io-link.com.

5 Assembly and settings

5.1 Mechanical connection

NOTE

The assembly instructions in this chapter are generally applicable.

Module-specific assembly instructions for the sensor can be found in the Assembly and Operating Manual for the module, which can be downloaded at schunk.com

NOTICE

Material damage due to an incorrect tightening torque!

If the threaded pin is tightened with an incorrect tightening torque, the product may be damaged.

- Observe a maximum tightening torque of 10 Ncm for the set-screws.

5.2 Electrical connection

NOTICE

Material damage due to incorrect bending radii!

The product may get damaged if the bending radius of the cable is less than the minimum.

- See catalog datasheet for corresponding details.

NOTE

- Do not use the sensor as a safety component.
- Do not pull on the cable of the sensor.
- Secure the cable and connector so that they are not taught and cannot move during operation.
- Do not exceed the permitted bending radius of the cable.
- Do not allow the sensor to come into contact with hard objects or chemicals (e.g. nitric, chromic and sulfuric acid)

Ferromagnetic components change the magnetic field and the function of the sensor, e.g. adapter plate made of construction steel. For ferromagnetic adapter plates:

- First, install the module on the adapter plate.
- Then teach in sensor.

The sensor is an electronic component that can be sensitive to high-frequency interference or electromagnetic fields.

- Check whether there is sufficient distance between the sensor and sources of interference and their supply cables.

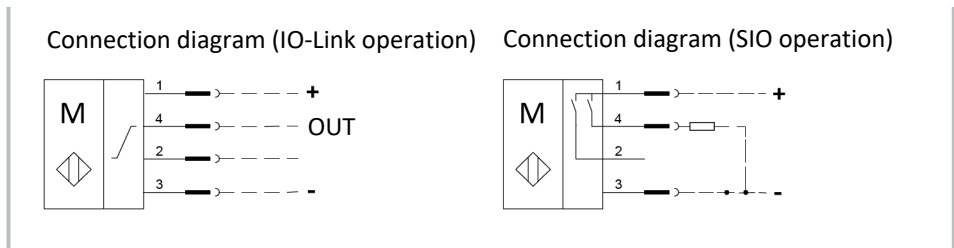

| | |
|--------------------|----------|
| Type of switching | PNP |
| Switching function | Closer |
| Cable length [m] | 0.3 |
| Connector | M8 / M12 |

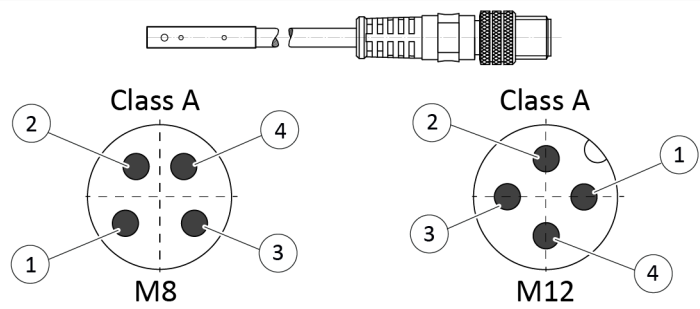

| Pin | Signal | Description |
|-----|--------|---|
| 1 | L+ | +24 V |
| 2 | I/Q | not assigned |
| 3 | L- | GND |
| 4 | C/Q | Switching signal DI (SIO) or IO-Link (SDCI) |

5.3 Adjusting the sensor

NOTE

The difference between the teach and operating temperatures must not exceed 30 K.

5.3.1 SIO mode

In SIO mode (Standard IO-mode), the sensor can be used to determine a switching point. The sensor is adjusted purely mechanically. An IO-Link master is not required and additional teaching is not necessary.

- If a clamping stop (3) is in the groove, it must be removed.
- 1. Place the module in switching position.
- 2. Push the sensor (1) into the groove (2) until it stops at the housing.

3. Pull the sensor (1) back again slowly until it switches (LED lights up).
4. Tighten the set-screw (4) to clamp the sensor (1) in this position in the groove (2).
5. Test the switching position.

NOTE

The sensor is automatically set to SIO mode if there is no IO-Link communication.

To do this, either the IO-Link port on the IO-Link master can be parameterized accordingly (e.g. from Digita In instead of IO-Link), or the sensor can be connected to +24V and GND only.

Adjusting sensor with teach-in tool (sensor in SIO mode)

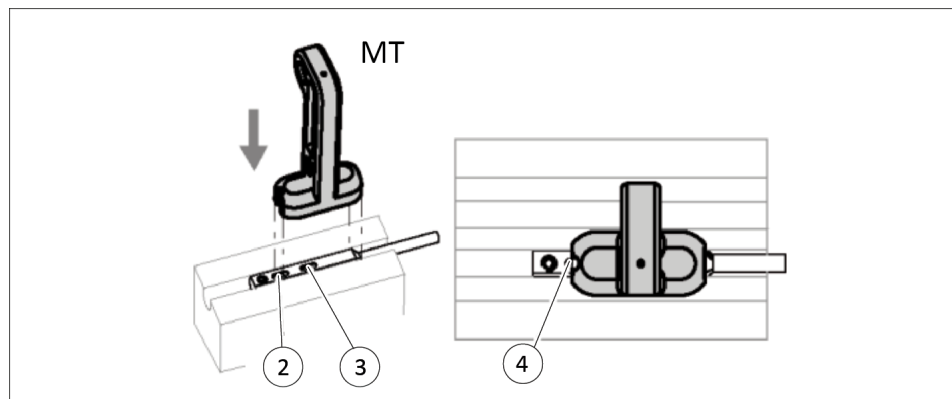

Positioning the magnet teach-in tool (MT)

1. The sensor can only be programmed in SIO mode using the teaching tool.
To do this, set the sensor to SIO mode. ▶ 5.3.1 [10]
2. Move module to end position 1 (e.g. gripper open).
3. Place the magnet teach-in tool (MT) on the sensor (4) for at least approx. 1 second.
4. Remove the MT
⇒ After 3 seconds, the LED flashes at 1 Hz (50% duty cycle).
5. Move module to end position 2 (e.g. gripped closed).
⇒ LED flashes at 2 Hz.
6. Place the MT on the sensor (4) for at least approx. 1 second.
⇒ LED flashes at 6 Hz.
7. Remove the MT
⇒ LED flashes for a further 5 seconds at 6 Hz.
⇒ The switching positions of the end positions are now set.
8. In case of poor magnetic field:
⇒ LED flashes at 10 Hz for 10 seconds ▶ 6.2.2 [14].

NOTE

The setting procedure is canceled after 30 s if the MT is not inserted again.

5.3.2 IO-Link mode

In IO-Link mode, the sensor is used to record positions on SCHUNK products. To do so, the exact limits must be taught in. This can be done with a teach-in tool (sensor in SIO mode) or by the software (sensor in IO-Link mode via IO-Link master).

Adjusting sensor with software (via IO-Link master – sensor in IO-Link mode)

- LED flashes at 1 Hz (90% duty cycle) if there is an IO-Link connection.
- 1. Move module to end position 1.
- 2. Sensor Teach command: Select *[3] Start teaching Magnetic field*.
- 3. Run *Write to device (download)*.
 - ⇒ After 5 seconds, the LED flashes at 1 Hz (50% duty cycle).
 - ⇒ Sensor Command Reply: *[1] Teaching started* is displayed.
- 4. Within 12 seconds, move module to end position 2.
 - ⇒ LED flashes for 1 second at 2 Hz.
 - ⇒ Sensor Command Reply: *[2] Teaching finished* is displayed.
- 5. Select *Save Data*.
 - ⇒ LED flashes for 1 second at 6 Hz and then again at 1 Hz.
 - ⇒ Sensor Command Reply: *[3] Saving data done* is displayed.
- 6. If the magnetic field is poor, *[5] Teach Error* is displayed under Sensor Command Reply.
 - ⇒ LED flashes at 10 Hz.
- 7. Commands: Select *[4] Canceled*.
 - ⇒ LED flashes at 1 Hz (90% duty cycle).

6 Troubleshooting

6.1 Sensor is operating, but not as desired

| Possible cause | Sources of interference | Corrective action |
|---|---|---|
| The sensor is interfered with or influenced by external magnetic or soft magnetic materials (Fe). | Motors (coils) | Increase the distance between the sensor and sources of interference (until the sensor operates correctly). |
| | Relays | |
| | Linear motors | |
| | Electrical welding | |
| The sensor is influenced by a different sensor. | Magnetized workpieces (workpieces made of iron (Fe) or similar materials) | Use finger attachments made of aluminum. |
| | Magnetized components and tools made of iron (adapter plates made, screws or hexagon socket keys, etc.) | Use components containing aluminum. V4A screws are recommended. |
| The sensor is affected by deposits of magnetic chips in the vicinity (in the air gap). | Liquids with magnetic chips or the like. | Regularly clean the immediate environment of the sensor. (The higher the exposure to such fluids, the more often it needs to be cleaned.) |
| The sensor is affected by the directly adjacent module. | Built-in magnets in the piston of the adjacent module | Increase the distance to the adjacent module to at least 10 mm. |

NOTE

If these steps do not eliminate the problem, contact SCHUNK Service for troubleshooting.

6.2 In IO-Link mode

6.2.1 LED does not flash (at 1Hz - 90% duty cycle)

| Possible cause | Corrective action |
|---------------------------------|---|
| No voltage supply | Check the voltage supply and apply voltage if necessary |
| Sensor cable broken | Replace sensor cable |
| IO-Link connection disconnected | Establish IO-Link connection via software |

6.2.2 LED flashes at 10Hz and [5] Teach Error is displayed under Sensor Command Reply

| Possible cause | Corrective action |
|---|---|
| Poor magnetic field -> sensor mounted at incorrect position | Mount sensor in the correct position as per the gripper's Assembly and Operating Manual |

6.3 In SIO mode

6.3.1 Sensor not operating

1. Check whether the sensor cable is broken.
2. Check whether the voltage at the sensor is between 18 - 30 VDC.
3. Check whether the LED lights up at the position to be sensed and that the sensor is operating.

NOTE

If the LED does not light up or the sensor is not operating, contact SCHUNK Service.

Declaration of conformity

Manufacturer/
Distributor

SCHUNK SE & Co. KG
Spanntechnik | Greiftechnik | Automatisierungstechnik
Bahnhofstr. 106 – 134
D-74348 Lauffen/Neckar

Product designation: Magnetic Switch with IO-Link Interface MMS 22-IOL
ID number 0315830, 0315835

We hereby declare that the product complies with all relevant harmonization legislation of the following directives at the time of declaration.

The declaration is rendered invalid if modifications are made to the product.

- **Electromagnetic compatibility (EMC directive) 2014/30/EU**

Applied harmonized standards, especially:

EN IEC 61000-6-2:2019 Electromagnetic compatibility (EMC) – Part 6-2:
Generic standards – Immunity standard for industrial
environments

EN 61000-6-4:2007 + A1:2011 Electromagnetic compatibility (EMC) – Part 6-4: Generic standards –
Emission standard for industrial environments
(IEC 61000-6-4:2006 + A1:2010);

EN 60947-5-2:2007 + A1:2012 Low-voltage switchgear and controlgear –
part 5-2: circuit devices and switching elements –
Proximity switches (IEC 60947-5-2:2007 + A1:2012)

Signed for and on behalf of: SCHUNK SE & Co. KG

Lauffen/Neckar, August 2025

i.V. Nico Peper;
Director Software and Electronics;
Technology & Innovation

7 UKCA Declaration of Conformity

Manufacturer/
Distributor SCHUNK Intec Limited
 Clamping and gripping technology
 3 Drakes Mews, Crownhill
 MK8 0ER Milton Keynes

Product designation: Magnetic Switch with IO-Link Interface MMS 22-IOL
ID number 0315830, 0315835

We hereby declare that the product complies with all relevant harmonization legislation of the following directives at the time of declaration.
The declaration is rendered invalid if modifications are made to the product.

- **Electromagnetic Compatibility Regulations 2016**

Applied harmonized standards, especially:

EN IEC 61000-6-2:2019 Electromagnetic compatibility (EMC) – Part 6-2:
 Generic standards – Immunity standard for industrial environments

EN 61000-6-4:2007 + Electromagnetic compatibility (EMC) – Part 6-4: Generic standards –
A1:2011 Emission standard for industrial environments
 (IEC 61000-6-4:2006 + A1:2010);

EN 60947-5-2:2007 + Low-voltage switchgear and controlgear –
A1:2012 part 5-2: circuit devices and switching elements –
 Proximity switches (IEC 60947-5-2:2007 + A1:2012)

Person authorized to compile the technical documentation:
Marcel Machado, address: refer to manufacturer's address

Signed for and on behalf of: SCHUNK SE & Co. KG

Lauffen/Neckar, August 2025



i.V. Nico Peper; Director Software and Electronics; Technology & Innovation

8 Information on the RoHS Directive, REACH Regulation and Substances of Very High Concern (SVHC)

RoHS Directive

SCHUNK products are classified as "large-scale stationary installations" or as "large-scale stationary industrial tools" within the meaning of Directive 2011/65/EU and its extension 2015/863/EU "on the restriction of the use of certain hazardous substances in electrical and electronic equipment (RoHS)", or fulfill their intended function only as part of one. Therefore products from SCHUNK do not fall within the scope of the directive at this time.

REACH Regulation

Products from SCHUNK fully comply with the regulations of Regulation (EC) No. 1907/2006 "concerning the Registration, Evaluation, Authorization and Restriction of Chemicals (REACH)" and its amendment 2022/477. SCHUNK attaches great importance to completely avoiding chemicals of concern to humans and the environment wherever possible.

Only in rare exceptional cases do SCHUNK products contain SVHC substances on the candidate list with a mass content above 0.1%. In accordance with Article. 33 (1) of Regulation (EC) No. 1907/2006, SCHUNK complies with its duty to "communicate information on substances in articles" and lists the components concerned and the substances used in an overview that can be viewed at [schunk.com/SVHC](https://www.schunk.com/SVHC).

Signature: see original declaration

Lauffen/Neckar, August 2025

Dr.-Ing. Manuel Baumeister,
Head of Systems Engineering,
Technology & Innovation

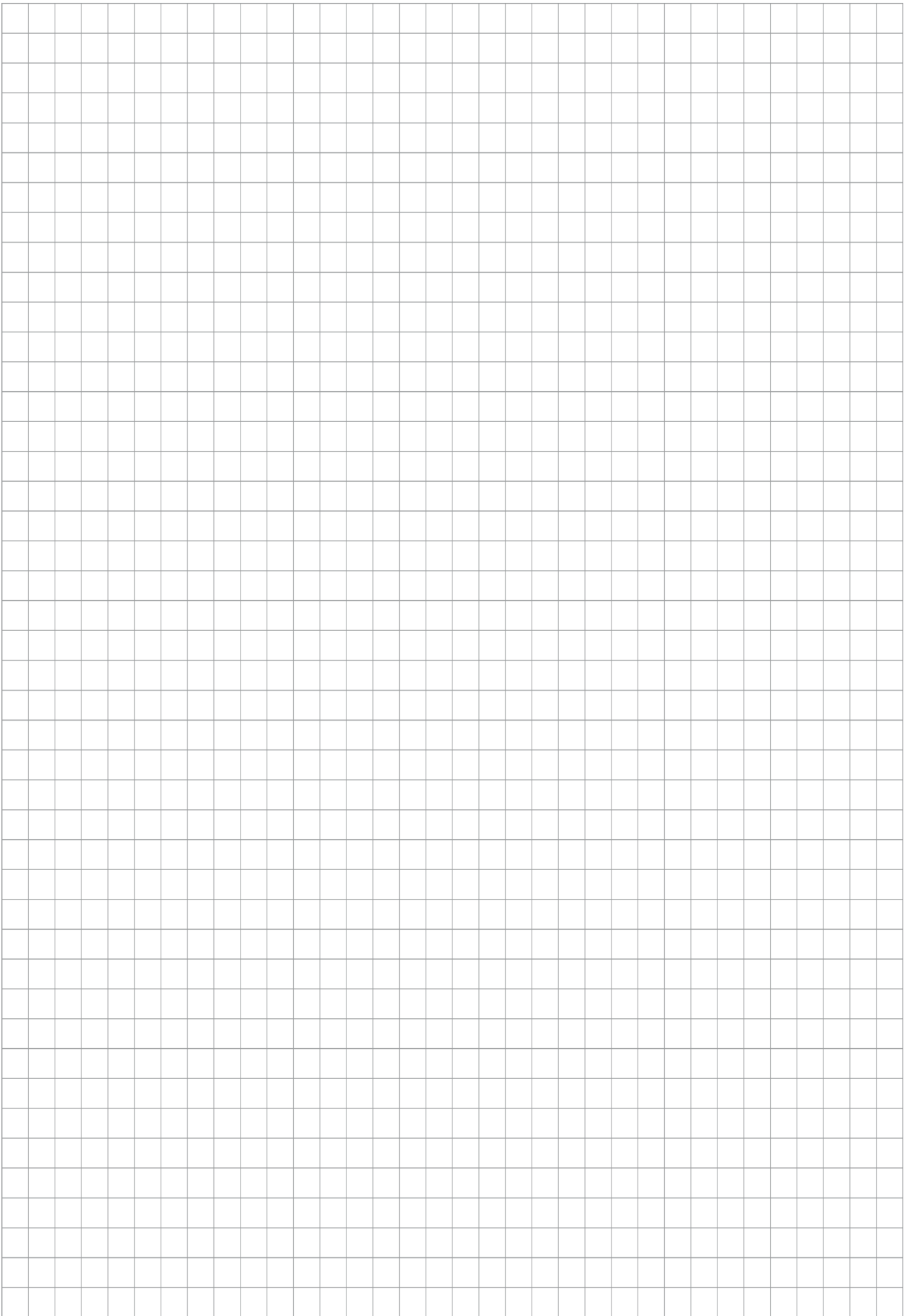

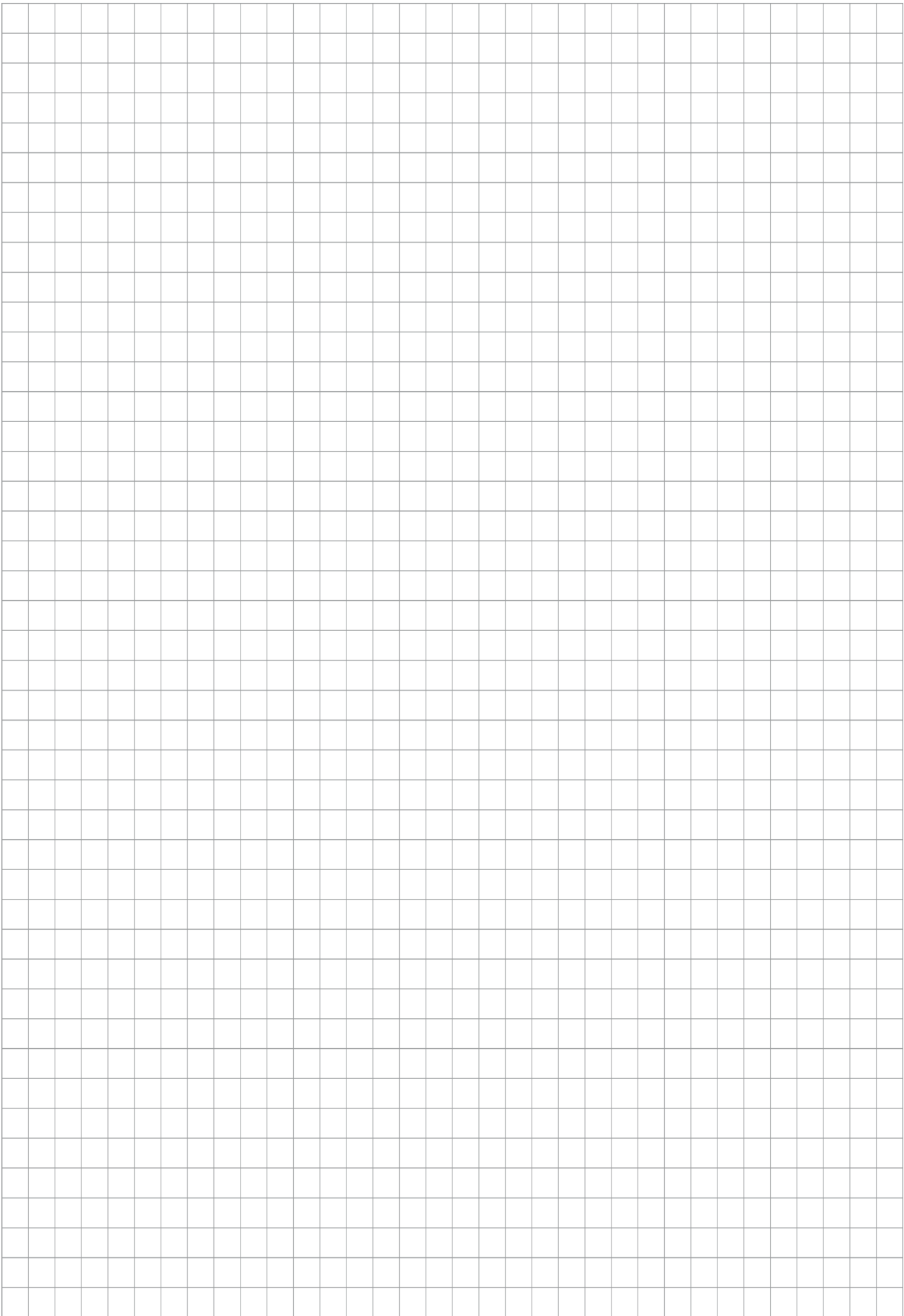



SCHUNK SE & Co. KG
Spanntechnik | Greiftechnik | Automatisierungstechnik

Bahnhofstr. 106 - 134
D-74348 Lauffen/Neckar
Tel. +49-7133-103-0
info@de.schunk.com
schunk.com

Folgen Sie uns | *Follow us*



Wir drucken nachhaltig | *We print sustainable*