

Montage- und Betriebsanleitung Installation- and operating instruction

Doppelspanner
Double vice

KSC-D 125



H.-D. SCHUNK GmbH & Co.
Spanntechnik KG
Lothringer Strasse 23
D-88512 Mengen

Table of contents:



1	User information	20
1.1	Purpose of document, validity	20
1.2	Illustration of safety instructions	20
2	General safety instructions	21
2.1	Intended use	21
2.1.1	Technical data	21
2.2	Reasonably foreseeable misapplication	22
2.2.1	Alterations and modifications.....	22
2.2.2	Spare and wear parts and auxiliary material.....	22
2.3	Residual risk	22
2.3.1	Jaw change	22
2.3.2	Notes on clamping technology.....	22
2.4	Duties of the organisation in charge.....	23
2.5	Operator duties.....	23
2.6	Operator qualification	23
2.7	Personal protective equipment.....	23
2.8	Warranty	23
3	Description of the clamping device	24
3.1	Application	24
3.1.1	Adjusting jaws.....	24
3.1.2	Setting up the third-hand function.....	25
3.1.3	Clamping process	25
4	Operation (standard operation)	25
4.1	Clamping / aligning	25
4.2	Corrosion	26
4.3	Jaw range	26
4.4	Jaw change.....	26
5	Servicing, cleaning and maintenance	27
5.1	General cleaning / lubrication.....	27
6	Troubleshooting, eliminating faults	28
7	Removal	28
8	Assembly	29
9	Assembly drawing	30
9.1	Parts list.....	31
10	Swivel and adapter plate	33
10.1	Function.....	33
10.2	Servicing, cleaning, maintenance	33
10.3	Troubleshooting, eliminating faults.....	33
10.4	Removing and replacing parts	34
10.5	Fitting the 6-fold reversible jaws.....	34
11	Aluminium jaws	34
12	Fixed jaw vise	35
13	Positioning bar	35
14	Taking out of service	35



1 User information



1.1 Purpose of document, validity

These instructions are an integral part of the product supplied and contain important information for the safe installation, commissioning, operation, servicing and maintenance. These instructions must be read before using the product and must be observed during operation, in particular the "General safety instructions" section.

1.2 Illustration of safety instructions

DANGER 	
	<p>Indicates imminent danger. If the information is ignored, death or serious injury (permanent disability) will result.</p>

WARNING 	
	<p>Indicates a potentially dangerous situation. If the information is ignored, it is possible that death or serious injury (permanent disability) will result.</p>

WARNING 	
	<p>Indicates a potentially dangerous situation. If the information is ignored, it is possible that material damage and light to medium injury will result.</p>

Information on useful tips or for preventing material damage

NOTE	
	<p>Indicates general information, useful tips for users and work recommendations which do not impact on the health and safety of operators.</p> <p>... underscores useful tips and recommendations as well as information for efficient and trouble-free operation.</p>

Important for preventing more extensive material damage

CAUTION	
	<p>Indicates a potentially dangerous situation. If the information is ignored, material damage will result.</p> <p>... points out a potentially dangerous situation that can lead to material damage if it is not avoided.</p>

2 General safety instructions

2.1 Intended use

The clamping device may only be used in accordance with the technical data and has been designed for stationary application on milling machines in an industrial environment. Using the device in accordance with the intended purpose includes compliance with the commissioning, installation and operating instructions, and with the environmental and service conditions as provided by the manufacturer. The manufacturer accepts no liability for damage resulting from non-intended use.

2.1.1 Technical data

Version	max. torque	max. clamping force
KSC-D 125	100 Nm	40 kN

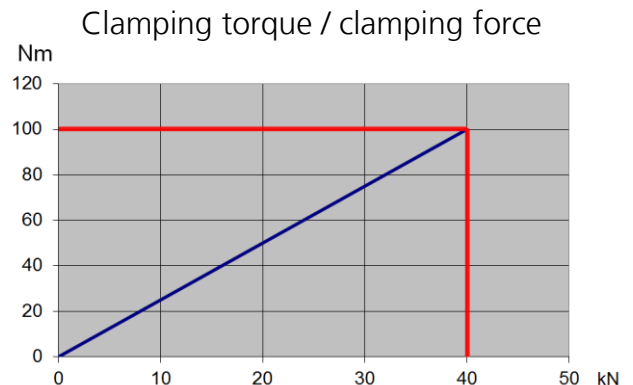

Exposure to loads in excess of the max. clamping torque results in damage to the spindle.



Weight:

KSC-D 125-320 without system jaws:	14.0 kg
KSC-D 125-390 without system jaws:	17.0 kg
KSC-D 125-460 without system jaws:	20.0 kg
KSC-D 125-530 without system jaws:	24.0 kg
KSC-D 125-600 without system jaws:	27.0 kg
KSC-D 125-670 without system jaws:	30.0 kg
KSC-D 125-740 without system jaws:	34.0 kg

For further data, please see the catalogue >> Schunk stationary Workholding <<

2.2 Reasonably foreseeable misapplication

Any application that is not in accordance with the "Intended use" or exceeds such intended use is considered not in accordance with the regulations, and is forbidden. Any other use of the device is subject to confirmation from the manufacturer.



Examples of foreseeable misapplication

- Clamping device used on rotating systems.
- Clamping widely protruding workpieces.
- Clamping workpieces with a weight of over 20 kg in vertical position without an additional safeguard to prevent the workpiece falling out.

2.2.1 Alterations and modifications

In the case of unauthorised alterations and modifications of the clamping device, the manufacturer's liability ceases and any warranty is voided.

2.2.2 Spare and wear parts and auxiliary material

Only use original parts or parts approved by the manufacturer. Using spare and wear parts by third party manufacturers may lead to risk.

2.3 Residual risk

The user is responsible for applying the correct workpiece tension.

New clampings have to be carefully checked by qualified personnel with relevant training.

One always needs to allow for the risk that the workpiece may slip or be dislodged, even when the clamping device is functioning correctly. This is due to the different geometries to be clamped, contact surfaces, clamping friction values, processing force, wrong manipulation of the milling machine etc.

Protective devices are to be attached to the processing machine that will protect the operator from any tool or workpiece parts that may be ejected.

It is mandatory that operators and others in the proximity of the processing machine wear protective goggles.

Do not use methods of operation that impair the function and operational safety.



2.3.1 Jaw change

Damage may result if system jaws are insufficiently tightened.



2.3.2 Notes on clamping technology

The operator is responsible for ensuring that the clamping geometry and clamping forces are suitable for the intended processing.

We recommend that clamping be carried out with a torque wrench in order to achieve consistent clamping results.

The clamping forces can only be achieved if the clamping device functions correctly and the workpiece is correctly held in the device.

Regular servicing and cleaning in accordance with the operating instructions is mandatory in order to ensure correct function.

When clamping thin-walled elastic workpieces, e.g. tubes or packages, it is possible that the clamping force is significantly reduced due to yielding of the workpiece.

When clamping with a high degree of force, the clamping force is significantly reduced due to the increased frictional forces in the carriages.



2.4 Duties of the organisation in charge

The organisation in charge of the device undertakes to only allow operatives to work on the device:

- who are familiar with the basic health and safety regulations and regulations for the prevention of accidents.
- who have completed appropriate induction for working with the machine.
- who have read and understood these operating instructions.

The requirements of the EC Directive 2007/30/EC on the use of work machinery must be complied with.

2.5 Operator duties



All persons who have been instructed to work with the machine undertake to:

- observe the basic regulations for health and safety and for the prevention of accidents.
- read and understand the section on safety and the safety instructions in these operating instructions prior to working with the machine, and to observe these instructions.

2.6 Operator qualification

The installation, initial setup, fault analysis and periodic monitoring have to be carried out by competent personnel with the relevant qualifications.

2.7 Personal protective equipment

WARNING 	
	<p>Risk of eye injury through ejected, hot fragments! Ejected hot fragments can lead to serious eye injury. The regulations for safety at work and the prevention of accidents always have to be observed when working with the machine. Personal protection equipment must be worn at all times, in particular safety boots, gloves and safety goggles.</p>

2.8 Warranty

The warranty period is 24 months from the date of delivery; the warranty applies subject to being used as intended and to the following conditions:

- Compliance with concurrent documents.
- Compliance with environmental and operating conditions.
- Compliance with the specified maintenance and lubrication intervals.
- Observance of the maximum service life.

Any parts in contact with workpieces are not covered by the warranty.

Warranty – maximum service life

Warranty period	24 months
Maximum service life [clamping cycles]	50,000

3 Description of the clamping device

The KSC-D has been designed as a double vice to clamp two parts, raw parts and processed workpieces.

The force is built up mechanically and applied via a trapezoidal thread featuring a bearing that has been sealed on one side. The power gear ratio is linear across the entire clamping range.

The entire vice has been encapsulated from the top and front and can be cleaned using compressed air.

The third-hand operation function when clamping is guaranteed by pre-clamping the rear carriage using a pressure spring.

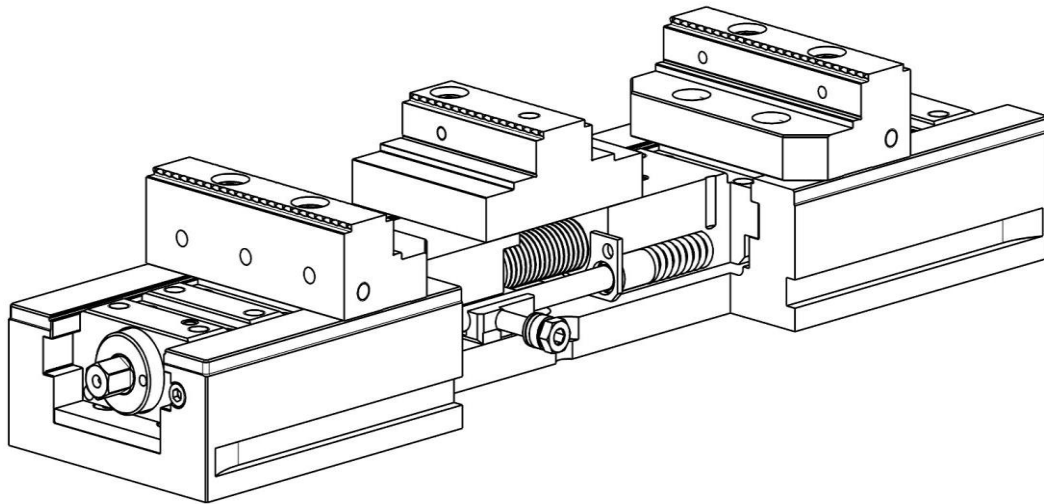

3.1 Application

3.1.1 Adjusting jaws

For two identically sized or differently sized workpieces

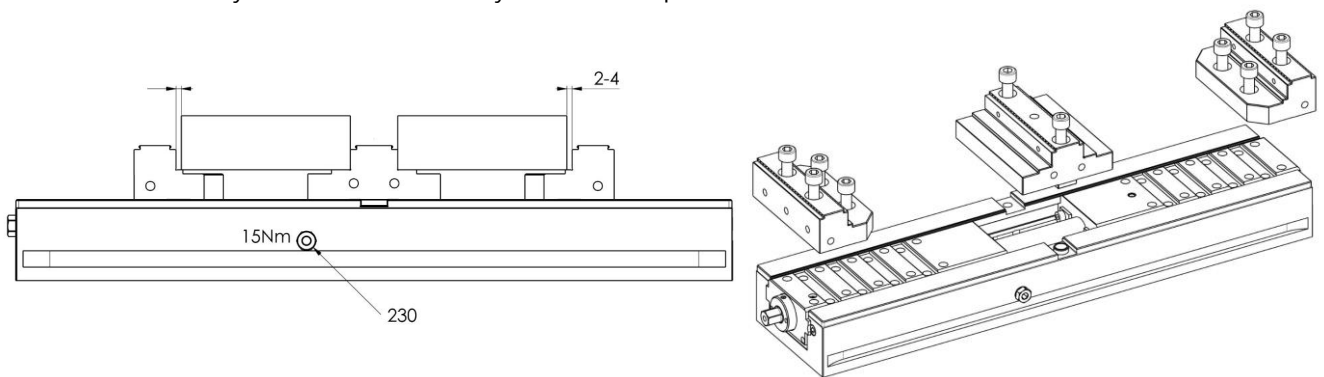

Important:

The lateral clamping screw (pos. 230) has not been tightened, open by approximately ½ turn 

Fully open the vice and position the moving clamping jaws in the matching grooves of the moving carriages depending on the workpiece size and tighten the cylinder screws M10 with property class 12.9 with torque 60 Nm.

Since the carriage have a maximum adjustment range of 45 mm, it is possible to clamp two workpieces with different sizes. If this is insufficient, the system jaws can be moved by 35 mm into another groove of the carriage. 

3.1.2 Setting up the third-hand function

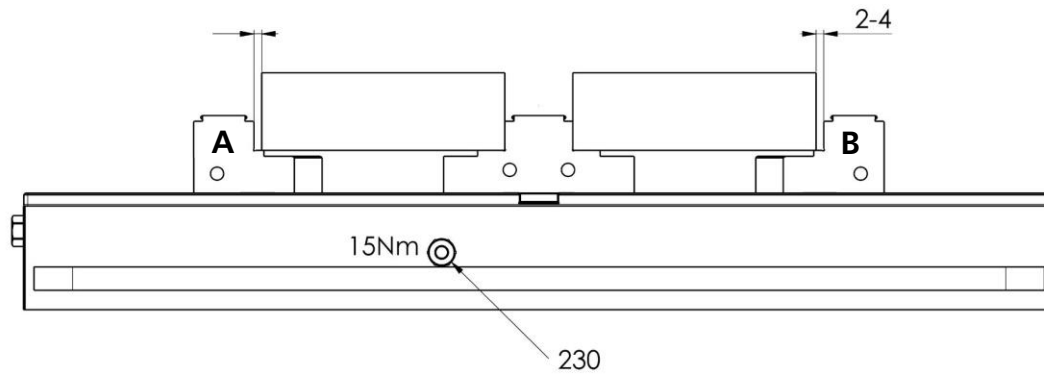

Insert the workpiece and move the jaws together so that rear jaw **B** is at 2–4 mm from the workpiece.

Tighten the lateral clamping screw (pos. 230) to 15 Nm.

Exceeding the clamping torque by 15 Nm may lead to damage on the clamping unit.



3.1.3 Clamping process

By clamping the rear carriage that has been pre-tensioned using a spring, it is possible to guarantee that when you close the vice, the front clamping jaw **A** is guided to the workpiece first where it pre-tensions to around 500 N. After the front jaw **A** comes into contact with the workpiece, the rear clamping jaw **B** starts to close. Once both workpieces have been clamped, the last step is to completely apply the entire clamping torque.

When opening the clamping jaws the workpiece at the rear clamping jaw **B** is released before the workpiece at the front clamping jaw **A** is released (after the third-hand function has fully retracted).

4 Operation (standard operation)

4.1 Clamping / aligning

Push parts of the entire carriage unit from the base body to attach the vice.

For this purpose, see **Section 7 Removal** and **Section 8 Assembly**.

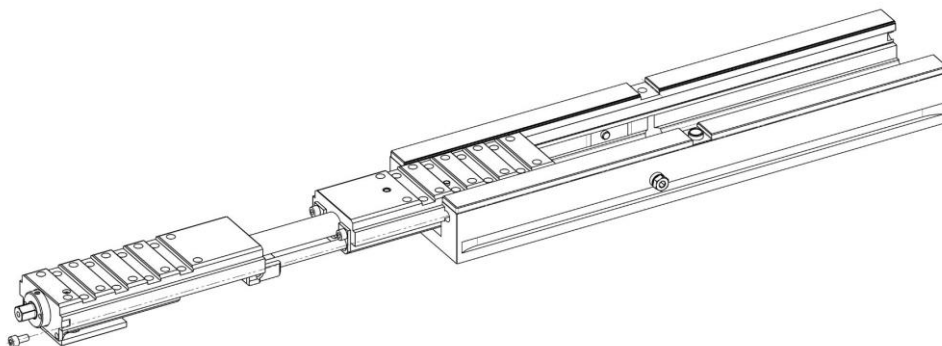

Important:

The base body and entire carriage must not be interchanged.

The parts have been manufactured together and are not interchangeable.



The KSC-D offers a host of attachment options on the supporting table that have all been integrated into the device.

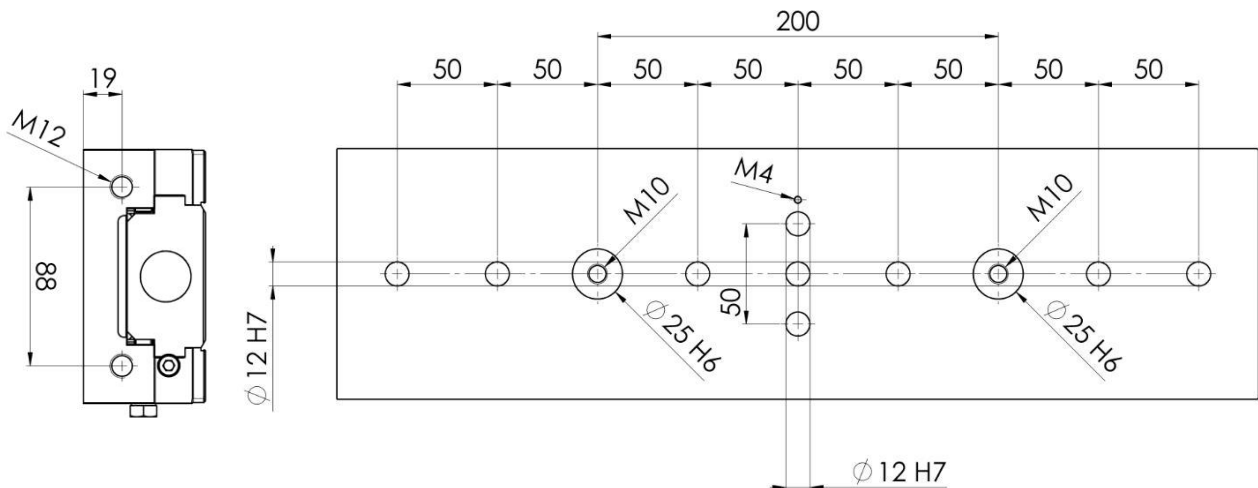

(Illustration of principle: KSC-D 125 L-460)

The following interfaces are included in the basic variant:

Positioning holes $\text{Ø}12 \text{ H}7$ to align the vice.

Positioning holes $\text{Ø}12 \text{ H}7$ so the vice can be positioned and secured to grid plates with a size 50 and on T-slot tables using fitting screws $\text{Ø}12 \text{ f}7/\text{M}12$ or cylinder screws M12.

Locating holes $\text{Ø}25 \text{ H}6$ for the clamping pin of the VERO-S quick-change palleting system.

Important:

When using VERO-S clamping bolts, make sure that a shortened screw is used, otherwise the slide may be damaged. (See Schunk catalogue)

Longitudinal grooves to attach clamping claws.

Attachment thread M4 in the base body for alignment using alignment and centring sets.

Threads M12 at the front on reference surface.

The KSC-D can also be produced at the factory with customer-specific positioning and fixing holes as well as with location recesses for various commonly available quick-change palleting systems.



4.2 Corrosion

The KSC-D's base body has been nickel-plated. Carriages and jaws are made of steel. Well-maintained coolant is necessary to guarantee ideal functionality which must demonstrate specified concentrations, pH values and conductivity properties.

Deviations from manufacturer data may lead to a formation of corrosion.

4.3 Jaw range

The reliable function of the clamping device is significantly affected by the selection of the correct top jaws.

4.4 Jaw change

- Release cylinder screws and remove the jaws.
- Clean and oil the contact surfaces, e.g. with MOTOREX Supergliss 68 K to ISO VG 68.
- Changing the jaws or moving them in the carriages, tightened the cylinder screw (12.9) with a torque of 60 Nm.

5 Servicing, cleaning and maintenance

No special maintenance required, the spindle and the internal vice components have been protected by the carriage and central jaw design. Regularly grease carriage contact surfaces, e.g. with MOTOREX Supergliss 68 K to ISO VG 68.

We recommend cleaning the double vice when replacing jaws as these components are fast and easy to remove.

Regularly clean the vice through the two cleaning holes on the face of the front carriage using a compressed-air gun to prevent deposits of small chips and swarf.



5.1 General cleaning / lubrication

Lubricate the lubrication nipples (pos. 200) on both carriages using multi-purpose grease once a month. For this purpose, turn the carriages towards the far inside.

If you have applied excessive amounts of grease, it may be possible that the closing disc (pos. 170) in the carriage (pos. 60) is pressed out.



6 Troubleshooting, eliminating faults

Clamping using the lateral clamping screw (pos. 230) is not possible

The clamping element on the inside is not in the correct position.

See **Section 8 Assembly**

Unable to disassemble the carriage unit from the base body

- Unscrew the clamping screw. (pos. 230)
- Remove the central jaw and blow-out the body through the blow-out holes on the front carriage. (pos. 70)

Important:

Vice functions can exclusively be guaranteed if the central jaw has been installed.

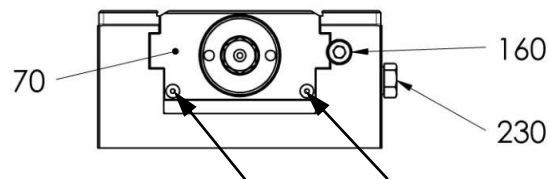

- Cylinder screw (pos. 160) has not been removed.

7 Removal

Removing the carriage unit

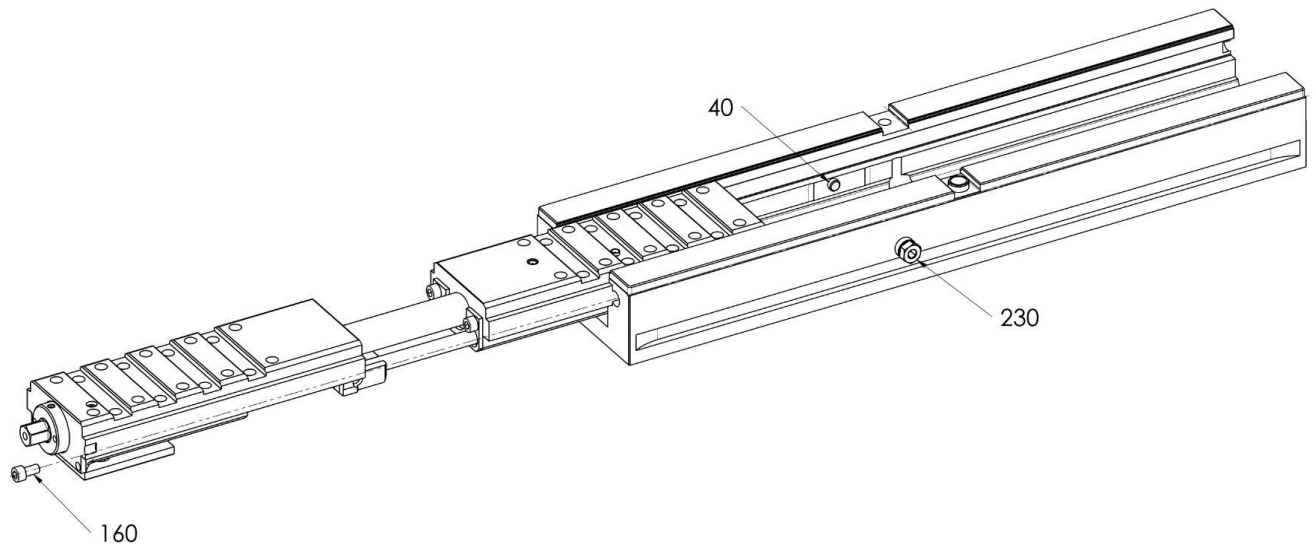

- Removing the system jaws.
- Remove the cylinder screw (pos. 160).
- Undo the clamping screw (pos. 230) by a minimum of 4 turns. Cylinder screw (pos. 40) must never be unfastened.
- Pull the entire carriage unit from the base body.

8 Assembly

Installing the carriage unit

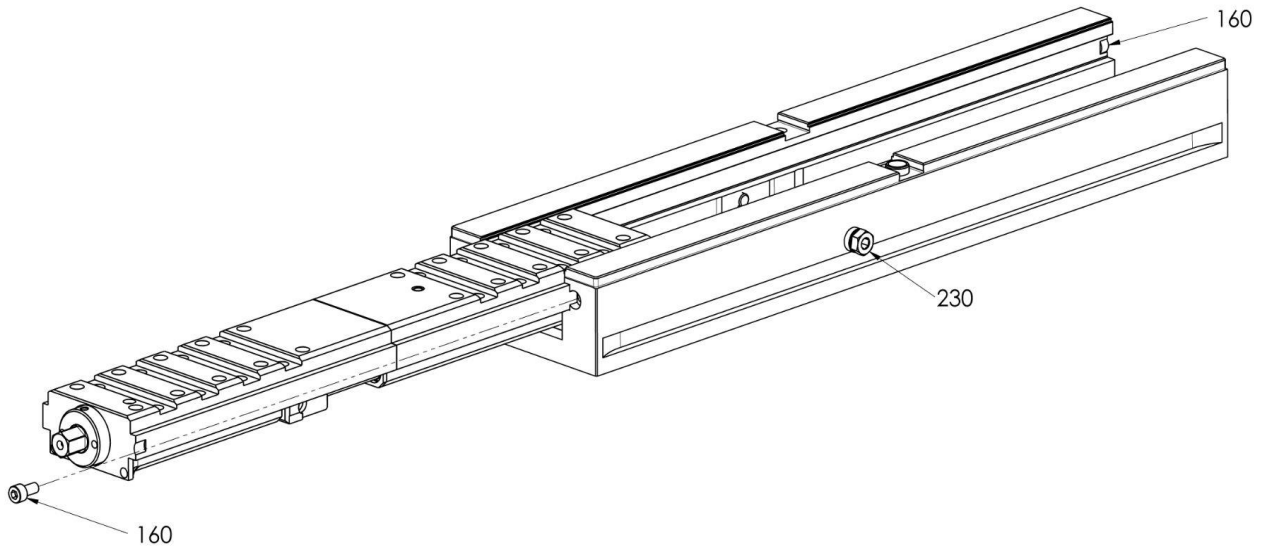

- Fully contract the carriage unit.
- Push the carriage unit into the guide until it comes into contact with the other component. The carriage unit is now positioned around 20 mm over the centre.

Important:

Carriage unit must not come into contact with the rear cylinder screw. (pos. 160)

- Fully tighten the clamping screw (pos. 230) and undo by ½ turn.
- Extend the carriage unit and check whether or not the cylinder screw (pos. 40) and the clamping screw (pos. 230) have correctly engaged in the clamping piece. (pos. 220).

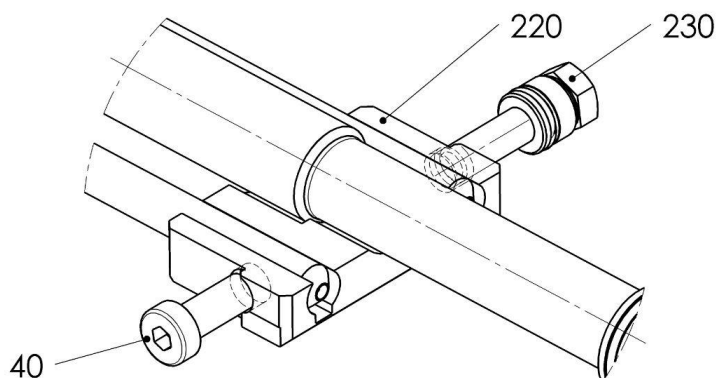

- Install the front cylinder screw. (pos. 160)
- Install the system jaws in the carriages and tightened the cylinder screw (12.9) with a torque of 60 Nm.

9 Assembly drawing

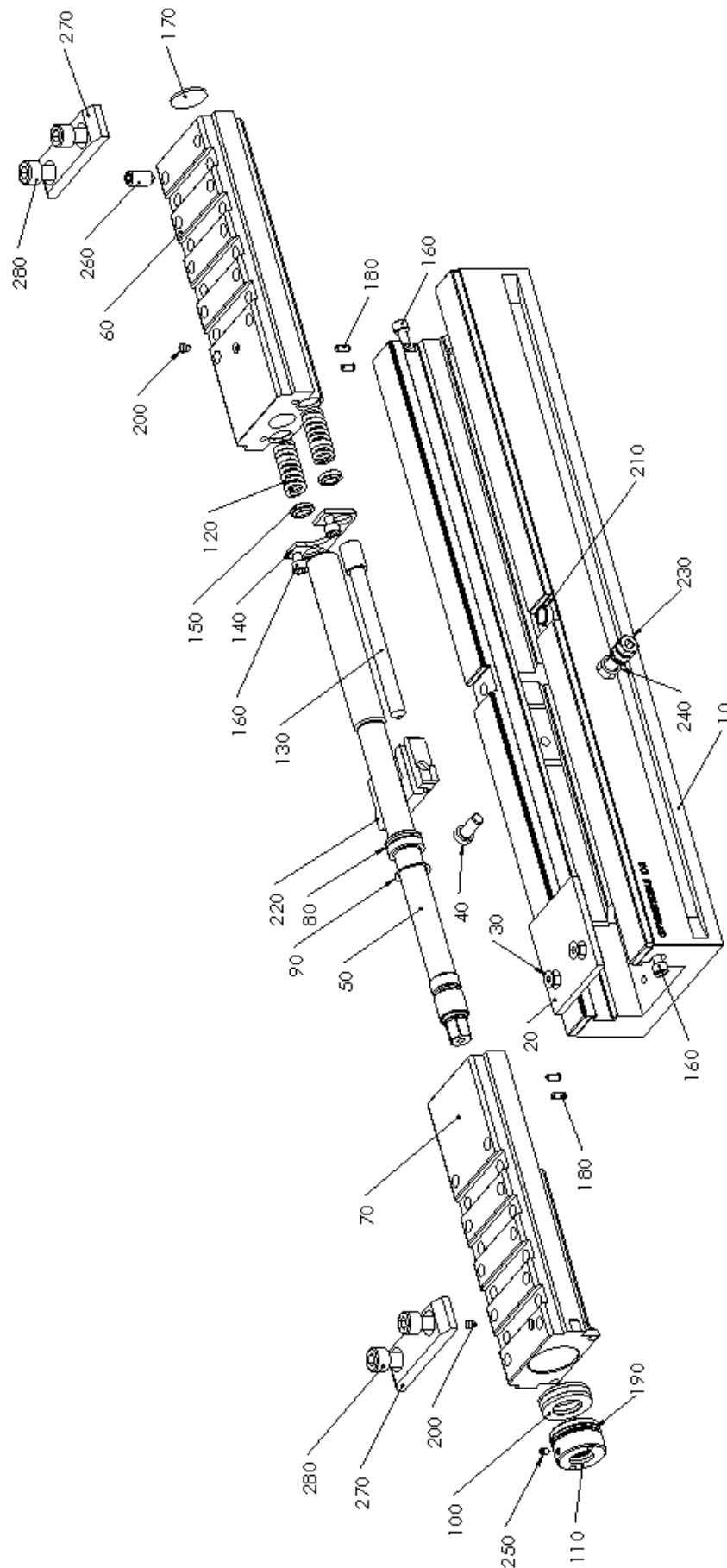

9.1 Parts list

Pos.	Part. No.	Designation	Quantity
10	DGM.125.501.82	L-320 base body	1
	DGM.125.511.82	L-390 base body	
	DGM.125.521.82	L-460 base body	
	DGM.125.531.82	L-530 base body	
	DGM.125.541.82	L-600 base body	
	DGM.125.551.82	L-670 base body	
	DGM.125.561.82	L-740 base body	
20	DGM.125.513.11	Plate	1
30	XNZ.10611.359	Countersunk screw M6x12	2
40	XNN.10360.413	Internal hexagon cylinder screw NK M8x20 10.9	1
50	DGM.125.504.11	L-320 threaded spindle	1
	DGM.125.514.11	L-390 threaded spindle	
	DGM.125.524.11	L-460 threaded spindle	
	DGM.125.534.11	L-530 threaded spindle	
	DGM.125.544.11	L-600 threaded spindle	
	DGM.125.554.11	L-670 threaded spindle	
	DGM.125.564.11	L-740 threaded spindle	
60	DGM.125.506.81	L-320 rear carriage	1
	DGM.125.516.81	L-390 rear carriage	
	DGM.125.526.81	L-460 rear carriage	
	DGM.125.536.81	L-530 rear carriage	
	DGM.125.546.81	L-600 rear carriage	
	DGM.125.556.81	L-670 rear carriage	
	DGM.125.566.81	L-740 rear carriage	
70	DGM.125.505.81	L-320 front carriage	1
	DGM.125.515.81	L-390 front carriage	
	DGM.125.525.81	L-460 front carriage	
	DGM.125.535.81	L-530 front carriage	
	DGM.125.545.81	L-600 front carriage	
	DGM.125.555.81	L-670 front carriage	
	DGM.125.565.81	L-740 front carriage	
80	XNN.61072.117	O-ring NBR21.95x1.78	1
90	DGM.125.517.11	Spring washer	1
100	XNN.20073.304	Axial cylindrical roller bearing 81104-TV	1
110	DGM.125.512.11	Adjusting nut	1
120	XNN.30030.006	Pressure spring 2.5x15x47.5	2
130	DGM.125.508.11	Ram	2
140	DGM.125.509.11	Retaining panel	1
150	XNN.65114.100	Scraper SA Ø10	2
160	XNN.10301.359	Internal hexagon cylinder screw M6x12	4
170	XNN.12620.250	Closing disc Ø25	1
180	XNN.90004.040	Spring-loaded pressure piece Ø4	8
190	XNN.63028.353	X-ring 28.17x3.53	1
200	XNN.90102.040	Grease nipple Ø4	2
210	DXM.100.010.11	Centring socket	1
220	DGM.125.507.11	Clamping piece	1
230	DGM.125.510.11	Clamping screw	1
240	XNN.61071.085	O-ring NBR/70 10.82x1.78	1
250	XNN.10706.306	Internal hexagon threaded pin SP M5x6	1

Pos.	Part. No.	Designation	Quantity
260	XNN.10706.520	Internal hexagon threaded pin SP M10x20	1
270	DGZ.125.063.11	Position bar	2
280	XNN.10311.463	Internal hexagon cylinder screw M10x20 12.9	4

Note:

Pos. 10, 60 and 70 cannot be supplied as individual spare parts as these are designed and fitted at the factory to work together.

Repairs can be provided by the manufacturer or an authorised service point.

Pos. 270 and 280 are only available for vises with length 530, 600, 670, 740 mm



10 Swivel and adapter plate

10.1 Function

Slanted and curved items can be securely clamped with 4-point clamping using the protected O-ring swivel plate system.

The swivel plate is pulled downwards during the clamping process due to its conical swivel plate bearings; this means that the swivel plate is not likely to lift off.

With the 6-fold reversible jaw it is possible to cover numerous clamping solutions in a straightforward way. A total of six different clamping sides are available, at the four sides of the jaw as well as at two places with a convex "grip" profile.

It is also possible to carry out two-sided processing using the tungsten carbide coated side of the 6-fold reversible jaw.

Processing the first side

For raw part clamping using the 6-fold reversible jaw, five different "grip" clamping sides are available with a clamping depth of 3, 8 and 18 mm.

Processing the second side

Clamping with the tungsten carbide coated side of the 6-fold reversible jaw.

It is important to take into account that during the first clamping process, the 6-fold reversible jaws can yield slightly until the play in the peg seating is eliminated.

The workpiece position must be measured; the zero point should not be determined until after 3 to 5 power clampings.

Handling the demounted swivel plate

The conical swivel peg can be pulled out since it is only held in position by an O-ring in the counter direction. When handling the swivel plate, it should not be turned upside down since this could cause the peg to fall out.



10.2 Servicing, cleaning, maintenance

The upper shoulder of the swivel peg must be oiled regularly.

In order to ensure that the areas under stress remain well lubricated, the swivel plate should be turned around its entire axis once a week so that the lubrication film can be renewed.

Lubrication of the entire peg is recommended once a year.

10.3 Troubleshooting, eliminating faults

Swivel plate is difficult to turn

- Disconnect the swivel plate and push the swivel peg from below out of the swivel plate.
- Check the vice guide and swivel plate surface for indentations or deformations. If necessary, re-grind the plate and the vice guide.
- Check the peg for soiling.
- Check that the O-rings are correctly positioned. The upper O-ring must make good contact.
- Lubricate the entire system with grease and reassemble.

10.4 Removing and replacing parts

- Release cylinder screws and remove the jaws.
- Clean and oil the contact surfaces, e.g. with MOTOREX Supergliss 68 K to ISO VG 68.
- Place the swivel- and adapter plate and tighten the cylinder screws to 60 Nm.

10.5 Fitting the 6-fold reversible jaws

- Determine the mounting positions of the 6-fold reversible jaws.
The best clamping results are achieved when clamping parts as far out as possible.
- Move the cover screws so that the selected clamping position is available.
- Position the 6-fold reversible jaws and loosely insert the cylinder screws.
- Turn the 6-fold reversible jaws to the required clamping surface and slightly pre-clamp the workpiece so that the clamping faces are parallel to the workpiece.
- Use a torque of 80 Nm to tighten the cylinder screws of the 6-fold reversible jaws.

Important:

When the clamping faces of the 6-fold reversible jaws are not aligned parallel to the workpiece surface it is possible that the 6-fold reversible jaw becomes loose through the clamping force.



11 Aluminium jaws

The aluminium jaws are designed for producing workpiece-specific clamping contours. In order to achieve maximum precision of the contour, it is recommended that the contour milling be carried out with pre-clamping of the aluminium jaws. For this purpose, a narrow spacer piece can be clamped at the bottom and the pre-clamped aluminium jaws can then be milled to achieve the desired clamping contour.

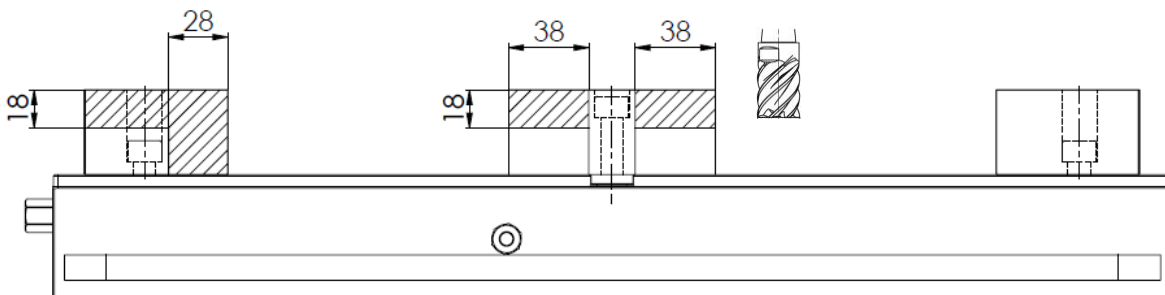

In view of the fact that clamping may be carried out in different ways, the setting-up technician is responsible for ensuring that adequate clamping cross sections exist and that the workpiece is safely clamped.



12 Fixed jaw vise

The double vise can be used also as a fixed jaw vise.

Remove the middle jaw, the clamping and cylinder screw (Pos. 230 and 40) and slide the carriage unit on the cylinder screw (Pos. 160).

To fix the carriage unit, the threaded pin (Pos. 260) must be clamped through the slider into the counterbore in the base body with 20 Nm.

A cover for the area of the disassembled middle jaw is not included in the standard scope of delivery of the double vise.

The disassembly to the double clamp is done in reverse order.



13 Positioning bar

For the lengths 530, 600, 670, 740 mm are two positioning bars (pos. 270) included in the scope of delivery, so that a lowering of the slide ends and thus not possible penetration of chips between the guide surfaces.

If the clamping range is small, we recommend mounting the positioning bars on the slide ends as support with the cylinder screws (pos. 280) and a tightening torque of 60 Nm.



14 Taking out of service

The clamping device and all accessories can be disposed of as scrap metal without any risk.



H.-D. Schunk GmbH & Co.
Spanntechnik KG
Lothringer Strasse 23
D-88512 Mengen

Tel.: +49-7572-7614-0
Fax: +49-7572-7614-1099

info@de.schunk.com
schunk.com