



Guidelines on the Declaration of Conformity

A conformity evaluation has been carried out for the product in terms of the EU Low Voltage Directive 2014/35/EU, the Electromagnetic Compatibility (EMC) Directive 2014/30/EU and RoHS 2011 / 65 / EU with 2015 / 863 EU.

The Declaration of Conformity is laid out in writing in a separate document and can be requested if required.

Guidelines on the EMC Directive (2014/30/EU)

The product cannot be operated independently according to the EMC Directive.

Only after integration of the product into an overall system can this be evaluated in terms of the EMC.

For electronic equipment, the evaluation has been verified for the individual product in laboratory conditions, but not in the overall system.

Guidelines on the EU Directive 2011 / 65 / EU (RoHS II) with 2015 / 863 EU (RoHS III - from 22 July 2019), which restrict the use of certain hazardous substances in electrical and electronic devices as well as in products / components (category 11), the proper operation of which is dependent on electric currents and electromagnetic fields.

Guidelines on the Machinery Directive (2006/42/EC)

The product is a component for installation into machines according to the Machinery Directive 2006/42/EC.

The product can fulfil the specifications for safety-related applications in coordination with other elements.

The type and scope of the required measures result from the machine risk analysis.

The product then becomes a machine component and the machine manufacturer assesses the conformity of the safety device to the directive. It is forbidden to start use of the product until you have ensured that the machine accords with the regulations stated in the directive.

Guidelines on the ATEX Directive

Without a conformity evaluation, this product is not suitable for use in areas where there is a high danger of explosion. For application of this product in areas where there is a high danger of explosion, it must be classified and marked according to Directive 2014/34/EU.

Guidelines on the REACH Regulation (EC No. 1907/2006)

of the European Parliament and of the Council Concerning the Registration, Evaluation, Authorisation and Restriction of Chemicals. This regulates the manufacture, placing on the market and use of chemical substances in preparations, under certain conditions also pertaining to substances in products. *mayr*® power transmission exclusively manufactures products articles: clutches/couplings, electric motors, brakes and the appropriate rectifiers) in accordance with the definition in Article 3 Section 3 of the REACH Regulation.

Safety and Guideline Signs

DANGER



Immediate and impending danger, which can lead to severe physical injuries or to death.

CAUTION



Danger of injury to personnel and damage to machines.



Guidelines on important points

General Safety Guidelines

DANGER



Danger of death! Do not touch voltage-carrying lines and components.

DANGER



Danger of burns when touching hot surfaces.

CAUTION



- Danger of device failures caused by short-circuits and earth short-circuits at the terminals
- Electronic devices cannot be guaranteed fail-safe.

During the risk assessment required when designing the machine or system, the dangers involved must be evaluated and removed by taking appropriate protective measures.

To prevent injury or damage, only professionals and specialists are allowed to work on the devices. They must be familiar with the dimensioning, transport, installation, initial operation, maintenance and disposal according to the relevant standards and regulations.

General Safety Guidelines



Only carry out installation, maintenance and repairs in a de-energised, disengaged state and secure the system against inadvertent switch-on.



Before product installation and initial operation, please read the Installation and Operational Instructions carefully and observe the Safety Regulations. Incorrect operation can cause injury or damage.

Installation and Operational Instructions for ROBA®-brake-checker plus DC Type 028.600.2

(B.0286002.EN)

Application

ROBA®-brake-checker plus DC monitoring modules are used to supply permitted ROBA®-stop safety brakes. Motion monitoring of the armature disk for released ROBA-stop® safety brakes is possible.

Monitoring module ROBA®-brake-checker DC

- Consumer operation with overexcitation and/or power reduction
- Controlled output voltage (on reduction)
- Automatic reduction to holding voltage U_H
- Fast or slow disconnection
- Armature disk motion recognition (release and drop-out recognition)
- Preventative function monitoring (wear recognition and error recognition, functional reserve)
- Continuous drop-out recognition
- Maximum output current $I_{RMS} = 5 \text{ A}$
- Maximum overexcitation current $I_o = 16 \text{ A}$
- Safe monitoring of the switching times (optional)

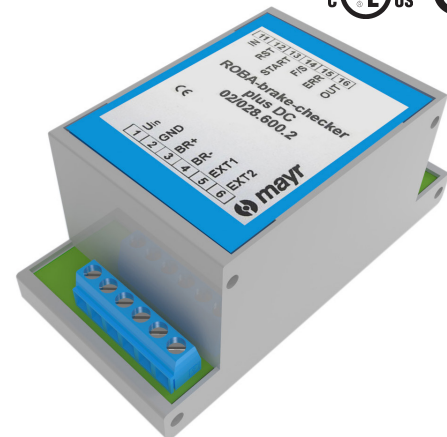

UL information applies only when the UL mark is printed onto the product label.

Dimensions (mm)

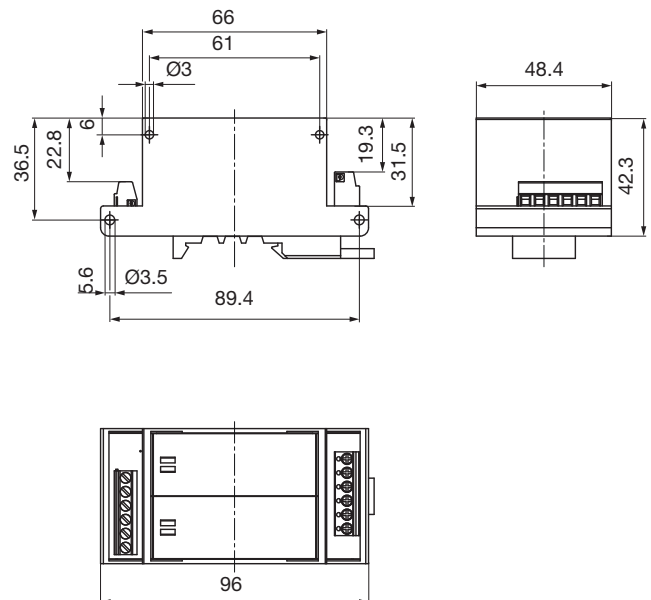

CAUTION



The ROBA®-brake-checker with integrated DC-side disconnection is not suitable for being the only safety disconnection in applications!

Function

The ROBA®-brake-checker plus DC monitoring module is intended for use with an input voltage of 24 VDC. The monitoring module monitors the movement of the armature disk and emits the determined switching condition via control terminal (signal output).

Critical conditions (line breakages, wear, excess temperature) can be recognised and the respective signal can be emitted via control terminal (error output).

It is possible to select between fast and slow disconnection via the input F/S on the control terminal.







Louder switching noises are generated on the brakes in case of fast switch-off than in case of slow switch-off.

The movement detection feature of the armature disk is based on the detection of electromagnetic changes in the brake. If, due to unfavourable external influences, the secured detection cannot be ensured, it is possible that the signal and error outputs do not correspond to the expected state (plausibility).



The use of the ROBA®-brake-checker in combination with brakes of other manufacturers is not intended and expressly not approved by *mayr*® power transmission.

In these cases, operation is at your own risk, the guarantee and service and support provided by *mayr*® power transmission no longer apply.

Technical data				
Supply voltage Power terminal	SELV/PELV ripple content ≤ 5 %	U_i	[VDC]	24 (18 - 32)
Output voltage	± 5 %	U_o	[VDC]	$0.99 \times U_i$
		U_H	[VDC]	4, 6, 8, 12, 16, 20, 24
Output current	at ≤45 °C	I_{RMS}	[A]	5
	at ≤60 °C	I_{RMS}	[A]	2.5 
	at ≤70 °C	I_{RMS}	[A]	2.5 
Power dissipation			[W]	<3
Device fuses				$1.2 * I_o$, fast acting or circuit breaker 6 A; characteristic Z/A
Protection				IP20 terminals
Control terminal				Nominal cross-section 0.14 - 1.5 mm ² (AWG 26 -16), max. tightening torque for screws: 0.4 Nm / 3.6 lb-in
Power terminal				Nominal cross-section 0.2 - 1.5 mm ² (AWG 22 -14), max. tightening torque for screws: 0.4 Nm / 3.5 lb-in
Device ambient temperature			[°C]	 -25 to +70 / -25 to +60 
Storage temperature			[°C]	-40 to +105
Conformity markings				 
Protection				IP20
Installation conditions				The installation position can be user-defined. Please ensure sufficient heat dissipation and air convection! Do not install near to sources of intense heat!

Type	Input voltage ±5 % [VDC]	Output voltage ±5 %		Article number
		U_o [VDC]	U_H [VDC]	
028.600.2	24	$0.99 \times U_i$	4	8262586
			12	8267308
			16	8267387

Preventative function monitoring

Through the monitoring of different parameters, the ROBA®-brake-checker recognises safety critical operating conditions of the brake in advance, as well as acute faults (e.g. line breakage). These are determined as they occur and are notified to the user as a warning before the brake can no longer be operated.

Only the mechanical switching function is checked. Conclusions on the braking torque are not possible (e.g. reduced friction value due to oiling of the brake lining)

Possible causes for the warning:

- Increasing wear
- Rising coil temperature
- Falling supply voltage
- Line voltage drop on feed lines to the brake

Electrical connection

Power terminal

1	Supply voltage +24 VDC
2	Supply voltage 0 VDC
3	Output voltage +
4	Output voltage -
5	Contact 1 (External fast switch off)
6	Contact 2 (External fast switch off)

Electrical connection

Control terminal

11	IN Mode (Input)	IN
12	Reset (Input)	RST
13	Start (input)	START
14	Fast/slow (Input)	F/S
15	Error (output) max. 100 mA	ERR
16	Signal (output) max. 100 mA	OUT

Wiring Example

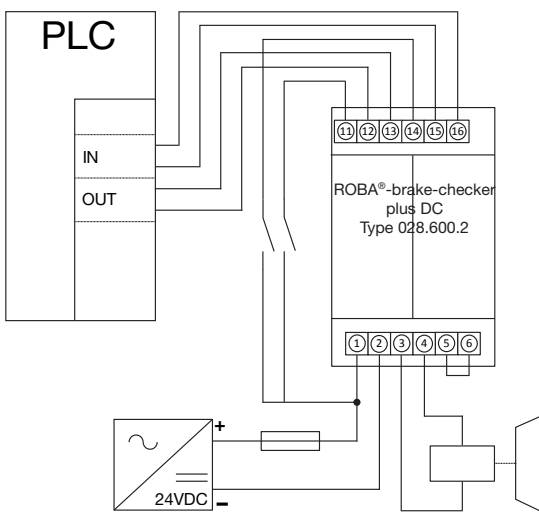

Wiring Example

(external fast switch off)

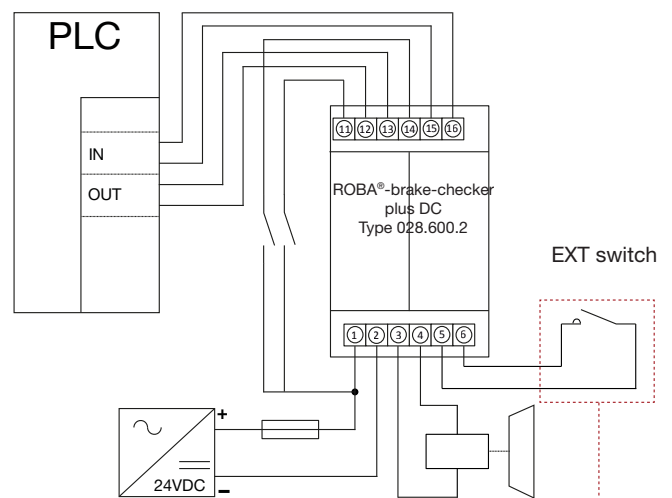

Equivalent circuit diagram

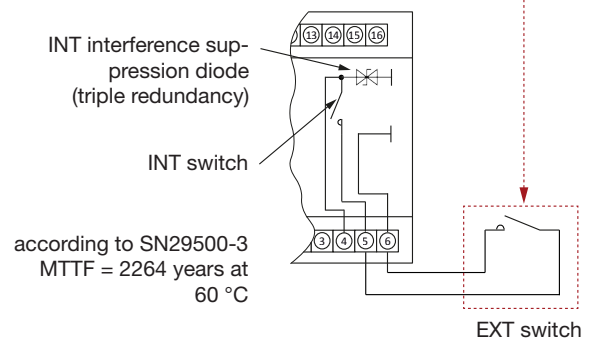

Inputs

F/S	14	0 VDC (low)	Slow switch off (SLOW)
		24 VDC (high)	Fast switch off (FAST)
START	13	0 VDC (low)	Brake is not energised
		24 VDC (high)	Brake is energised
IN	11	0 VDC (low)	Armature disk condition recognition activated
		24 VDC (high)	Armature disk condition recognition deactivated
RST	12	0 VDC (low)	Deactivated
		24 VDC (high)	Activated

On activating the reset procedure, the ROBA®-brakechecker restarts, and as a result, all pending signals (ERROR) are deleted.

$t_B = 200$ ms (Boot time)
 $t_C = 400$ ms (Calibration time)
 $t_R = 600$ ms (Reset time)
 $t_p = 10 < 100$ ms (Pulse time → must be less than 100 ms, greater than 10 ms)



- All inputs without assignment (not connected) have the condition **0 VDC (low)**.
- All inputs 24 VDC (high) have a current consumption of approx. 825 μ A.

Outputs

OUT	16	0 VDC (low)	Brake is not energised, movement of the armature disk for closing the brake.
		$0.99 \times U_I$ (high)	Brake energised, movement of the armature disk for opening the brake.
ERR	15	$0.99 \times U_I$ (high)	no errors
		0 VDC (low)	Brake does not open or close, line interruption, false detection
Warning ¹⁾			Preventative function monitoring (Wear recognition and error recognition)

1) Rectangular signal 10 Hz

Functional Guidelines

Start process

During each individual start process, all outputs (signal, error, warning) are reset.

The outputs must be assessed for the plausibility of signal conditions, signal changes and their correct temporal sequence.

Inching Mode

During inching mode (fast sequence of switching on and off), no reliable detection is possible.

After the end of inching mode, restart the monitoring function:

- De-energise the brake
- Switch on (energise) the brake again

Repeated switch-on (energisation) before the brake is closed generates a fault when the maximum current is reached.

Voltage reduction mechanism

After a brake-specific overexcitation time period, the intelligent voltage reduction mechanism mode adjusts to the pre-set holding voltage. Manual adjustment of the overexcitation time is not necessary.

Release Monitoring

The release monitoring recognises the movement of the armature disk for opening the brake after switch-on as well as the movement of the armature disk for closing the brake after switch-off.

The release monitoring can be deactivated for certain applications in order to prevent errors.

Possible applications:

- Parallel operation of several brakes
- Damped brakes
- Unspecific brakes

Switch-ON

Brake switch-on occurs with a connected supply voltage (control and power terminal) by closing start (Input) on the signal side using the voltage 24 VDC or a 24 VDC control signal applied there. A green light-emitting diode emits a signal when the device is switched on. After the changeover from overexcitation voltage to holding voltage, the diode continues to illuminate at reduced brightness.

Switch-OFF

Fast switch-off

If short engagement times are desired, fast switching should be used (FAST).

Here, the ROBA®-brake-checker monitoring module limits the switch-off voltage to approx. 60 VDC.

DC-side disconnection is signaled by the red light-emitting diode flashing at the moment of switch-off.

Optional (customer-side) External fast switch off

A single-pole energy separation can be achieved by means of an external switch contact (see wiring example) (tried and tested principle according to ISO 13849-2). Depending on the required PL and category, the control element may have to be designed redundantly in accordance with ISO 13849-1.

Failure detection and corresponding diagnostic coverage (ISO 13849-1) can be achieved by the following design of the external switch:

- Feedback with positively driven contacts
- Mirror contacts

The monitoring functions are retained!

Series connection of the isolating contacts at a contact opening of $\geq 3\text{mm}$ increases reliability and lifetime.

Slow switch-off

If longer engagement times or **quieter switching noises** are desired, slow switching should be used (SLOW) (factory setting).

Continuous drop-out recognition

The continuous drop-out recognition can detect the following situation and signal it via the outputs:

Brake is energised --> Undesired movement of the armature disk for closing the brake (drop-out of the armature disk).

Changes of the output signals:

Control terminal 16:	OUT ($0.99 \times U_i$)	--> 0 VDC
Control terminal 15:	ERR ($0.99 \times U_i$)	--> 0 VDC

Possible Causes

- Excessive temperature
- Marginal dimensioning
- Mechanical influences

Reliability Nominal Values

MTTF	160 years at 60 °C
	250 years at 40 °C
Duration of use	20 years

The basis of the MTTF calculation forms (if available) the information of the component manufacturer supplemented by the information from the Siemens standard SN 29500. For the calculation, a simplified Parts-Count procedure has been used (EN ISO 13849-1)

Time Delays

Delays may occur during the detection and processing of various brake conditions, input and output signals.

Switch-on delay	Normal operation	≤ 4 ms
	Malfunction	≤ 4 ms
Delay time		≤ 4 ms
Signal delay		≤ 20 ms

Switching Times

For ROBA®-linearstop electromagnetic type 382 size 10, 20 an adapted ROBA®-brake-checker plus DC (article number 8288568) is used.

- The switching time t_2 of the brake can increase up to 60 ms.

EMC-compatible Installation



- Avoid antennae effects: Keep the supply cables as short as possible; do not form rings or loops with the cables!
- Mount good earth connections onto the metal body of the brake.
- Lay control cables (total length <30 m) separately from power cables or from strongly pulsating supply cables!
- A voltage drop can occur when operating using long lines.
 - ▶ Check the holding voltage on the respective brake.

Cycle frequency

In order to prevent thermal overload, an upper cycle limit must be observed for especially high-performance brakes in operation with fast switch-off.

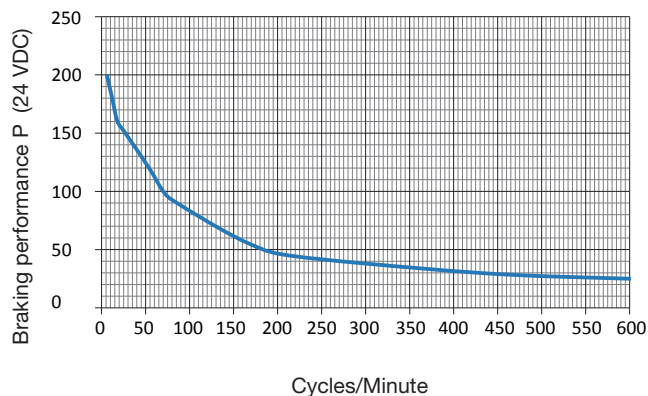

For brakes, which do not require overexcitation, the holding voltage may be lower than the nominal voltage, e.g. on power reduction to reduce the coil temperature.

Intended Use

ROBA®-brake-checker products have been developed, manufactured and tested as electronic equipment in compliance with the DIN EN 61000 standard and in accordance with the EMC directive. During installation, operation and maintenance of the product, the requirements for the standard must be observed. ROBA®-brake-checker products are for use in machines, systems and devices and must only be used in the situations for which they are ordered and confirmed. The products are designed for installation into electrical control cabinets and terminal boxes. Using them for any other purpose is not allowed.

Device Fuses

Installation of a device fuse into the supply voltage line of the ROBA®-brake-checker monitoring module.

Short-circuits or earth short-circuits can lead to ROBA®-brake-checker monitoring module failures. After fuse elements have reacted to a malfunction, the ROBA®-brake-checker monitoring module must be checked for functional and operational safety (overexcitation voltage, switch-off voltage, response delay time, holding voltage). The same also applies after the magnetic coil of the brake has failed.



If the switching frequency is higher than 1 cycle per minute or if the overexcitation time t_o is longer than double the separation time t_2 , please observe the following:

$$P \leq P_N$$

The coil capacity P must not be larger than P_N or the nominal current I which flows through the ROBA®-brake-checker monitoring module must not be exceeded, otherwise the coil and the ROBA®-brake-checker monitoring module may fail due to thermal overload.

Time Diagram:

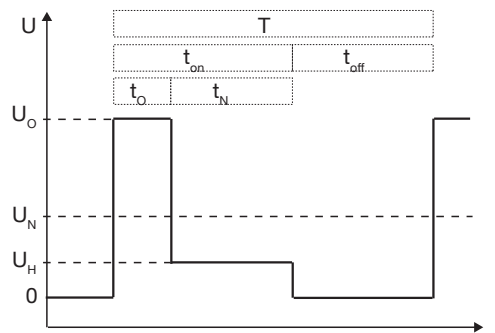

Calculations:

P [W] RMS coil capacity dependent on switching frequency, overexcitation and duty cycle

$$P = \frac{P_o \times t_o + P_N \times t_N}{T}$$

P_N [W] Coil nominal capacity (catalogue values, Type tag)

P_o [W] Coil capacity on overexcitation

$$P_o = \left(\frac{U_o}{U_N} \right)^2 \times P_N$$

P_H [W] Coil capacity at power reduction

$$P_H = \left(\frac{U_H}{U_N} \right)^2 \times P_N$$

t_o [s] Overexcitation time

t_H [s] Time of operation with reduction in capacity

t_N [s] Time of operation with coil nominal voltage

t_{off} [s] Time without voltage

t_{on} [s] Time with voltage

T [s] Total time ($t_o + t_N + t_{off}$)

U_o [V] Overexcitation voltage

U_H [V] holding voltage

U_N [V] Coil nominal voltage

I [V] RMS current dependent on switching frequency, overexcitation time and duty cycle

$$I = \sqrt{\frac{P \times P_N}{U_N^2}}$$

Functional sequence diagram

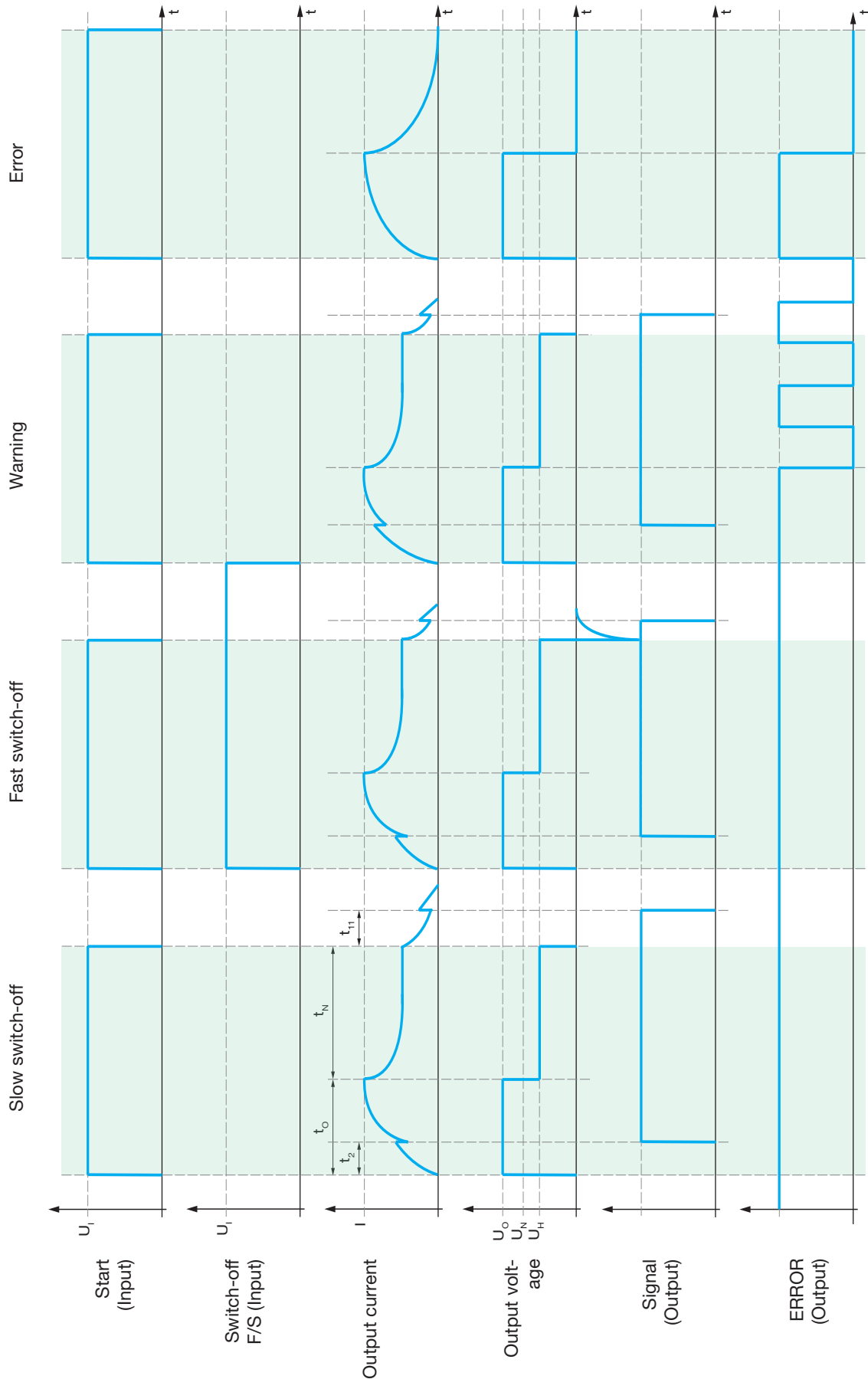

Installation and Operational Instructions for ROBA®-brake-checker plus DC Type 028.600.2

(B.0286002.EN)

Standards

Standards

VDE 0160/DIN EN 50178:1998-04

Electronic equipment for use in power installations

EMC inspections

EN 61000-6-2:2006-03

Interference immunity

EN 61000-6-4:2007-09

Interference emission

EN 61000-6-3:2011-09

Interference emission for living area

Insulation coordination

acc. VDE 0110 / EN 60664:2008-01

Pollution degree 2

Rated insulation voltage 63 VDC

Reliability nominal values

SN 29500, T = 60 °C / failure rates, components

EN ISO 13849-1

Guidelines on the WEEE Directive 2012 / 96 / EU

Avoidance of waste from electrical and electronic devices and the reduction of such waste through recycling.

Our electromagnetic products (ROBA-stop® / ROBA-quick® / ROBATIC®clutches) as well as the components required for control and monitoring (rectifier / brake-checker) and the DC motors (tendo®-PM) are frequently used in electrical and electronic devices within the appropriate area of application of WEEE, independent of the applicable product categories. The stated products do not fall within the area of application of this Directive.

They have been classified as electromagnetic / electronic components (VDE 0580) or as electronic equipment (EN 50178), and have been determined for installation in devices for "use in accordance with the intended purpose". Only products which are to be viewed as devices in terms of the Directive and not as parts or components are subject to registration obligations.

Disposal

Electronic Components

Products which have not been disassembled can be disposed of under Code No. 160214 (mixed materials) or components under Code No. 160216 (Code No. acc. 200/532/EC), or can be disposed of by a certified disposal firm.

Malfunctions / Breakdowns

Malfunction	Possible Causes	Measures
Brake does not release	No supply voltage available	Check voltage on input terminal
	Brake line interrupted	Check brake supply line (check passage)
	Line voltage drop on long line	Check the brake voltage
	Air gap not okay	Open and clean the brake, check the air gap. If possible, adjust the air gap.
No signal	Brake is not permitted	Use released brake
	Brake is worn	Open and clean the brake, check the air gap; replace the brake if necessary
	Incorrect input voltage polarity	Check input voltage and rotate if necessary
Error (continuous signal)	Brake release is not recognised	Check: Brake is not permitted Incorrect monitoring module (brake nominal voltage)
	Brake drop-out is not detected	Brake is not permitted Check the function of the monitoring module
	Break voltage drop	Check network stability and reinstate it
	Unit temperature over 90 °C	Check ambient temperature and, if necessary, improve the cooling.
Warning	Coil temperature of the brake too high	Check effective coil power, ext. Temperature, friction power
	Wear	Replace rotor
	Supply voltage too low	Check and, if necessary, increase supply/output voltage of the monitoring module; check line length
	Clock frequency or P_N (coil nominal capacity) too high	Lower clock frequency or P_N (coil nominal capacity)
	Unit temperature over 85 °C	Check ambient temperature. Check clock frequency and P_N .