



Reducing set-up times

Solutions for automated loading and unloading

Superior Clamping and Gripping



Automation of machine tools

- ✓ Increasing machine running times
- ✓ Increasing production efficiency
- ✓ Decreasing of unit costs
- ✓ Increasing the competitiveness
- ✓ Increasing the quality



Flexibilization of your production

- Automation through machine self-service

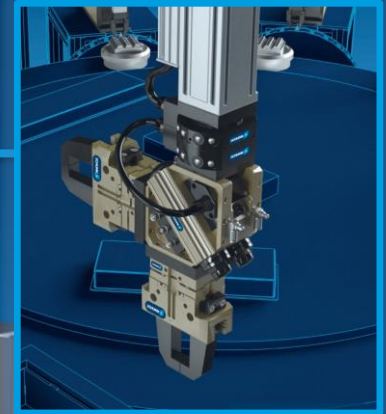

- Loading and unloading of workpieces



- Retrofittable automation



- Productivity through automated change of clamping devices

Flexibilization of your production

- Automation through machine self-service

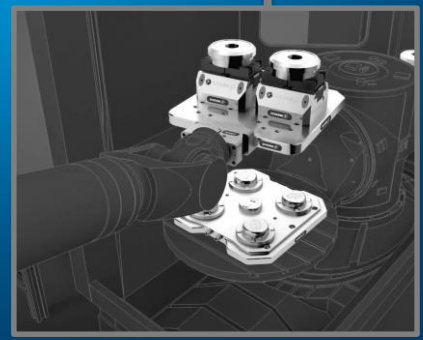
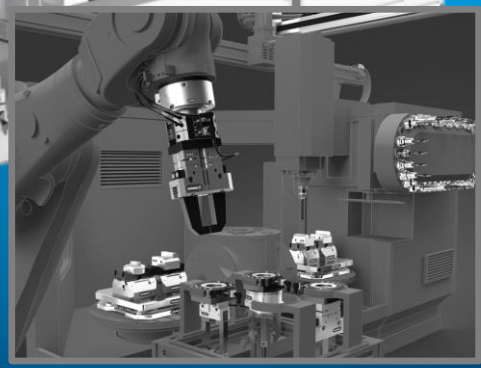
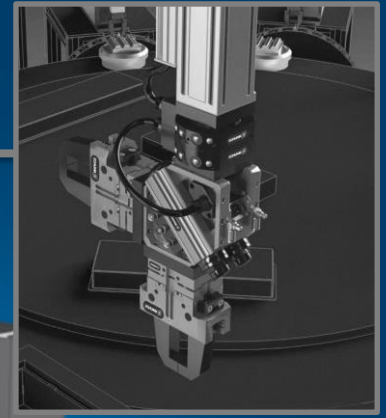

SCHUNK Lean Automation

Simple and efficient automation of existing machine tools

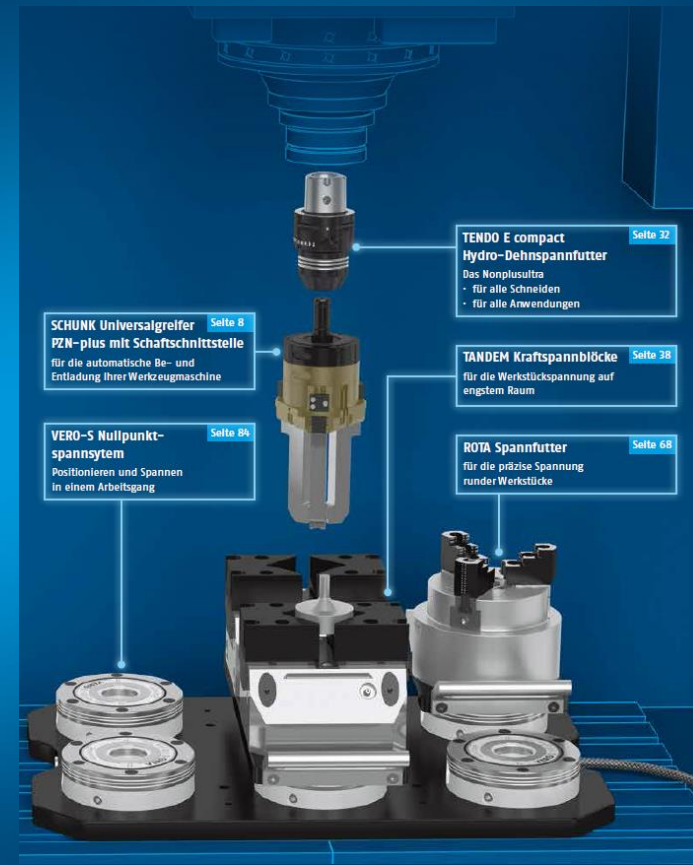
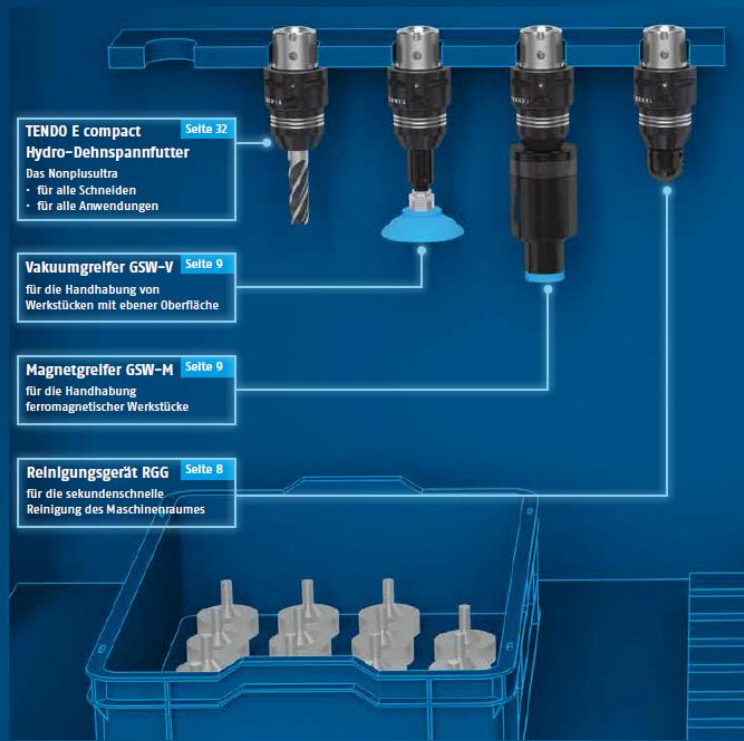

SCHUNK Lean Automation

Tools optimized for automation with a shank interface for use in combination with tool holders

- ✓ Independent workpiece change through machine spindle
- ✓ Minimization of set-up times
- ✓ Increasing of the machine efficiency

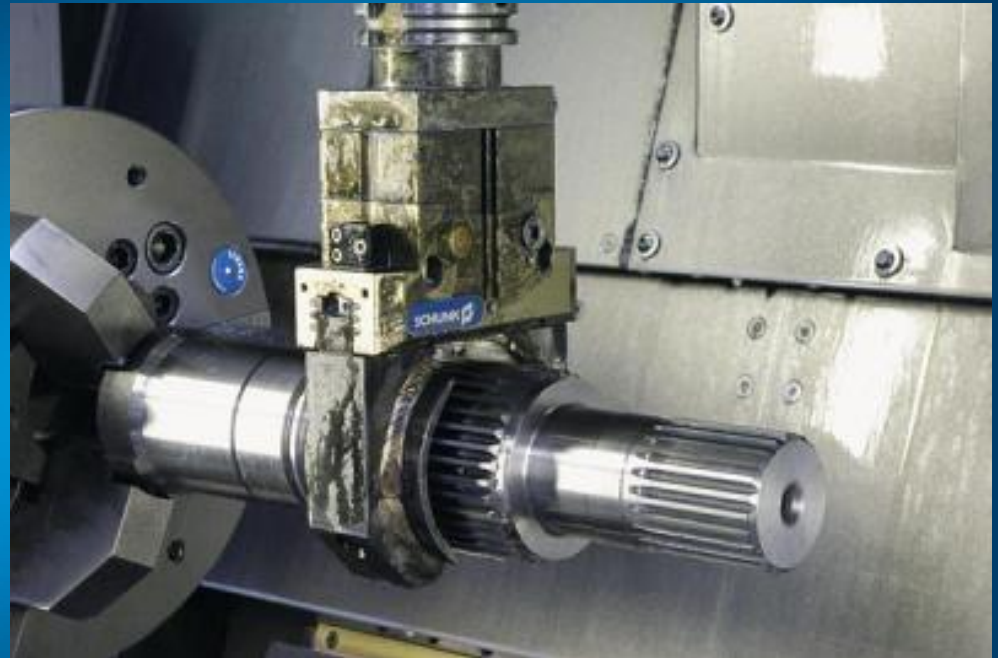

Flexibilization of your production

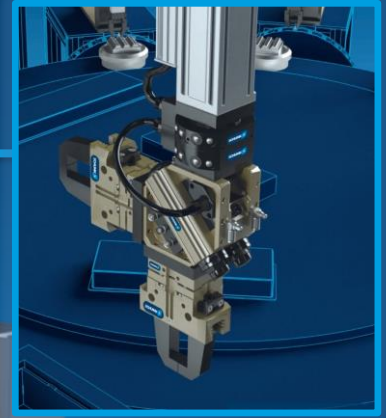

- Loading and unloading of workpieces

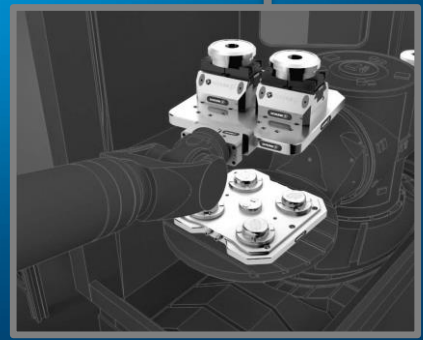
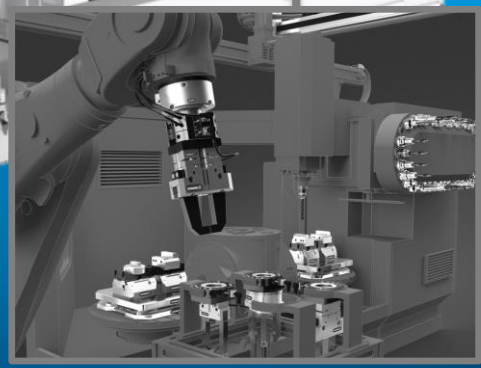

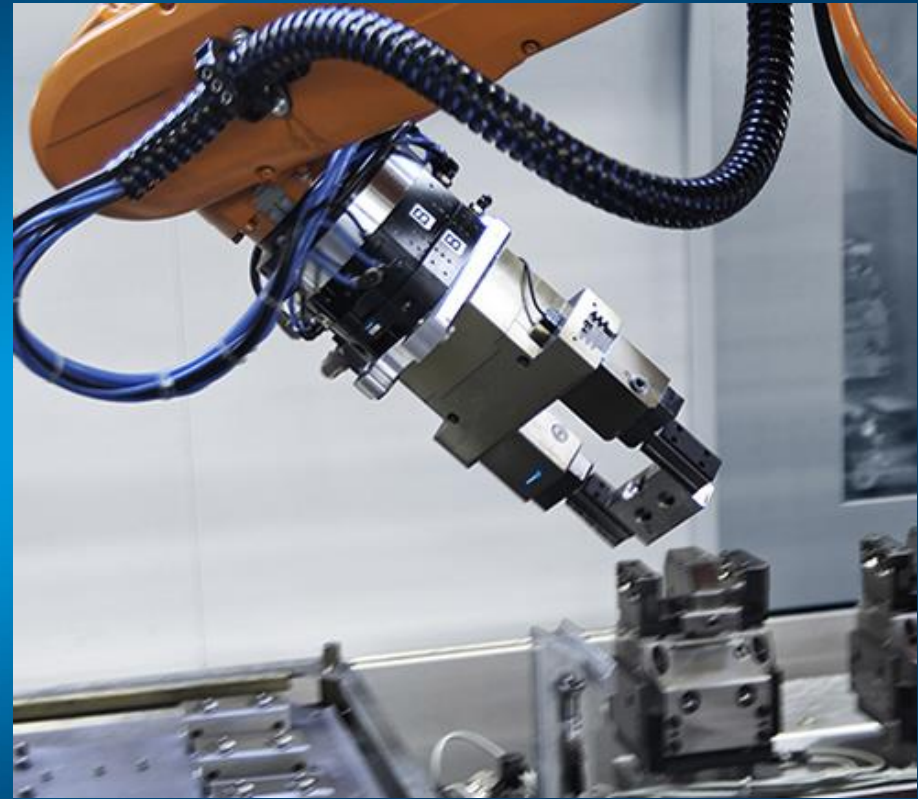

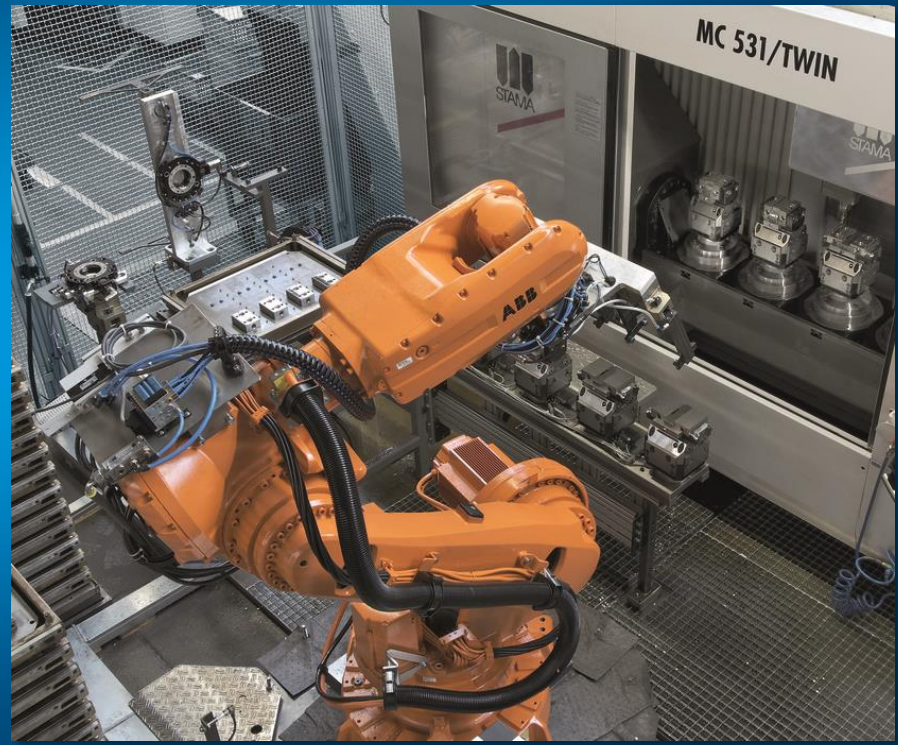
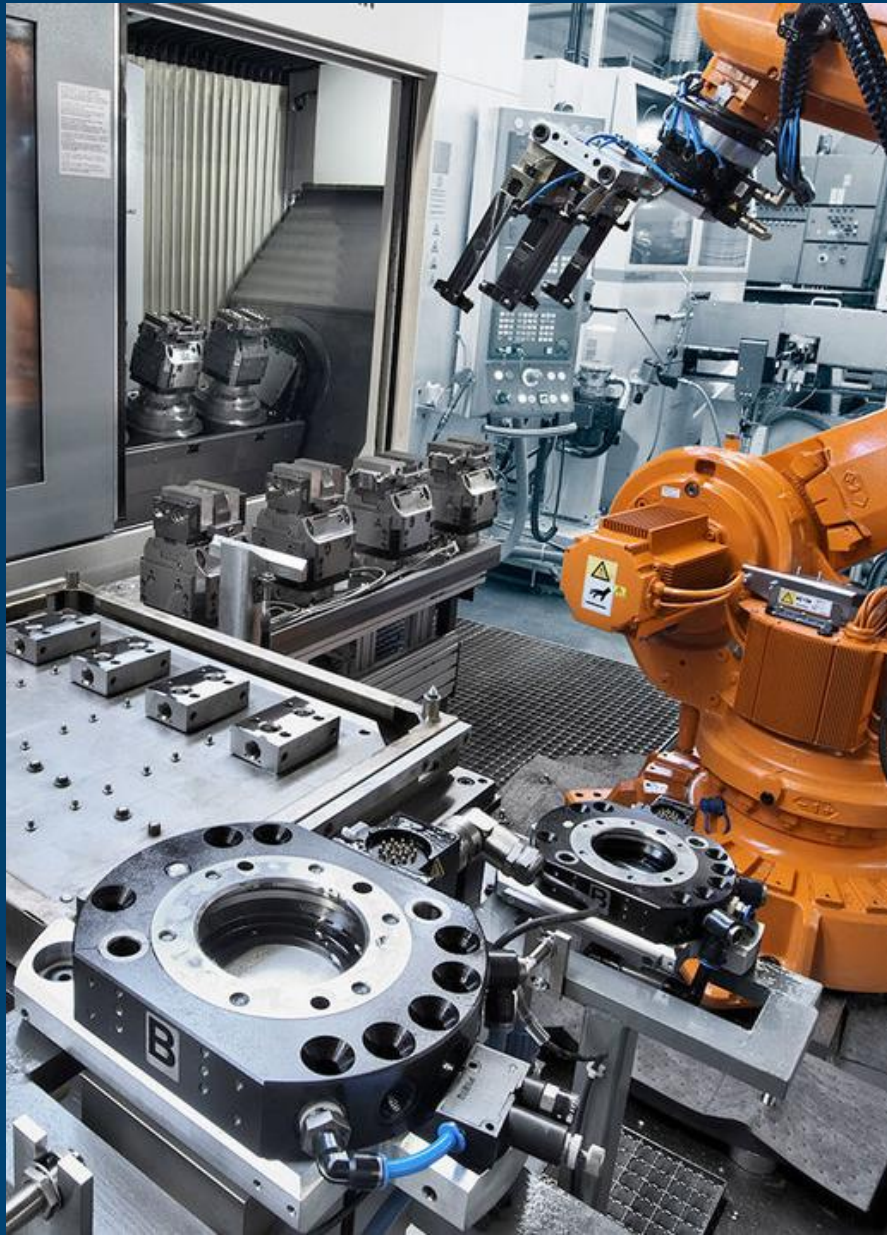

Flexibilization of your production

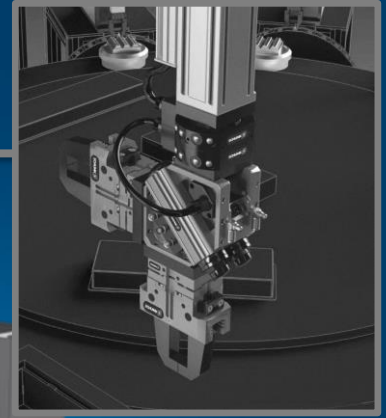
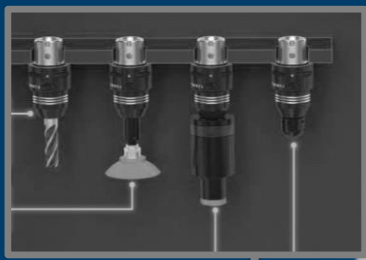

- Retrofittable automation

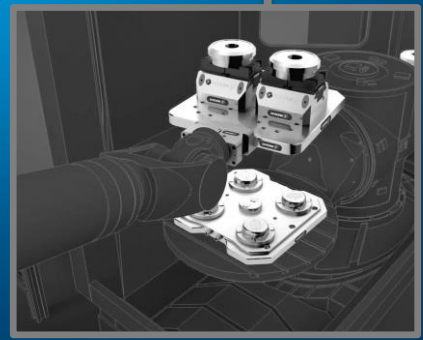

Flexibilization of your production

Retrofittable automation

- ✓ Simple solutions for loading and unloading
- ✓ For existing machine tools
- ✓ Easy handling and programming
- ✓ Safety technologies for safe working





Flexibilization of your production

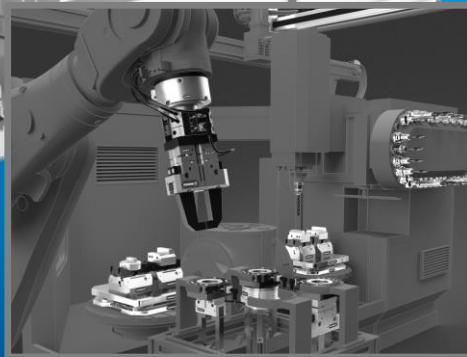
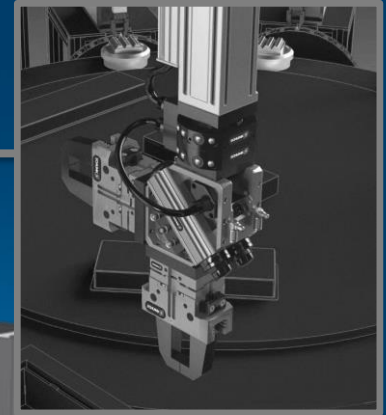

- Productivity through automated change of clamping devices

Productivity through pallet system

Retrofittable automation

- ✓ Quick-change pallet system for automated change of clamping devices
- ✓ Decreasing of set-up times

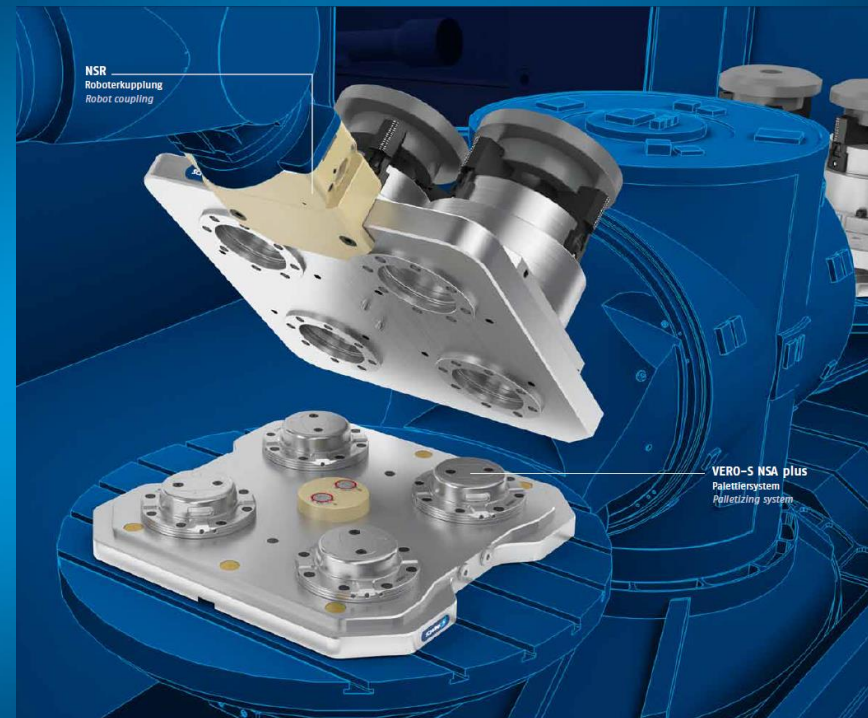

Productivity through pallet system

Quick-change pallet system to add the value of your machine tool

- ✓ High power density
- ✓ Low design
- ✓ Easy, fast and precise

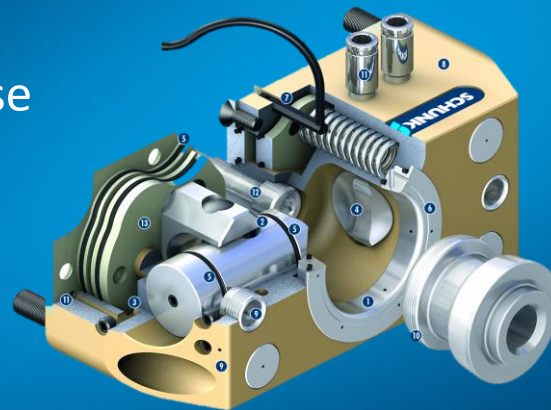

Superior Clamping and Gripping

SCHUNK ®

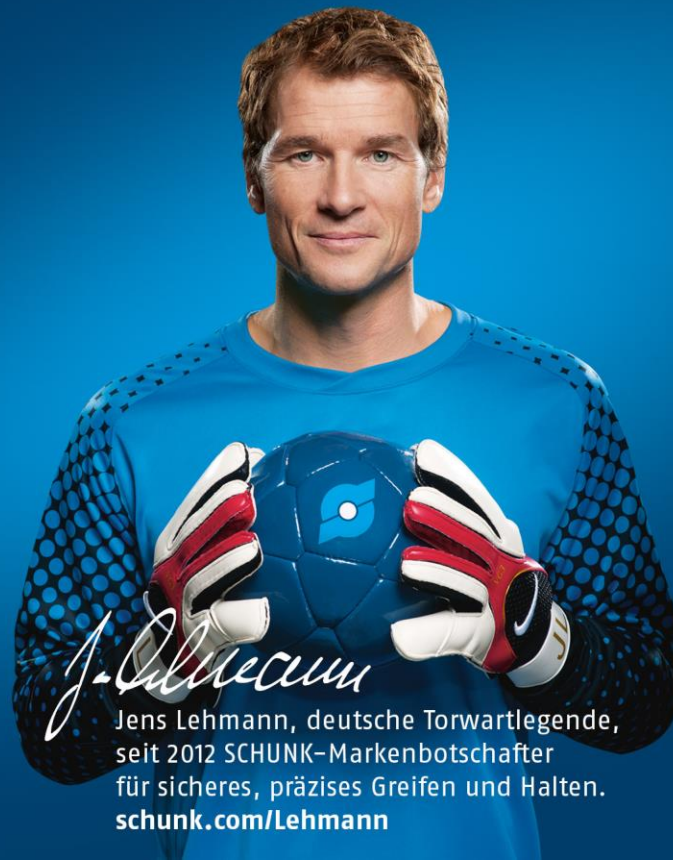

J. Lehmann

Jens Lehmann, deutsche Torwartlegende,
seit 2012 SCHUNK-Markenbotschafter
für sicheres, präzises Greifen und Halten.
schunk.com/Lehmann

