



Assembly and Operating Manual

EGI

Gripper for small components

Translation of Original Operating
Manual

Hand in hand for tomorrow

Imprint

Copyright:

This manual is protected by copyright. The author is SCHUNK SE & Co. KG.
All rights reserved.

Technical changes:

We reserve the right to make alterations for the purpose of technical improvement.

Document number: 1396645

Version: 11.00 | 11/10/2023 | en

Dear Customer,

Thank you for trusting our products and our family-owned company, the leading technology supplier of robots and production machines.

Our team is always available to answer any questions on this product and other solutions. Ask us questions and challenge us. We will find a solution!

Best regards,

Your SCHUNK team

Customer Management

Tel. +49-7133-103-2503

Fax +49-7133-103-2189

cmg@de.schunk.com



Please read the operating manual in full and keep it close to the product.

Table of Contents

1 General	6
1.1 About this manual.....	6
1.1.1 Presentation of Warning Labels	6
1.1.2 Definition of Terms	7
1.1.3 Symbol definition.....	7
1.1.4 Brands	7
1.1.5 Applicable documents	7
1.1.6 Sizes.....	7
1.1.7 Variants	7
1.2 Warranty	8
1.3 Scope of delivery.....	8
1.4 Accessories	9
2 Basic safety notes	10
2.1 Intended use.....	10
2.2 Constructional changes.....	10
2.3 Spare parts	10
2.4 Gripper fingers	11
2.5 Ambient conditions and operating conditions	11
2.5.1 Environmental conditions	11
2.5.2 Insulation resistance and voltage resistance in accordance with EN 60204-1	12
2.6 Personnel qualification	13
2.7 Personal protective equipment	14
2.8 Notes on safe operation.....	14
2.9 Transport.....	15
2.10 Malfunctions	15
2.11 Disposal	15
2.12 Fundamental dangers	16
2.12.1 Protection during handling and assembly	16
2.12.2 Protection during commissioning and operation	17
2.12.3 Protection against dangerous movements	17
2.12.4 Protection against electric shock.....	18
2.12.5 Protection against magnetic and electromagnetic fields	19
2.13 Notes on particular risks	20
3 Technical data	22
3.1 Name plate	22
3.2 Basic data	23
3.3 Diagrams.....	24

4 Design and description	26
4.1 Design	26
4.2 Description	26
4.3 Functional principle.....	27
4.4 Displays and control elements	28
4.4.1 LED status display PROFINET	28
4.4.2 LED status display EtherNet/IP™	29
4.4.3 LED status display EtherCAT	31
4.4.4 Service interface	33
4.5 Types of communication of PROFINET	33
4.6 Communication types of EtherNet/IP™	34
4.7 Communication types of EtherCAT	34
5 Assembly and settings	35
5.1 Assembling and connecting.....	35
5.2 Mechanical connection.....	36
5.3 Electrical connection	39
5.3.1 Pin allocation.....	40
5.3.2 Cable connections	42
5.3.3 Wiring diagram.....	43
5.3.4 External protection	43
5.3.5 Connecting the ground cable (functional ground).....	44
5.4 Combining multiple products.....	45
6 Start-up	46
6.1 Preparing commissioning with the web application.....	46
6.2 Commissioning the product.....	48
6.3 Operating behavior of the product	50
7 Troubleshooting.....	51
7.1 Communication malfunction.....	51
7.2 Product moves in a jerky fashion, is sluggish or blocked	51
7.3 Product does not open	52
8 Maintenance	53
8.1 Maintenance intervals.....	53
8.2 Lubricants and lubricating points	53
8.3 Disassembly and assembling	53
9 EU-Declaration of Conformity	54
10 Translation of the original declaration of incorporation	55
11 UKCA declaration of Conformity	56
12 UKCA declaration of incorporation	57

13 Information on the RoHS Directive, REACH Regulation and Substances of Very High Concern (SVHC) 58

14 Appendix 59

14.1 Commissioning with Siemens "TIA Portal" software for PROFINET 59

14.2 Commissioning with Rockwell "Studio 5000 ®" software for EtherNet/IP™ 64

14.3 Commissioning with Beckhoff "TwinCAT 3 ®" software for EtherCAT 72

14.4 Download the Anybus-IP Config tool 78

1 General

1.1 About this manual

This manual contains important information for a safe and appropriate use of the product.

This manual is an integral part of the product and must be kept accessible for the personnel at all times.

Before starting work, the personnel must have read and understood this operating manual. Prerequisite for safe working is the observance of all safety instructions in this manual.

In addition to these instructions, the documents listed under ▶ 1.1.5 [📄 7] are applicable.

NOTE: The illustrations in this manual are intended to provide a basic understanding and may deviate from the actual version.

1.1.1 Presentation of Warning Labels

To make risks clear, the following signal words and symbols are used for safety notes.



⚠ DANGER

Dangers for persons!

Non-observance will inevitably cause irreversible injury or death.



⚠ WARNING

Dangers for persons!

Non-observance can lead to irreversible injury and even death.



⚠ CAUTION

Dangers for persons!

Non-observance can cause minor injuries.

CAUTION

Material damage!

Information about avoiding material damage.

1.1.2 Definition of Terms

The term "product" or "module" replaces the product name on the title page in this manual.

1.1.3 Symbol definition

The following symbols are used in this manual:

■ Prerequisite for an action

1. Action 1

2. Action 2

⇒ Intermediate results

⇒ Final results

▶ 1.1.3 [7]: chapter number and [page number] in hyperlinks

1.1.4 Brands

- PROFINET is a registered trademark of PROFIBUS Nutzerorganisation e.V.
- EtherCAT is a registered trademark of Beckhoff Automation GmbH.
- EtherNet/IP™ is a registered trademark of ODVA, Inc.

1.1.5 Applicable documents

- General terms of business *
- Catalog data sheet of the purchased product *
- Assembly and operating manuals of the accessories *
- Software manual "EGI with PROFINET, EtherCAT or EtherNet/IP interface" *

The documents labeled with an asterisk (*) can be downloaded from [schunk.com](https://www.schunk.com).

1.1.6 Sizes

This operating manual applies to the following sizes:

- EGI 40
- EGI 80

1.1.7 Variants

This operating manual applies to the following variations:

- EGI PROFINET with the current release variant
- EGI EtherNet/IP™ with the current release variant
- EGI EtherCAT with the current release variant

1.2 Warranty

The warranty is 24 months or a maximum of 10 million cycles * from the date of delivery from the production facility if used as intended under the following conditions:

- Observe the ambient conditions and operating conditions, ▶ 2.5 [📄 11]
- Observe the specified maintenance and lubrication intervals, ▶ 8 [📄 53]

Parts touching the workpiece and wear parts are not included in the warranty.

* A cycle consists of a complete gripping process: "Open gripper" and "Close gripper".

1.3 Scope of delivery

The scope of delivery includes

- Gripper for small components EGI in the version ordered, firmware
- Assembly and Operating Manual
- QR slip for downloading the commissioning software
- EGI 40: 4x centering sleeve $\varnothing 5 \times 4.35$, 2x centering sleeve $\varnothing 8 \times 5.35$
- EGI 80: 4x centering sleeve $\varnothing 6 \times 5.35$, 2x centering sleeve $\varnothing 8 \times 5.35$

Scope of the commissioning software:

- Software manual "EGI with PROFINET, EtherCAT or EtherNet/IP interface"
- Assembly and Operating Manual
- Device description file

Note: For each fieldbus variant there is a separate device description file.

1.4 Accessories

The following accessories, which must be ordered separately, are required for the product:

- Power/logic connection cable
- Communication connection cable
- Adapter plate
- Gripper fingers

A wide range of accessories are available for this product

For information regarding which accessory articles can be used with the corresponding product variants, see catalog data sheet.

2 Basic safety notes

2.1 Intended use

The product is designed exclusively for gripping and temporarily holding workpieces or objects.

- The product may only be used within the scope of its technical data, ▶ 3 [□ 22].
- The product is intended for installation in a machine/ automated system. The applicable guidelines for the machine/ automated system must be observed and complied with.
- The product is intended for industrial and industry-oriented use. Its use outside enclosed spaces is only permitted if suitable protective measures are taken against outdoor exposure. The product is not suitable for use in salty air.
- The product can be used within the permissible load limits and technical data for holding workpieces during simple machining operations, but is not a clamping device according to EN 1550:1997+A1:2008.
- Appropriate use of the product includes compliance with all instructions in this manual.
- Any utilization that exceeds or differs from the appropriate use is regarded as misuse.

2.2 Constructional changes

Implementation of structural changes

Modifications, changes or reworking, e.g. additional threads, holes, or safety devices, can damage the product or impair its functionality or safety.

- Structural changes should only be made with the written approval of SCHUNK.

2.3 Spare parts

Use of unauthorized spare parts

Using unauthorized spare parts can endanger personnel and damage the product or cause it to malfunction.

- Use only original spare parts or spares authorized by SCHUNK.

2.4 Gripper fingers

Requirements of gripper fingers

- Only replace gripper fingers if no residual energy can be released.
- Make sure that the product and the top jaws are a sufficient size for the application.

2.5 Ambient conditions and operating conditions

Required ambient conditions and operating conditions

Incorrect ambient and operating conditions can make the product unsafe, leading to the risk of serious injuries, considerable material damage and/or a significant reduction to the product's life span.

- Make sure that the product is used only in the context of its defined application parameters, ▶ 3 [📄 22].

2.5.1 Environmental conditions

Transport and storage requirements

For transport and storage of product in original packaging, the following requirements apply:

- Loading and unloading with mechanical aids
- Ambient temperature from -40 °C to $+70\text{ °C}$
- Air humidity up to max. 85%

Operational requirements

The following requirements apply for operation of the product:

- Ambient temperature from $+5\text{ °C}$ to $+55\text{ °C}$
- Air humidity up to max. 65%

According to DIN EN 60068-2-6 and DIN EN 60068-2-27, in accordance with EN 60721-3-2 and EN 60721-3-3, the product was subjected to a vibration and shock inspection during transport and in operation with respect to the ambient influences and withstands the required loads.

The product may only be used in the following locations if additional measures are taken:

- In locations with a high level of ionizing radiation
- In locations with difficult operating conditions, e.g. due to caustic fumes, gases, oils or chemicals
- In facilities requiring special monitoring, e.g. in particularly at-risk areas

- In applications during which the product is exposed to unacceptably severe knocking or vibrations Suitable measures must be taken to reduce the amplitude or acceleration of such disturbances. Vibration-damping or vibration-absorbing systems are to be used in such cases.

The product must also not be used in potentially explosive zones.

2.5.2 Insulation resistance and voltage resistance in accordance with EN 60204-1

When measuring the insulation resistance and inspecting the voltage resistance of the machine/automated system, observe the following information in order to protect the product from damage:

- The electronics are connected to the housing ground, in order to protect against overvoltage.
- For measurements of the insulation resistance in accordance with EN 60204-1, no voltage levels above the permitted operating voltage range may be used. In addition, the maximum measuring current must be safely limited to values below 10mA.
- Before testing the voltage resistance of the machine/automated system in accordance with EN 60204-1, disconnect the product from the electric circuits to be tested. This applies to all connections on the product:
 - positive and negative connections of the power and logic supply
 - Fieldbus connections

2.6 Personnel qualification

Inadequate qualifications of the personnel

If the personnel working with the product is not sufficiently qualified, the result may be serious injuries and significant property damage.

- All work may only be performed by qualified personnel.
- Before working with the product, the personnel must have read and understood the complete assembly and operating manual.
- Observe the national safety regulations and rules and general safety instructions.

The following personal qualifications are necessary for the various activities related to the product:

Trained electrician

Due to their technical training, knowledge and experience, trained electricians are able to work on electrical systems, recognize and avoid possible dangers and know the relevant standards and regulations.

Qualified personnel

Due to its technical training, knowledge and experience, qualified personnel is able to perform the delegated tasks, recognize and avoid possible dangers and knows the relevant standards and regulations.

Instructed person

Instructed persons were instructed by the operator about the delegated tasks and possible dangers due to improper behaviour.

Service personnel of the manufacturer

Due to its technical training, knowledge and experience, service personnel of the manufacturer is able to perform the delegated tasks and to recognize and avoid possible dangers.

2.7 Personal protective equipment

Use of personal protective equipment

Personal protective equipment serves to protect staff against danger which may interfere with their health or safety at work.

- When working on and with the product, observe the occupational health and safety regulations and wear the required personal protective equipment.
- Observe the valid safety and accident prevention regulations.
- Wear protective gloves to guard against sharp edges and corners or rough surfaces.
- Wear heat-resistant protective gloves when handling hot surfaces.
- Wear protective gloves and safety goggles when handling hazardous substances.
- Wear close-fitting protective clothing and also wear long hair in a hairnet when dealing with moving components.

2.8 Notes on safe operation

Incorrect handling of the personnel

Incorrect handling and assembly may impair the product's safety and cause serious injuries and considerable material damage.

- Avoid any manner of working that may interfere with the function and operational safety of the product.
- Use the product as intended.
- Observe the safety notes and assembly instructions.
- Do not expose the product to any corrosive media. This does not apply to products that are designed for special environments.
- Eliminate any malfunction immediately.
- Observe the care and maintenance instructions.
- Observe the current safety, accident prevention and environmental protection regulations regarding the product's application field.

2.9 Transport

Handling during transport

Incorrect handling during transport may impair the product's safety and cause serious injuries and considerable material damage.

- When handling heavy weights, use lifting equipment to lift the product and transport it by appropriate means.
- Secure the product against falling during transportation and handling.
- Stand clear of suspended loads.

2.10 Malfunctions

Behavior in case of malfunctions

- Immediately remove the product from operation and report the malfunction to the responsible departments/persons.
- Order appropriately trained personnel to rectify the malfunction.
- Do not recommission the product until the malfunction has been rectified.
- Test the product after a malfunction to establish whether it still functions properly and no increased risks have arisen.

2.11 Disposal

Handling of disposal

The incorrect handling of disposal may impair the product's safety and cause serious injuries as well as considerable material and environmental harm.

- Follow local regulations on dispatching product components for recycling or proper disposal.

2.12 Fundamental dangers

General

- Observe safety distances.
- Never deactivate safety devices.
- Before commissioning the product, take appropriate protective measures to secure the danger zone.
- Disconnect power sources before installation, modification, maintenance, or calibration. Ensure that no residual energy remains in the system.
- If the energy supply is connected, do not move any parts by hand.
- Do not reach into the open mechanism or movement area of the product during operation.

2.12.1 Protection during handling and assembly

Incorrect handling and assembly

Incorrect handling and assembly may impair the product's safety and cause serious injuries and considerable material damage.

- Have all work carried out by appropriately qualified personnel.
- For all work, secure the product against accidental operation.
- Observe the relevant accident prevention rules.
- Use suitable assembly and transport equipment and take precautions to prevent jamming and crushing.

Incorrect lifting of loads

Falling loads may cause serious injuries and even death.

- Stand clear of suspended loads and do not step into their swiveling range.
- Never move loads without supervision.
- Do not leave suspended loads unattended.

2.12.2 Protection during commissioning and operation

Falling or violently ejected components

Falling and violently ejected components can cause serious injuries and even death.

- Take appropriate protective measures to secure the danger zone.
- Never step into the danger zone during operation.

2.12.3 Protection against dangerous movements

Unexpected movements

Residual energy in the system may cause serious injuries while working with the product.

- Switch off the energy supply, ensure that no residual energy remains and secure against inadvertent reactivation.
- The faulty actuation of connected drives may cause dangerous movements.
- Operating mistakes, faulty parameterization during commissioning or software errors may trigger dangerous movements.
- Never rely solely on the response of the monitoring function to avert danger. Until the installed monitors become effective, it must be assumed that the drive movement is faulty, with its action being dependent on the control unit and the current operating condition of the drive. Perform maintenance work, modifications, and attachments outside the danger zone defined by the movement range.
- To avoid accidents and/or material damage, human access to the movement range of the machine must be restricted. Limit/prevent accidental access for people in this area due through technical safety measures. The protective cover and protective fence must be rigid enough to withstand the maximum possible movement energy. EMERGENCY STOP switches must be easily and quickly accessible. Before starting up the machine or automated system, check that the EMERGENCY STOP system is working. Prevent operation of the machine if this protective equipment does not function correctly.

2.12.4 Protection against electric shock

Work on electrical equipment

Touching live parts may result in death.

- Work on the electrical equipment may only be carried out by qualified electricians in accordance with the electrical engineering regulations.
- Lay electrical cables properly, e. g. in a cable duct or a cable bridge. Observe standards.
- Before connecting or disconnecting electrical cables, switch off the power supply and check that the cables are free of voltage. Secure the power supply against being switched on again.
- Before switching on the product, check that the protective earth conductor is correctly attached to all electrical components according to the wiring diagram.
- Check whether covers and protective devices are fitted to prevent contact with live components.
- Do not touch the product's terminals when the power supply is switched on.

Possible electrostatic energy

Components or assembly groups may become electrostatically charged. When the electrostatic charge is touched, the discharge may trigger a shock reaction leading to injuries.

- The operator must ensure that all components and assembly groups are included in the local potential equalisation in accordance with the applicable regulations.
- While paying attention to the actual conditions of the working environment, the potential equalisation must be implemented by a specialist electrician according to the applicable regulations.
- The effectiveness of the potential equalisation must be verified by executing regular safety measurements.

2.12.5 Protection against magnetic and electromagnetic fields

Work in areas with magnetic and electromagnetic fields

Magnetic and electromagnetic fields can lead to serious injuries.

- Persons with pace-makers, metal implants, metal shards, or hearing aids require the consent of a physician before entering areas in which components of the electric drive and control systems are mounted, started up, and operated.
- Persons with pace-makers, metal implants, metal shards, or hearing aids require the consent of a physician before entering areas in which magnetic grippers or motor parts with permanent magnets are stored, repaired, or assembled.
- Do not operate high-frequency or radio devices in the proximity of electric components of the drive system and their feed lines.

If the use of such devices is necessary:

When starting up the electric drive and control system, check the machine or automated system for possible failures when such systems are used at different intervals and in different states of the control system. A special additional EMC test may be necessary if the system has a high risk potential.

2.13 Notes on particular risks



⚠ WARNING

Risk of injury from objects falling and being ejected!

Falling and ejected objects during operation can lead to serious injury or death.

- Take appropriate protective measures to secure the danger zone.



⚠ WARNING

Risk of injury due to unexpected movements!

If the power supply is switched on or residual energy remains in the system, components can move unexpectedly and cause serious injuries.

- Before starting any work on the product: Switch off the power supply and secure against restarting.
- Make sure, that no residual energy remains in the system.



⚠ WARNING

Risk of injury from crushing and impacts!

Serious injury could occur during movement of the base jaw, due to breakage or loosening of the gripper fingers or if the workpiece is lost.

- Wear suitable protective equipment.
- Do not reach into the open mechanism or the movement area of the product.



⚠ WARNING

Risk of injury from sharp edges and corners!

Sharp edges and corners can cause cuts.

- Use suitable protective equipment.



⚠ WARNING

Risk of burns through contact with hot surfaces!

Surfaces of components can heat up severely during operation. Skin contact with hot surfaces causes severe burns to the skin.

- For all work in the vicinity of hot surfaces, wear safety gloves.
- Before carrying out any work, make sure that all surfaces have cooled down to the ambient temperature.



⚠ WARNING

Risk of injury from objects falling in the event of an energy supply failure

In case of an energy supply failure, the gripping force decreases and a secure hold on the gripped workpiece cannot be guaranteed.

- Take suitable protective measures to secure the danger zone.



⚠ CAUTION

Risk of injury due to nickel-coated surfaces!

Contact with nickel-coated surfaces can cause allergic reactions.

- Wear suitable protective equipment.

3 Technical data

3.1 Name plate

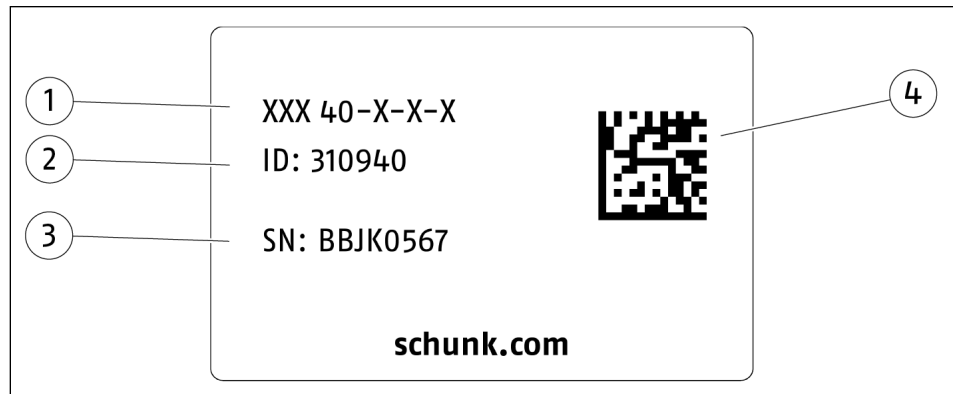

1 Product designation

2 ID

3 Serial number

4 Data matrix code

Scan code or enter serial number on the web and get all the product information: operating manuals, spare parts packages, software updates and much more.

For further information, visit [schunk.com/serialisierung](https://www.schunk.com/serialisierung)

A separate app may be required for scanning with a mobile phone.

3.2 Basic data

Designation	EGI 40	EGI 80
Mechanical operating data		
Weight [kg]	1.02	1.55
Gripping force [N]		
Min.	25	25
Max.	70	100
Ambient conditions and operating conditions		
Noise emission [dB(A)]	≤ 70	
IP rating	20	
Air purity class according to DIN EN ISO 14644-1:2015	5 *	6 *
Ambient temperature [°C]		
Min.	5	
Max.	55	
Electrical operating data		
Nominal voltage [VDC]	19.2 – 30	
Max. current input logic [A]	0.25	
Max. current input power [A]	0.7	1.5
Communication interface		
PROFINET [100 MBit/s]	IRT Class C	
EtherCAT [100 MBit/s]	2 port EtherCAT with EoE, FoE and CoE	
EtherNet/IP™ [10/100 MBit/s]	2 ports EtherNet/IP™ with ACD support	

* When using the product in a cleanroom, please note that grease may leak from moving parts, especially the base jaws and their guides.

More technical data is included in the catalog data sheet. Whichever is the latest version.

3.3 Diagrams

NOTE

The dependency of gripping force on finger length is shown in the diagrams below. The range shown has been determined with a standardized SCHUNK test finger. The gripping force attainable for a specific workpiece depends on the design of the gripper finger.

EGI 40

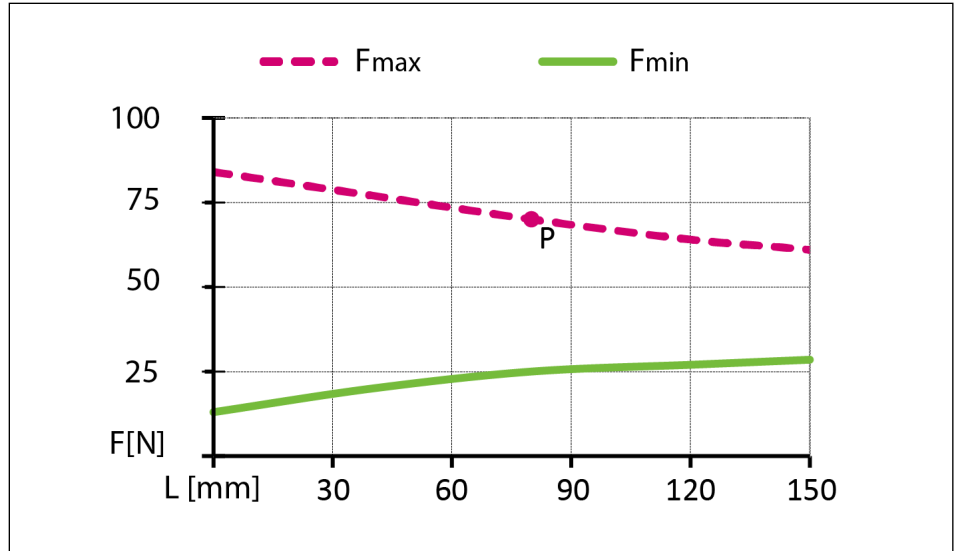

Gripping force diagram EGI 40

F [N] Gripping force L [mm] Finger length

EGI 80

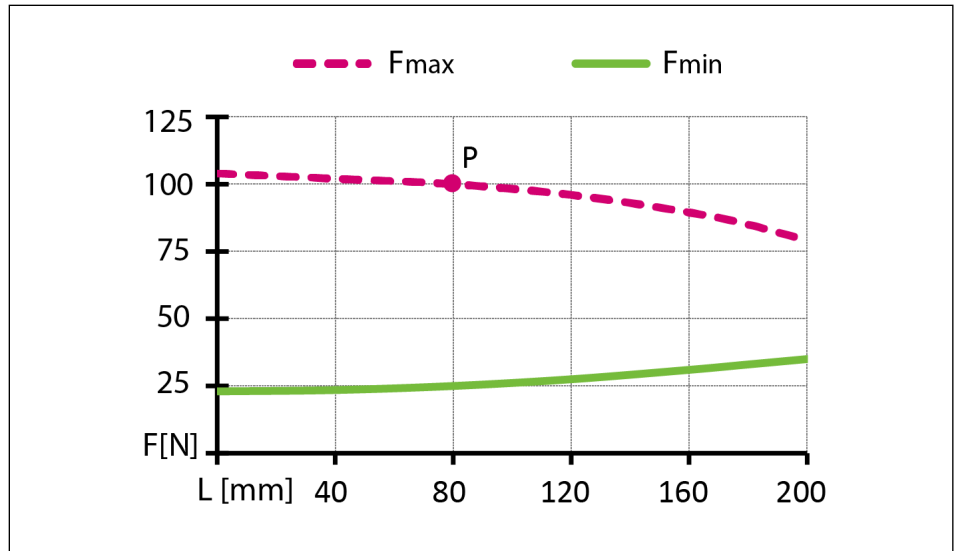

Gripping force diagram EGI 80

F [N] Gripping force L [mm] Finger length

The gripping force diagrams show the achievable gripping force range with a selected finger length. The gripping force can be specified in the range between F_{min} and F_{max} . For further information, see Software manual "EGI with PROFINET, EtherCAT or EtherNet/IP interface".

The specified gripping force is the force that the gripper applies at point P and that it can hold continuously. The position of point P is indicated in the main view in the catalog data sheet. To determine the nominal gripping force, the product is installed with a positive locking on an aluminum plate (200x200x20 mm³). The product can hold this nominal gripping force up to an ambient temperature of 55 °C. A temperature malfunction may occur if the product reaches excessively high temperatures. For measures to avoid an excess temperature fault, see chapter ▶ 5 [📄 35].

4 Design and description

4.1 Design

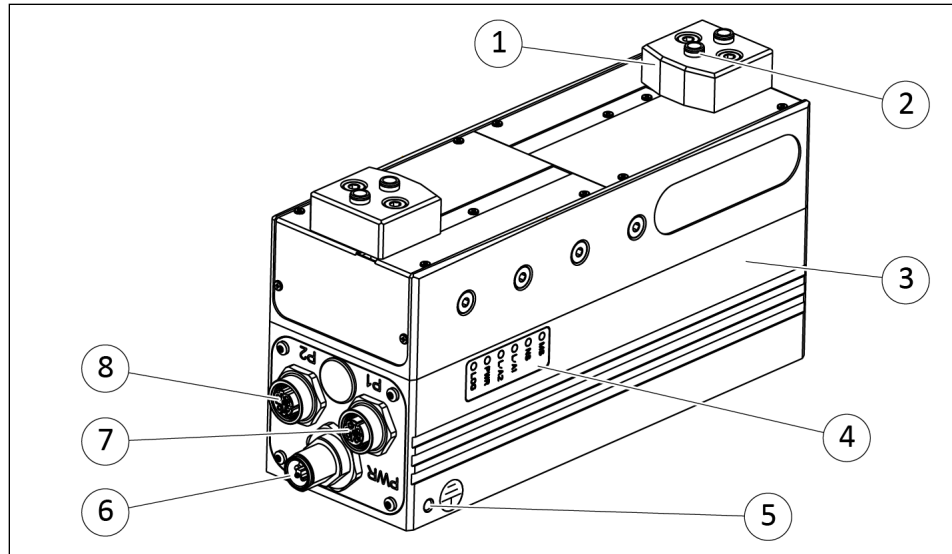

Gripper for small components EGI, example PROFINET variant

1	Base jaw
2	Centering sleeves for connecting the gripper fingers
3	Housing
4	LED status display
5	Connection for functional ground
6	Power connection PWR
7	Bus connection P1
8	Bus connection P2

4.2 Description

The product is a servo-electric 2-finger parallel gripper featuring integrated electronics and communication interface.

EGI 80 has a system for gripping force maintenance, EGI 40 has no gripping force maintenance.

The product is controlled via one of the following interfaces: PROFINET, EtherCAT or EtherNet/IP™.

In preparation for commissioning, the product has an integrated web application that can be accessed with a browser, ▶ 6.1 [46].

The web application is **not** available for EtherCAT.

- Details on the communication log for activation and exchange of information are described in the software manual, ▶ 1.1.5 [7].
- For further information on the bus system PROFINET, see chapter ▶ 4.5 [33].

- For further information on the bus system EtherNet/IP™, see chapter ▶ 4.6 [📄 34].
- For further information on the bus system EtherCAT, see chapter ▶ 4.7 [📄 34].

4.3 Functional principle

- The product can be activated directly from the PLC like a drive controller without gateways.
- The position is freely programmable within the available stroke.
- The gripping force is freely programmable within the technical specification.
- Positioning (position control):
 - *With gripping force maintenance*: When the requested position is reached, the gripping force maintenance is activated and the motor is switched off.
 - *Without gripping force maintenance*: When the requested position is reached, the motor remains energized.
- Gripping (power control):
 - *With gripping force maintenance*: When a workpiece is gripped, the gripping force maintenance is activated and the motor is switched off.
 - *Without gripping force maintenance*: When a workpiece is gripped, the motor remains energized.

4.4 Displays and control elements

4.4.1 LED status display PROFINET

The status values of the product are displayed via the LED status display.

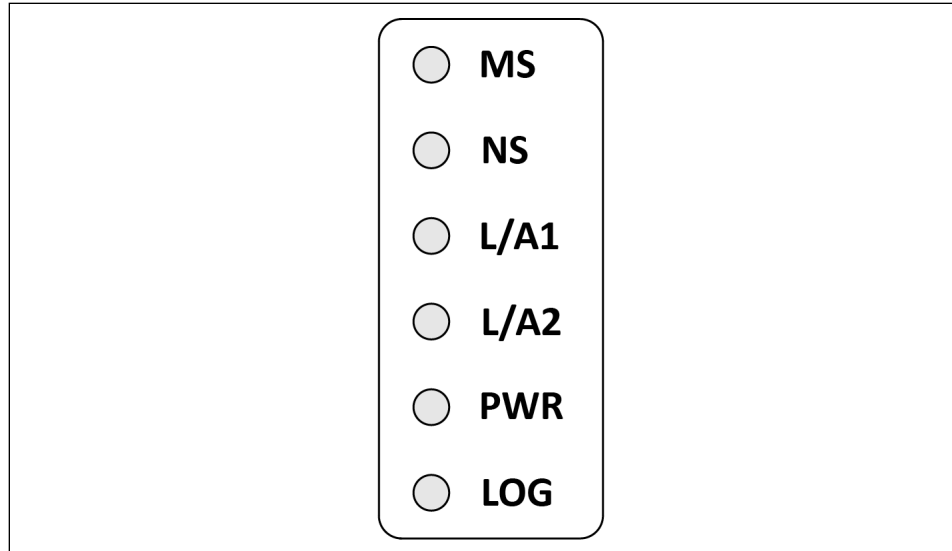

LED status display PROFINET

LED	Designation	Color	Function
LOG	Supply logic	Green	<p>LED off: No supply voltage logic present, or supply voltage logic is outside the operating range for the module.</p> <p>LED lights up green: Supply voltage logic is present.</p>
PWR	Supply power	Green	<p>LED off: No supply voltage power present, or supply voltage power is outside the operating range for the module.</p> <p>LED lights up green: Supply voltage power is present.</p>
L/A2	Link/Activity 2: Network connection and network activity of port P2	Green	<p>LED off: Connection inactive, communication inactive</p> <p>LED lights up green: Connection active, communication inactive</p> <p>LED flashes quickly: Connection active, communication active</p>
L/A1	Link/Activity 1: Network connection and network activity of port P1	Green	<p>LED off: Connection inactive, communication inactive</p> <p>LED lights up green: Connection active, communication inactive</p> <p>LED flashes quickly: Connection active, communication active</p>
NS	Network status	Red/ Green	<p>LED off: No connection to the control system available.</p> <p>LED lights up green: Connection to the control system present and control system is in "Run" mode.</p>

LED	Designation	Color	Function
			<p>LED flashes green x1: Connection to the control system present and control system is in "Stop" mode. The IRT synchronization is not yet finished.</p> <p>LED flashes green continuously: The network participant is in identification mode.</p> <p>LED lights up red: Serious network error present.</p> <p>LED lights up red x1: The station name is not known.</p> <p>LED lights up red x2: The IP address is not known.</p> <p>LED lights up red x3: A configuration error is present.</p>
MS	Module status	Red/ Green	<p>LED off: The product is in setup or NW_Init status (NW_Init Status = initialization state).</p> <p>LED lights up green: The product is in normal operating mode.</p> <p>LED flashes green x1: The product is currently processing diagnostics processes.</p> <p>LED lights up red: Serious error. The product is not ready for operation.</p>

4.4.2 LED status display EtherNet/IP™

The status values of the product are displayed via the LED status display.

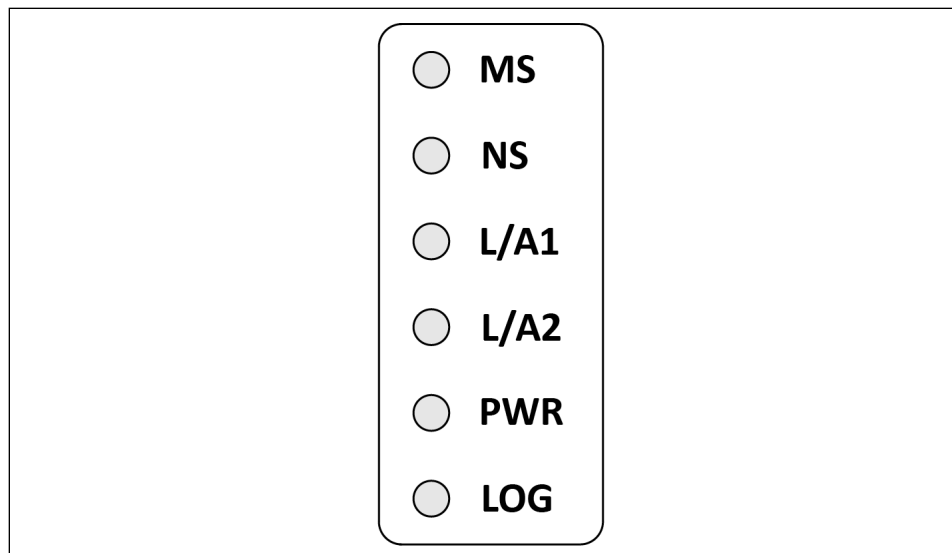

LED, EtherNet/IP™

LED	Designation	Color	Function
LOG	Supply logic	Green	<p>LED off: No supply voltage logic present, or supply voltage logic is outside the operating range for the module.</p> <p>LED lights up green: Supply voltage logic is present.</p>
PWR	Supply power	Green	<p>LED off: No supply voltage power present, or supply voltage power is outside the operating range for the module.</p>

LED	Designation	Color	Function
			LED lights up green: Supply voltage power is present.
L/A2	Link/Activity 2: Network connection and network activity of port P2	Green	LED off: Connection inactive, communication inactive LED lights up green: Connection active, communication inactive LED flashes quickly: Connection active, communication active
L/A1	Link/Activity 1: Network connection and network activity of port P1	Green	LED off: Connection inactive, communication inactive LED lights up green: Connection active, communication inactive LED flashes quickly: Connection active, communication active
NS	Network status	Red/ Green	LED off: No supply voltage present and/or no IP address. LED lights up green: Product is online. One or more connections are/have been established (CIP™ Class 1 or 3) LED flashes green: Product is online, but has not yet established a connection. LED lights up red: Duplicate network address present. Serious network error present. LED flashes red: Timeout for one or more connections.
MS	Module status	Red/ Green	LED off: No supply voltage present. LED lights up green: Controlled by a scanner in operating mode. LED flashes green: The product is not configured, scanner in sleep mode. LED lights up red: Serious error. The product is not ready for operation. LED flashes red: Removable malfunction/errors. The product is configured, but the stored parameters differ from the parameters currently in use.

4.4.3 LED status display EtherCAT

The status values of the product are displayed via the LED status display.

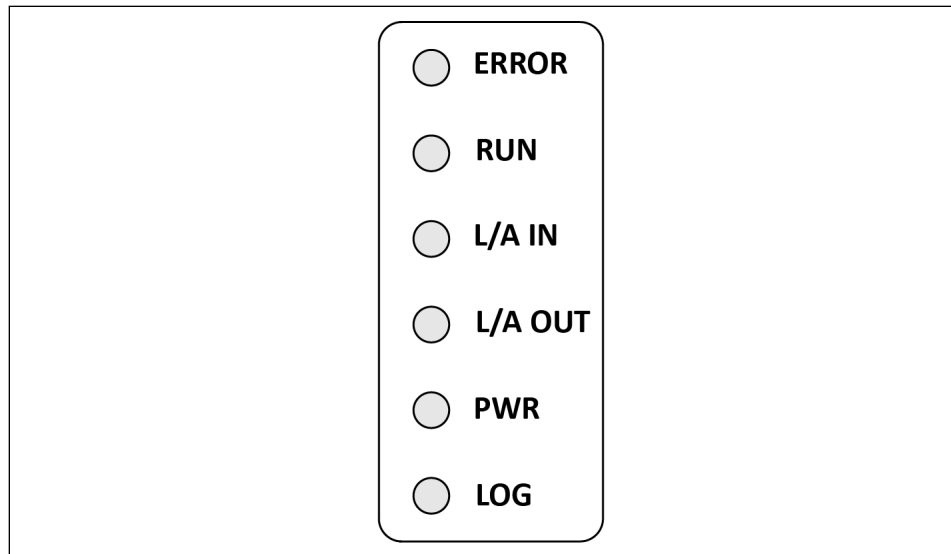

LED EtherCAT

LED	Designation	Color	Function
LOG	Supply logic	Green	<p>LED off: No supply voltage logic present, or supply voltage logic is outside the operating range for the module.</p> <p>LED lights up green: Supply voltage logic is present.</p>
PWR	Supply power	Green	<p>LED off: No supply voltage power present, or supply voltage power is outside the operating range for the module.</p> <p>LED lights up green: Supply voltage power is present.</p>
L/A OUT	Link/Activity 2: Network connection and network activity of port P2	Green	<p>LED off: Connection inactive, communication inactive</p> <p>LED lights up green: Connection active, communication inactive</p> <p>LED flashes quickly: Connection active, communication active</p>
L/A IN	Link/Activity 1: Network connection and network activity of port P1	Green	<p>LED off: Connection inactive, communication inactive</p> <p>LED lights up green: Connection active, communication inactive</p> <p>LED flashes quickly: Connection active, communication active</p>
RUN	Run LED	Red/ Green	<p>LED off: No supply voltage on and/or EtherCAT device in 'INIT' state.</p> <p>LED lights up green: EtherCAT-Device is in 'OPERATIONAL' state.</p> <p>LED flashes green: EtherCAT-Device is in 'PRE-OPERATIONAL' state.</p>

LED	Designation	Color	Function
			<p>LED flashes single green: EtherCAT-Device is in 'OPERATIONAL' state.</p> <hr/> <p>LED flickers: EtherCAT-Device is in 'BOOT' state.</p> <hr/> <p>LED lights up red: A serious fault is present. The bus interface has been put into a physically passive state. Contact SCHUNK Service.</p>
ERROR	Error LED	Red	<p>LED off: No supply voltage present and/or no error.</p> <hr/> <p>LED flashes red: Invalid configuration. The status change requested by the master is not possible due to invalid register or object settings.</p> <hr/> <p>LED flashes single red: Unrequested status change. Device has changed the EtherCAT-status independently.</p> <hr/> <p>LED flashes double red: Timeout of the Sync Manager Watchdog</p> <hr/> <p>LED lights up red: A serious fault is present. The bus interface has been put into a physically passive state. Contact SCHUNK Service.</p> <hr/> <p>LED flickers: Boot error, e.g. due to a failed firmware download</p>

4.4.4 Service interface

NOTE

Only SCHUNK service engineers may access the SERVICE interface.
Do not remove the cover plug (1).

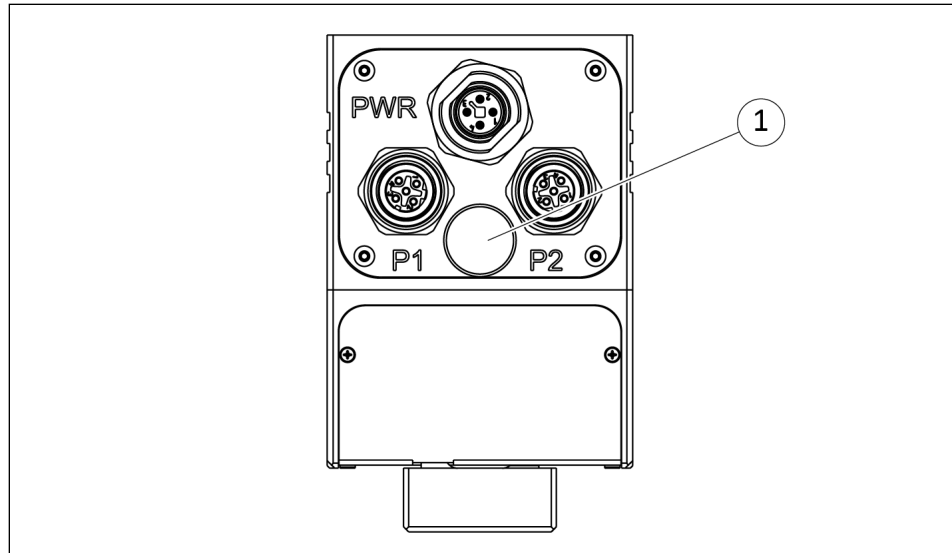

Service interface

1 Service interface cover plug

4.5 Types of communication of PROFINET

The product supports the communication types:

- **TCP/IP:**
Open Ethernet TCP/IP communication without real time requirements
- **RT (Real Time):**
IO data exchange between automation devices in real time (>1 ms).
- **IRT (Isochronous Real Time):**
 - Smallest supported network cycle time 0.25ms = 250µs
 - Synchronization of the application not possible

The product is incorporated into the PROFINET network as an IO device.

4.6 Communication types of EtherNet/IP™

The product supports the EtherNet/IP™ communication types:

- Cyclic and acyclic EtherNet/IP™ communication
- Protocol implementation according to the Common Industrial Protocol (CIP™) defined by the Open DeviceNet Vendor Association (ODVA®)
- Two EtherNet/IP™ ports
- Topology: linear
- 10/100 Mbit full/half duplex Ethernet
- Address Conflict Detection (ACD)

4.7 Communication types of EtherCAT

The product supports the EtherCAT communication types:

- Full EtherCAT Slave with 4 FMMUs (Fieldbus Memory Management Unit) and 4 Sync Managers
- CANopen over EtherCAT (CoE)
- Ethernet over EtherCAT (EoE)
- Two EtherCAT ports
- 10/100 Mbit full/half duplex Ethernet

5 Assembly and settings

5.1 Assembling and connecting



⚠ WARNING

Risk of injury due to unexpected movements!

If the power supply is switched on or residual energy remains in the system, components can move unexpectedly and cause serious injuries.

- Before starting any work on the product: Switch off the power supply and secure against restarting.
- Make sure, that no residual energy remains in the system.

NOTE

A temperature malfunction may occur if the product reaches excessively high temperatures.

- Ensure sufficient heat dissipation via the customer's mounting surface.
- Mount the product so that sufficient cooling is guaranteed.
- The size of the cooling surface depends on the application. Avoid exposure to additional heat e.g. caused by attachments or by the attached axles.

Overview

1. Check the evenness of the mounting surface, ▶ 5.2 [36].
2. Choose the installation position so that connection cables are not damaged or cannot wrap around the product when swiveling.
3. Screw the product to the machine/system, ▶ 5.2 [36].
 - ⇒ Use suitable connecting elements (adapter plates) if necessary.
If required, adapter plates can be requested from SCHUNK.
 - ⇒ Observe the maximal tightening torque, admissible screw-in depth and, if necessary, strength class.
4. Secure the gripper fingers to the base jaws, ▶ 5.2 [38].
 - ⇒ Observe the maximal tightening torque, admissible screw-in depth and, if necessary, strength class.
5. Connect the functional ground cable between the product and the machine/system, ▶ 5.3 [39].
6. Place the voltage supply cable on the connector and screw in the threaded ring, ▶ 5.3 [39].

7. Connect the communication cable to the sockets and screw in the threaded ring, ▶ 5.3 [39]. Observe the tightening torque, ▶ 5.3.2 [42].
8. If applicable: connect multiple products to each other, ▶ 5.4 [45].
9. Make sure that the connections are not stressed due to tensile and pressure forces. Apply appropriate strain relief devices if required.

5.2 Mechanical connection

Evenness of the mounting surface

The values apply to the whole mounting surface to which the product is mounted.

Edge length	Permissible unevenness
< 100	< 0.02
> 100	< 0.05

Tab.: Requirements for evenness of the mounting surface (Dimensions in mm)

Connections at the housing

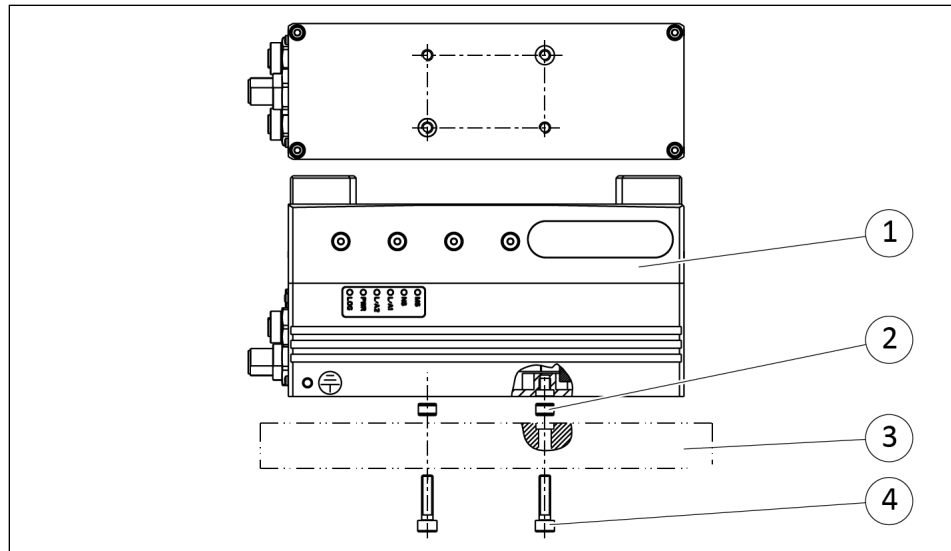

Connections on housing, mounting example with adapter plate

1	Housing	3	Adapter plate (optional)
2	Centering sleeve	4	Mounting screw

Item	Designation	EGI
4	Mounting screw, (4 Piece)	M5
	Screw-in depth [mm]	
	Min.	7
	Max.	8
	Tightening torque [Nm]	9.0
2	Centering sleeve [mm] (2 Piece)	Ø8

Tab.: Depth of engagement and tightening torque, product to adapter plate

Connections at the base jaws

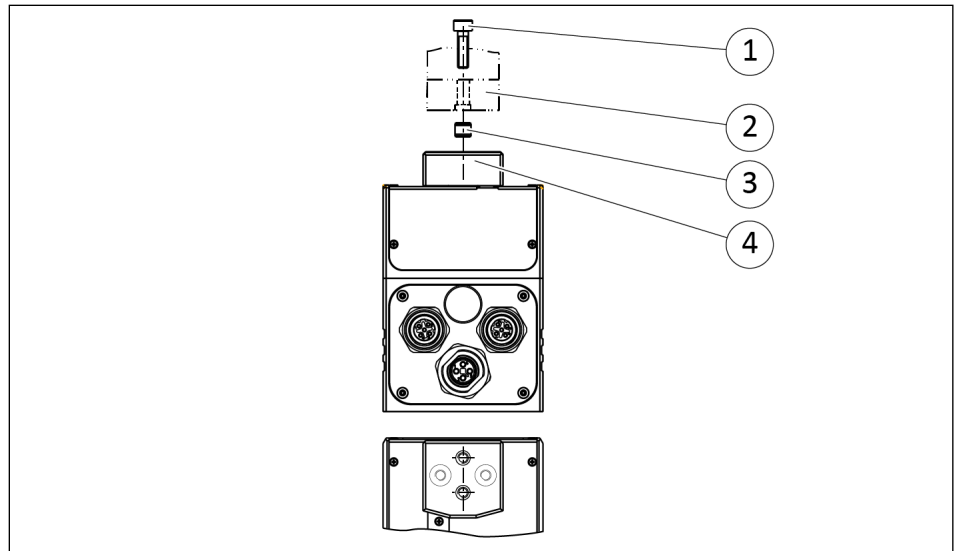

Connections to the base jaws

1	Mounting screw	3	Centering sleeve
2	Gripper fingers	4	Base jaw

Item	Designation	EGI	
		40	80
1	Mounting screw, (2 Piece)	M3	M4
	Screw-in depth [mm]		
	Min.	6.5	6.5
	Max.	7.5	7.5
	Tightening torque [Nm]	1.8	4.5
3	Centering sleeve [mm] (2 Piece)	∅5	∅6

Tab.: Depth of engagement and tightening torque, gripper finger to base jaw

5.3 Electrical connection

CAUTION

Risk of damage to the electronics!

A faulty connection can cause damage to the internal electronics.

- The supply network must be a network of type "PELV" for power and logic.
- Observe the PIN assignment of the connecting terminals.
- Make sure that all components are grounded correctly.

NOTE

Regenerative energy recovery systems for sizes 50 and 70

During operation, energy can be temporarily fed back into the supply via the power unit. Regenerative energy recovery mainly occurs during braking operations in the product positioning mode. Increased travel speed of the gripper fingers enhances this effect.

- The power supply unit must have a regenerative capacity of at least 30 V.

NOTE

Regenerative energy recovery systems for sizes 60 and 80

No significant energy recovery occurs during operation.

- The power unit is completely electrically isolated internally from the logic section (isolation voltage 500 V). This does not apply to the Modbus RTU variant.
-

5.3.1 Pin allocation

Voltage supply

EGI 40

The voltage is supplied via an A-coded M8 connector.

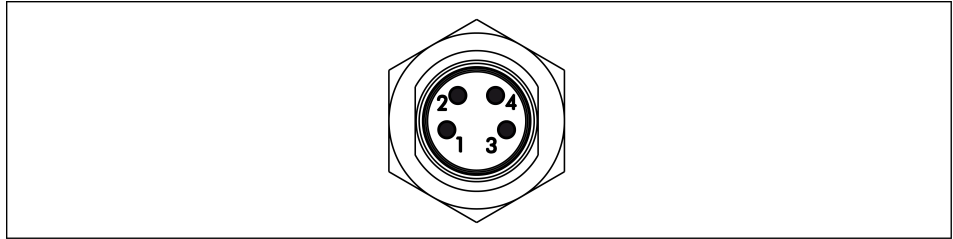

EGI 40: Pin allocation for voltage supply connector

1	+24 V Logic
2	GND Logic
3	GND Power
4	+24 V Power

EGI 80

The voltage is supplied via a T-coded M12 connector.

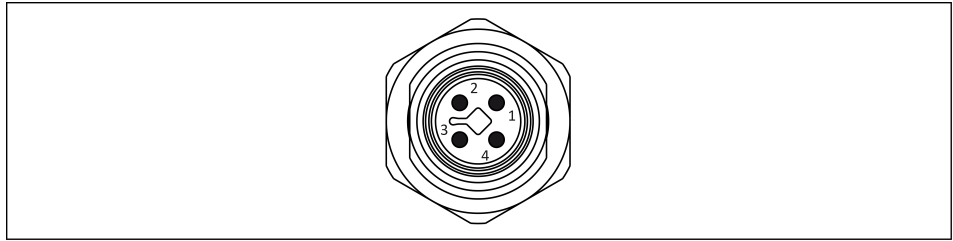

EGI 80: Pin allocation for voltage supply connector

1	+24 V Logic
2	GND Logic
3	GND Power
4	+24 V Power

Communication

EGI 40: The communication interface (PROFINET, EtherCAT or EtherNet/IP™) is implemented via two D-coded M8 sockets.

EGI 80: The communication interface (PROFINET, EtherCAT or EtherNet/IP™) is implemented via two D-coded M12 sockets.

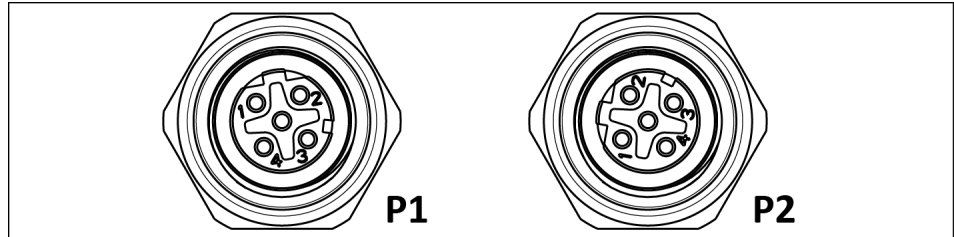

Pin allocation for sockets P1 and P2

	Socket P1	Socket P2
1	TDA+	RDB+
2	RDA+	TDB+
3	TDA-	RDB-
4	RDA-	TDB-
5	Shield	Shield

5.3.2 Cable connections

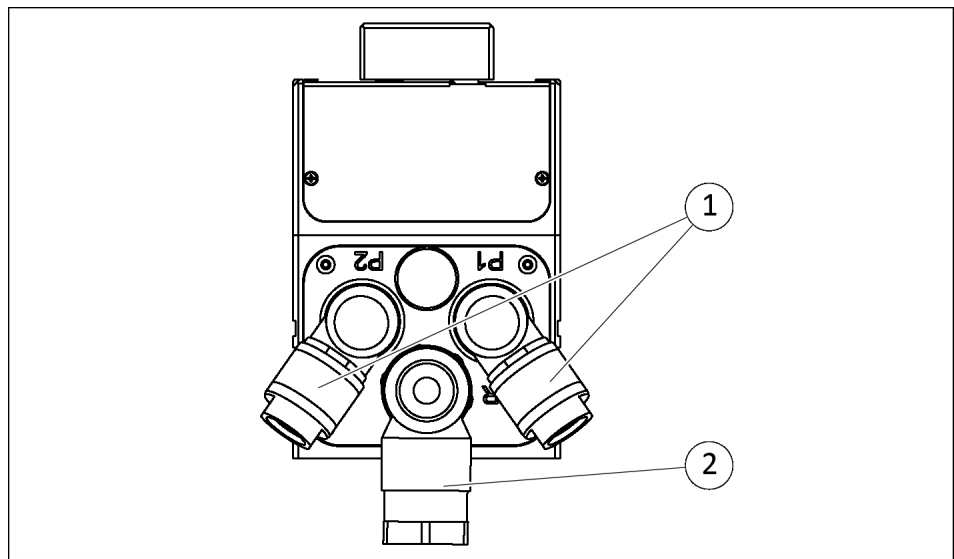

Cable outlets (example EGI 80)

- | | |
|---|--------------------------------|
| 1 | Cable connector communication |
| 2 | Cable connector voltage supply |

CAUTION

Material damage due to incorrect assembly!

- When connecting the cable, observe the maximum tightening torque of 0.8 Nm for the cable and do not exceed this amount.
SCHUNK recommends using a suitable tool to generate the required tightening torque, thereby ensuring a permanently functioning communication and energy connection.
- Make sure that the connections are not stressed due to pulling or pressure forces or due to vibrations. Apply the corresponding strain relief devices if required.

5.3.3 Wiring diagram

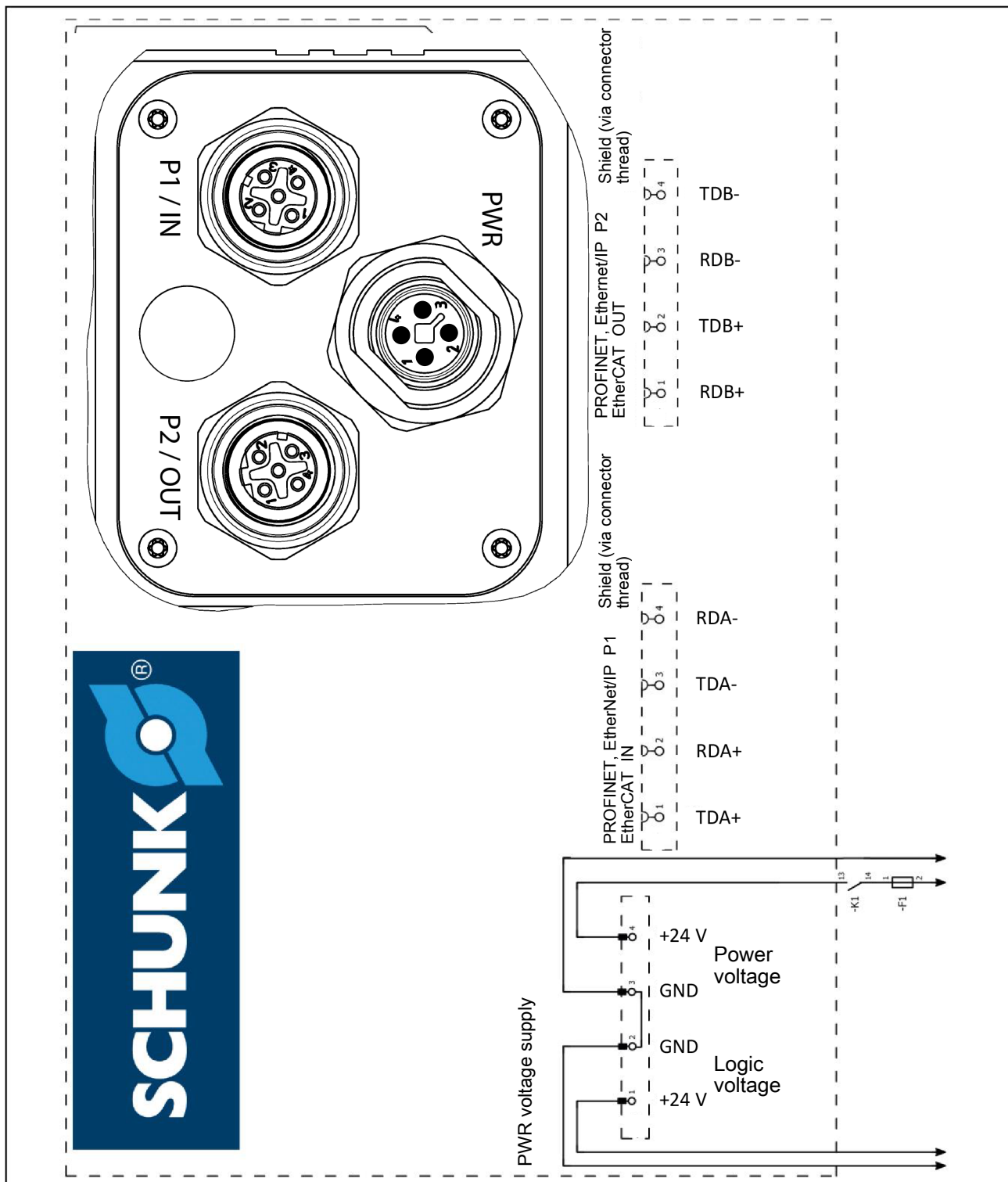

Wiring diagram EGI

5.3.4 External protection

The power circuit for the product must be protected at the customer site by a circuit breaker, ▶ 3 [22].

5.3.5 Connecting the ground cable (functional ground)

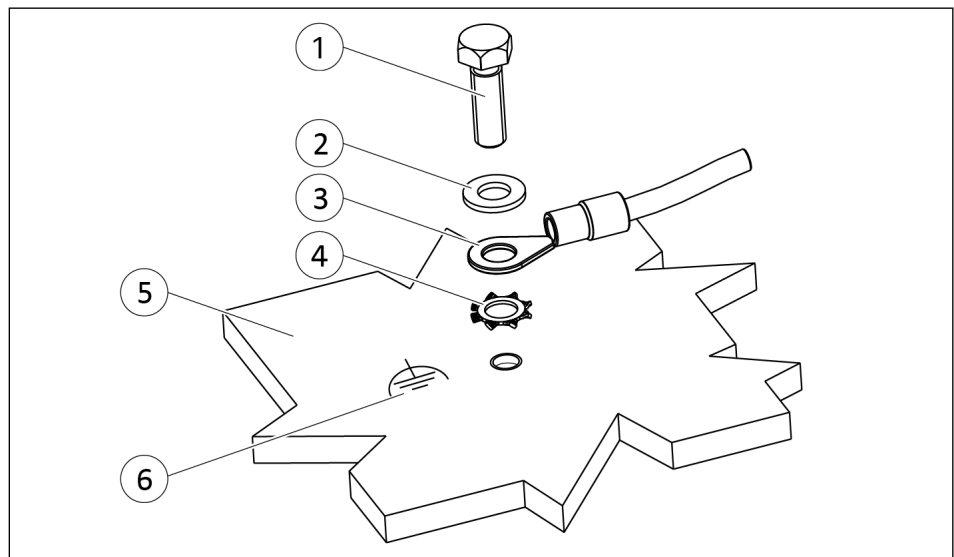

Ground connection

1	Screw *	4	Toothed lock washer
2	Washer	5	Product
3	Cable lug	6	Ground marking

*) Tightening torque: 5 Nm



A ground connection with a sufficient cross-section must be established between the product and the machine on the customer's premises.

Mount the ground cable (functional ground) on the threaded hole marked with the ground marking.

NOTE

Only connect the ground cable (functional ground) at the location intended for this purpose.

Always mount the ground cable individually. A green-yellow wire strand color is not permitted.

Always use all components to fasten the ground cable (functional ground) and install them in this order: toothed lock washer, cable lug, washer and screw. See "Ground connection" diagram. Observe the tightening torque.

5.4 Combining multiple products

This chapter describes the basic principle for the communication connection.

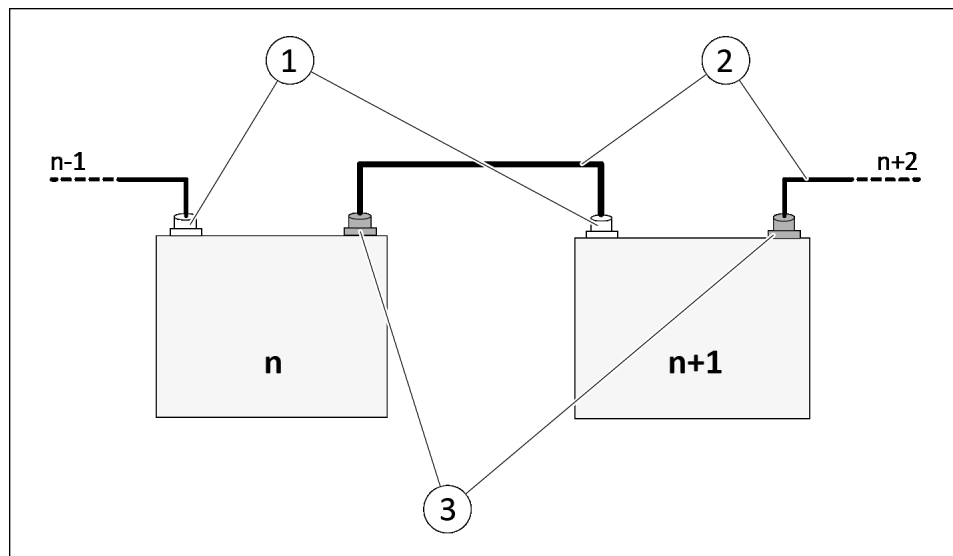

Combining multiple products

1	PROFINET, EtherCAT or EtherNet/IP™, Socket P1
2	Bus cable
3	PROFINET, EtherCAT or EtherNet/IP™, Socket P2

When several products are combined, communication is transferred from socket P1 to socket P2 via an internal switch:

- Connect socket P1 of product "n+1" via a bus cable to socket P2 of the "n" product.

6 Start-up

The product is commissioned via the PLC.

SCHUNK provides the following tools for preparing the commissioning:

- Web application, ▶ 6.1 [46].

6.1 Preparing commissioning with the web application

NOTE

The product is supplied either with PROFINET, EtherCAT or EtherNet/IP™. The Web application is **not** available for EtherCAT.

Using the web application, it is possible, prior to integration of the product in the system (▶ 6.2 [48]), to test the movement functions of the product and display status information. The following functions are possible:

- Execution of movements (referencing, jog mode, positioning, gripping)
- Configuring (limit stroke, transfer work settings, reboot)
- Service functions (display and save general product information and errors, download the GSDML file)

Starting the web application

Prerequisites

- An IP address was assigned to the product e.g. by being registered as a component in the PROFINET network or by applying the commissioning tool "Anybus-IP Config Tool".
Note: According to the bus system specifications for PROFINET the product is supplied without IP address.

NOTE

The "Anybus-IP Config Tool" (found in zipped file: HMS IPconfig - Utility for module TCP/IP configuration) can be used to assign an IP address to a module or to determine the IP address of a module. This tool can be downloaded from "https://www.anybus.com". For a detailed description of downloading the tool see chapter ▶ 14.4 [78].

- The product is connected to a 24 V voltage supply.
The motor voltage can be disconnected at any time by an easily accessible emergency stop switch.
- The product is connected directly to the EtherNet port of the PC or in the same network.

- The product and PC are connected in the same network (subnet).
1. Start browser. Note: The web application is optimized for Firefox and Chrome.
 2. Enter the allocated IP address of the product in the address line of the browser.
 - ⇒ The web application is started. The start screen will appear with the product illustrated as well as identification and status information.

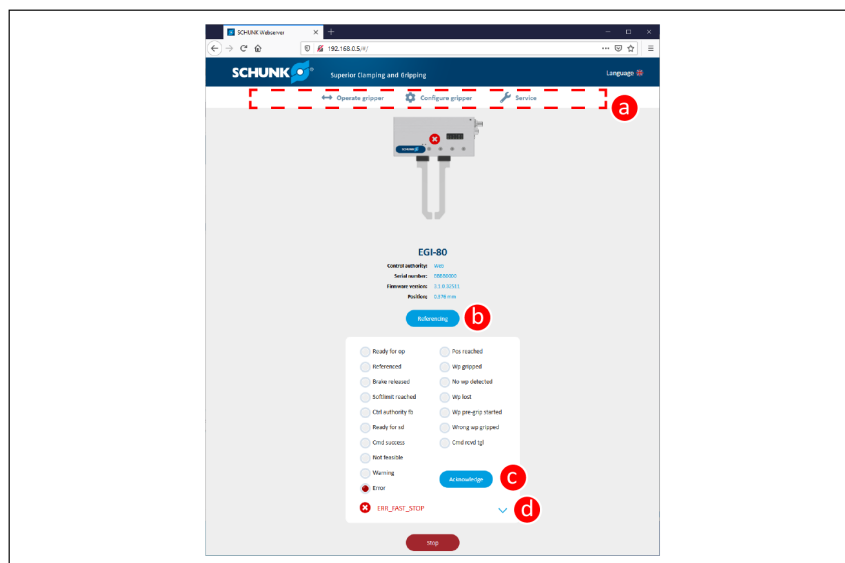

- ⇒ Any possible errors will be shown in the lower area of the status information (d) that can be opened out.
3. If applicable, rectify the error and acknowledge the error message via the button (c).
 - ⇒ The product is ready for operation.
 4. The product can be referenced via the button (b).
 5. Using the tab in area (a), the following functions are possible: moving and configuring the product, displaying and saving error messages.

6.2 Commissioning the product

System integration

The communication protocol "SCHUNK Flexible Protocol" is available for operation within the plant.
For further information, see Software manual "EGI with PROFINET, EtherCAT or EtherNet/IP interface".

NOTE

Due to the selected hardware components, it may be necessary to perform a byte swap between little-endian and big-endian in the cyclic protocol.

General

1. Connect logic and power supply.
 - ⇒ LED LOG and PWR light up green.
 2. Connect the network cable.
 - ⇒ LED MS lights up green.
 - ⇒ LED NS lights up green.
- ⇒ Product can now be put into operation with the corresponding control software.

PROFINET:

Overview

1. Open control software (e.g. TIA Portal from Siemens) and import product GSDML.
2. Open the hardware configuration in the control system.
3. Search for the product from the hardware catalog and integrate it into the hardware configuration.
4. Carry out the required configuration and upload the hardware configuration to the controller.
5. Assign the hardware name to the product.
 - ⇒ If the product is displayed in the online status, the commissioning was successful.

NOTE

For detailed information on integrating the product into the control software, see chapter ► [14.1 \[59\]](#).

Overview**EtherNet/IP™:**

1. Open the control software (e.g. Studio 5000 ® from Rockwell).
2. Manually load the EDS file into the library of the control software.
 - ⇒ Note: The product cannot yet be integrated into the hardware via a search.
3. Create I/O configuration.
4. Parameterize product.
5. Transfer I/O configuration to the controller.
 - ⇒ If the product is displayed in the online status, the commissioning was successful.

NOTE

For detailed information on integrating the product into the control software, see chapter ▶ 14.2 [64]

Overview**EtherCAT:**

1. Copy the EDS file manually into the installation folder of the TwinCAT installation.
 - ⇒ Note: The product cannot yet be integrated into the hardware via a search.
2. Open the control software (e.g. TwinCAT ® from BECKHOFF).
3. Create I/O configuration.
4. Parameterize product.
5. Establish a link between the hardware signals and the software variables.
6. Compile project.
7. Transfer project to the controller.
8. Assign IP address to the product.
 - ⇒ If the product is displayed in the online status, the commissioning was successful.

NOTE

For detailed information on integrating the product into the control software, see chapter ▶ 14.3 [72].

6.3 Operating behavior of the product

If a product is connected, the following operating behavior will be exhibited:

- **Behavior when switching on the voltage supply:**
 - After switching on the voltage supply, the product will be in the "fast stop" mode and will not perform any movements.
 - The product will only perform movements if "fast stop" was acknowledged and the product is driven by the superordinate control system.
- **Behavior on canceling the connection between the superordinate control system and the product:**

On canceling the connection, the product will enter "fast stop" mode and will not perform any movements.
- **With PROFINET: Behavior with IOPS=BAD:**

The superordinate control system will send data to the product periodically. The data qualifier IOPS contained there will provide information about the validity of the initial data. If this data qualifier has the value "BAD", the product changes to "fast stop" status and does not perform any movement.

7 Troubleshooting

NOTE

- For information on error codes, see Software manual "EGI with PROFINET, EtherCAT or EtherNet/IP interface".
- For information on LEDs, see chapter ▶ 4.4.1 [28].

7.1 Communication malfunction

Possible cause	Corrective action
The connection between the product and PLC was interrupted	Check bus cable for correct connection. Check bus cable for damage and replace if necessary.
Values are taken over in the non-volatile memory, but not activated	Restart product after writing. OR: Before saving, stop the product using fast stop. IMPORTANT! New values are not saved in non-volatile memory if the product is under control or in motion.

7.2 Product moves in a jerky fashion, is sluggish or blocked

Possible cause	Corrective action
Product is overloaded	Check load situation, e.g. maximum permissible finger weight, maximum permissible finger length, load data of the base jaws. Check product, contact SCHUNK Service if necessary.
Voltage supply malfunction	Check the power output of the power supply unit. Check power cable line and cable cross sections (high loss of voltage possible with 24 VDC power supply). Check power cable line for shorts and cable breakage.
Sporadic breaks in communication	Check bus connection. ▶ 5.3 [39]
Dirt deposits on product (increasing sluggishness)	Clean product. ▶ 8.1 [53]
Moisture in the product (oil, cutting fluid, cleaning agent)	Clean product. ▶ 8.1 [53] Check for appropriate IP class.
Mechanical defect	Check product and replace if necessary.

7.3 Product does not open

Possible cause	Corrective action
No voltage connected. (emergency stop chain interrupted, safety light curtain triggered.)	Check the power supply requirement, ▶ 3 [📄 22].
Insufficient voltage.	
Error message present	Eliminate fault and acknowledge error message, see software manual.
Erroneous movement parameter	Check setpoint settings and enter suitable values, see the software manual.

8 Maintenance

8.1 Maintenance intervals

This product must not be disassembled for maintenance.

Perform all maintenance work without a gripped workpiece!

Interval (million cycles)	Maintenance work
2 / as required	<p>Clean product with a solvent-free cleaning agent. Blow all coarse dirt and chips out of the cavities in the product with compressed air.</p> <hr/> <p>Inspect the product for damage. Replace the product if necessary.</p> <p>Have all repair work on the product carried out only by SCHUNK.</p>

8.2 Lubricants and lubricating points

Relubrication is not required.

The product contains food-compliant lubricants. All guide-related components are designed with food-compliant lubricants. **The requirements of standard EN 1672-2:2020 are not fully met.**

The product contains the following components in the area separated from the guide, the lubricants of which are **not** food compliant:

Greasing area	Lubricant
Motor mount	Commercially available bearing grease
Motor gear stage	Gear grease
Rolling bearing, angular gear	Commercially available bearing grease

8.3 Disassembly and assembling

This product must not be disassembled for maintenance.

CAUTION

Material damage due to improper disassembly!

Incorrect works can cause damage to the mechanics and internal electronics.

- Disassembly or opening of the product is not permitted.
- Only allow SCHUNK to repair the product.

9 EU-Declaration of Conformity

Manufacturer/ Distributor	SCHUNK SE & Co. KG Toolholding and Workholding Gripping Technology Automation Technology Bahnhofstr. 106 - 134 D-74348 Lauffen/Neckar
Product designation:	Gripper for small components / EGI /electric
ID number	1328833, 1328834, 1328836, 1328837, 1328835, 1328838

We hereby declare on our sole authority that the product meets the requirements of the following directives at the time of the declaration.

The declaration is rendered invalid if modifications are made to the product.

- **EMC Directive 2014/30/EU**

Directive of the European Parliament and the Council of February 26, 2014 on the harmonization of the laws of the Member States relating to electromagnetic compatibility

Applied harmonized standards, especially:

EN IEC 61000-6-2:2019	Electromagnetic compatibility (EMC) – Part 6-2: Generic standards – Immunity standard for industrial environments
EN IEC 61000-6-4:2019	Electromagnetic compatibility (EMC) – Part 6-4: Generic standards – Emission standard for industrial environments

Signed for and on behalf of: SCHUNK SE & Co. KG

Signature: see original declaration

Lauffen/Neckar, October 2023

Dr.-Ing. Manuel Baumeister,
Head of Systems Engineering,
Technology & Innovation

10 Translation of the original declaration of incorporation

in terms of the Directive 2006/42/EG, Annex II, Part 1 Section B.

Manufacturer/
Distributor SCHUNK SE & Co. KG
Toolholding and Workholding | Gripping Technology | Automation
Technology
Bahnhofstr. 106 – 134
D-74348 Lauffen/Neckar

We hereby declare that the partly completed machine described below

Product designation: Gripper for small components / EGI /electric
ID number 1328833, 1328834, 1328836, 1328837, 1328835, 1328838

meets the following basic occupational health and safety of the Machinery Directive 2006/42/EC:

No. 1.1.1, No. 1.1.2, No. 1.1.3, No. 1.1.5, No. 1.3.2, No. 1.5.1, No. 1.5.2; No. 1.5.4, No. 1.5.6, No. 1.5.8, No. 1.5.10, No. 1.5.11, No. 1.5.13

The partly completed machinery may not be put into operation until it has been confirmed that the machine into which the partly completed machinery is to be installed complies with the provisions of the Machinery Directive (2006/42/EC). The declaration shall be rendered invalid if modifications are made to the product.

Applied harmonized standards, especially:

EN ISO 12100:2010 Safety of machinery – General principles for design –
Risk assessment and risk reduction

The special technical documentation according to Annex VII, Part B, belonging to the partly completed machine, has been created.

Person authorized to compile the technical documentation:
Stefanie Walter, Address: see manufacturer's address

Signature: see original declaration

Lauffen/Neckar, October 2023

Dr.-Ing. Manuel Baumeister,
Head of Systems Engineering,
Technology & Innovation

11 UKCA declaration of Conformity

Manufacturer/
Distributor SCHUNK Intec Limited
 Clamping and gripping technology
 3 Drakes Mews, Crownhill
 MK8 0ER Milton Keynes

We hereby declare on our sole authority that the product meets the requirements of the following directives at the time of the declaration.

The declaration is rendered invalid if modifications are made to the product.

Product designation: Gripper for small components EGI
ID number 1328833, 1328834, 1328836, 1328837, 1328835, 1328838

- **Electromagnetic Compatibility Regulations 2016**

Applied harmonized standards, especially:

EN IEC 61000-6-2:2019 Electromagnetic compatibility (EMC) – Part 6-2:
 Generic standards – Immunity standard for industrial environments

EN IEC 61000-6-4:2019 Electromagnetic compatibility (EMC) – Part 6-4:
 Generic standards – Emission standard for industrial environments

Person authorized to compile the technical documentation:
Marcel Machado, address: refer to manufacturer's address

Signed for and on behalf of: SCHUNK SE & Co. KG



Lauffen/Neckar, October 2023

Dr.-Ing. Manuel Baumeister, Head of Systems
Engineering, Technology & Innovation

12 UKCA declaration of incorporation

in accordance with the Supply of Machinery (Safety) Regulations 2008.

Manufacturer/	SCHUNK Intec Limited
Distributor	Clamping and gripping technology 3 Drakes Mews, Crownhill MK8 0ER Milton Keynes

We hereby declare that on the date of the declaration the following partly completed machine complied with all basic safety and health regulations found in the "Supply of Machinery (Safety) Regulations 2008".

The declaration shall be rendered invalid if modifications are made to the product.

Product designation:	Gripper for small components / EGI / electric
ID number	1328833, 1328834, 1328836, 1328837, 1328835, 1328838

The partly completed machine may not be put into operation until it has been confirmed that the machine into which the partly completed machine is to be installed complies with the provisions of the "Supply of Machinery (Safety) Regulations 2008".

Applied harmonized standards, especially:

EN ISO 12100:2010	Safety of machinery – General principles for design – Risk assessment and risk reduction
-------------------	---

The special technical documentation according to Annex VII, Part B, belonging to the partly completed machine, has been created.

Person authorized to compile the technical documentation:
Marcel Machado, address: refer to manufacturer's address



Lauffen/Neckar, October 2023

Dr.-Ing. Manuel Baumeister,
Head of Systems Engineering,
Technology & Innovation

13 Information on the RoHS Directive, REACH Regulation and Substances of Very High Concern (SVHC)

RoHS Directive

SCHUNK products are classified as "large-scale stationary installations" or as "large-scale stationary industrial tools" within the meaning of Directive 2011/65/EU and its extension 2015/863/EU "on the restriction of the use of certain hazardous substances in electrical and electronic equipment (RoHS)", or fulfill their intended function only as part of one. Therefore products from SCHUNK do not fall within the scope of the directive at this time.

REACH Regulation

Products from SCHUNK fully comply with the regulations of Regulation (EC) No. 1907/2006 "concerning the Registration, Evaluation, Authorization and Restriction of Chemicals (REACH)" and its amendment 2022/477. SCHUNK attaches great importance to completely avoiding chemicals of concern to humans and the environment wherever possible.

Only in rare exceptional cases do SCHUNK products contain SVHC substances on the candidate list with a mass content above 0.1%. In accordance with Article. 33 (1) of Regulation (EC) No. 1907/2006, SCHUNK complies with its duty to "communicate information on substances in articles" and lists the components concerned and the substances used in an overview that can be viewed at [schunk.com\SVHC](https://www.schunk.com/SVHC).

Signature: see original declaration

Lauffen/Neckar, October 2023

Dr.-Ing. Manuel Baumeister,
Head of Systems Engineering,
Technology & Innovation

14 Appendix

14.1 Commissioning with Siemens "TIA Portal" software for PROFINET

NOTE

The modules support prioritized start-up (FSU – Fast-Start-Up).

1. Start TIA Portal and select "Create new project" (a).
2. Assign project name (b) and specify storage location (c).
3. Click the "Create" (d) button.
4. Follow the instructions of the TIA Portal to create the project completely.
5. After successfully creating the project, click "Project view" (e) at the bottom left to switch to the project view.

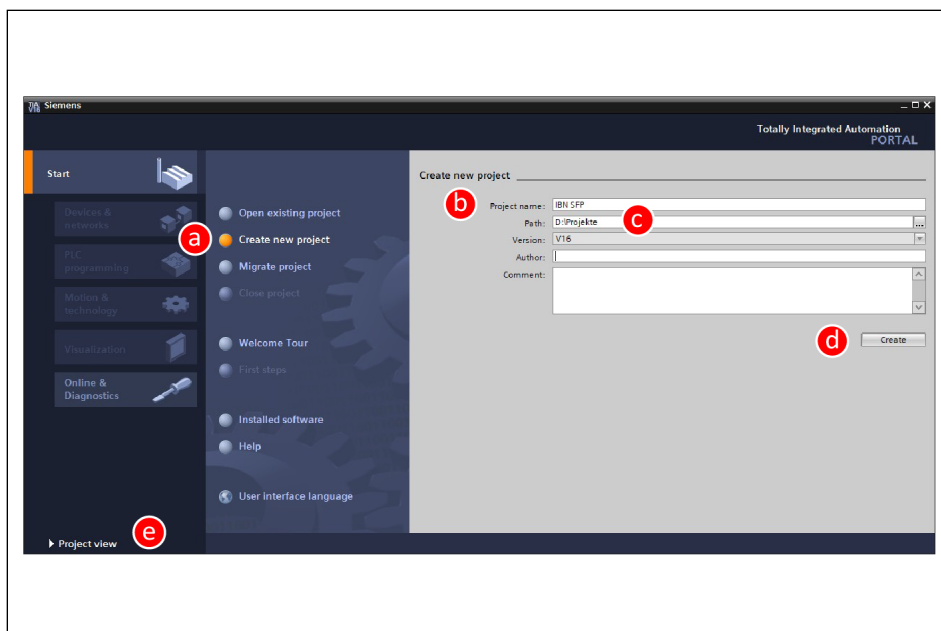

- In the menu bar of the project view, click the "Options" button (a) and then "Manage device description files (GSD)" (b).

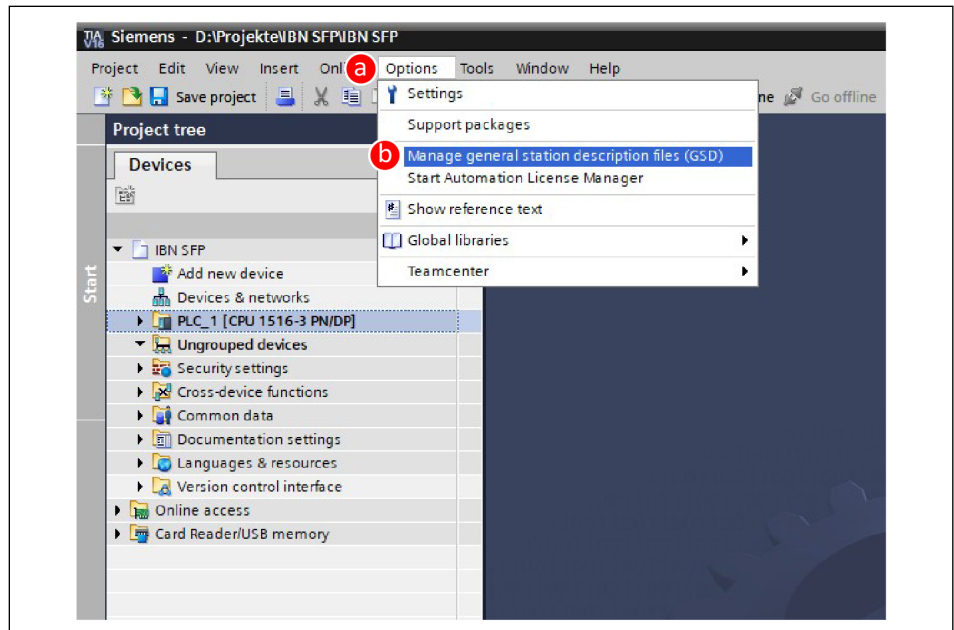

- Select "Source Path" (a) and choose the folder containing the GSDML file to be installed.
- Select the corresponding file (b) and click the "Install" button (c).

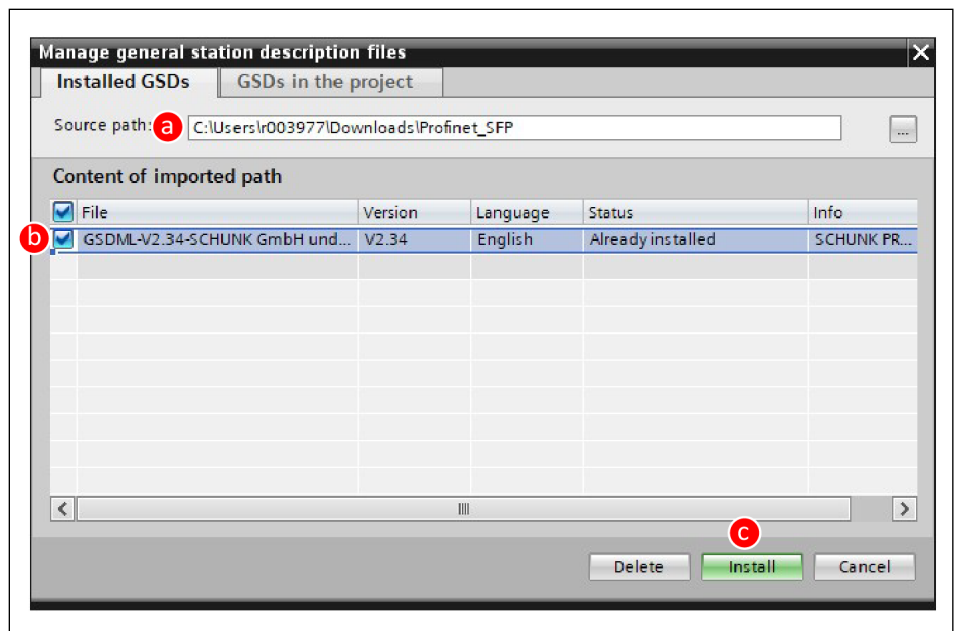

- After completing the installation, switch to "Devices and networks" (a) in the project navigation (left side).

10. In the hardware catalog (right side) in the subitem *Other field devices* > *Profinet IO* > *Drives* > *Schunk GmbH & Co. KG* > *SFP*, select the corresponding device (b) and, if necessary, the correct version (c).
11. Drag and drop the device into the "Network view" window (d).

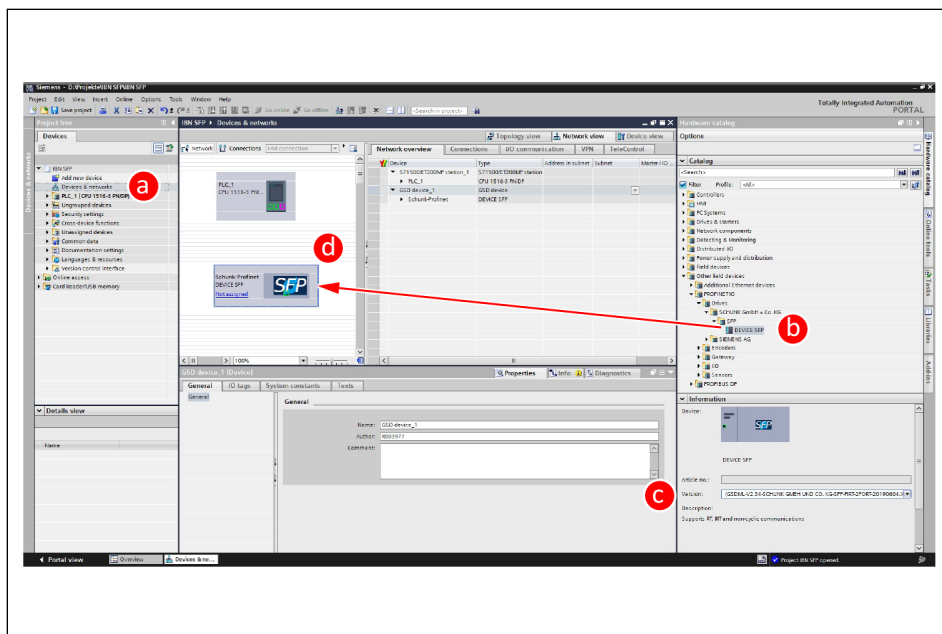

12. Connect device (a) to CPU (b)

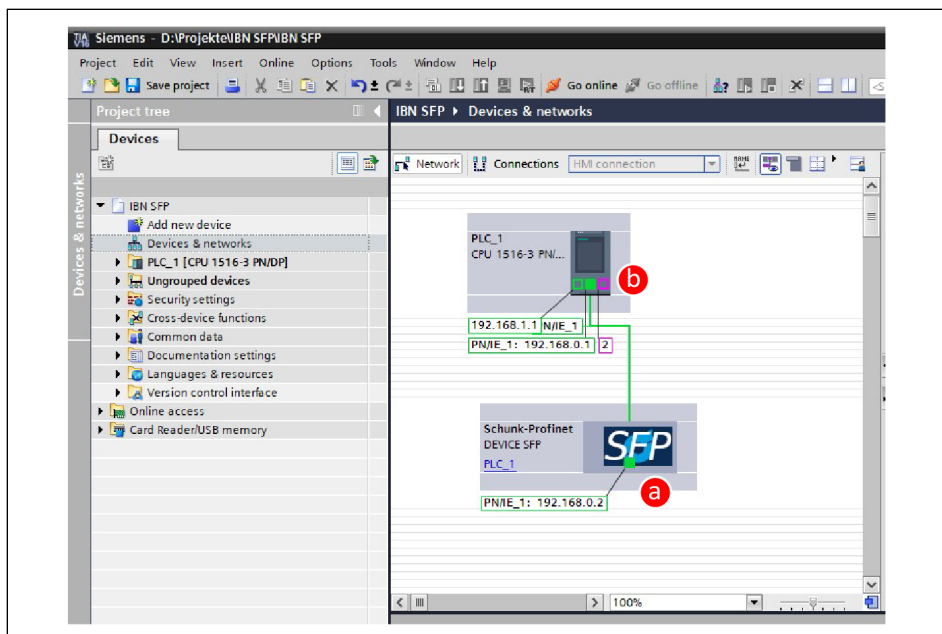

- Open the device overview: To do this, click the device (a) and then "Device view" (b) or double-click on the device (a).

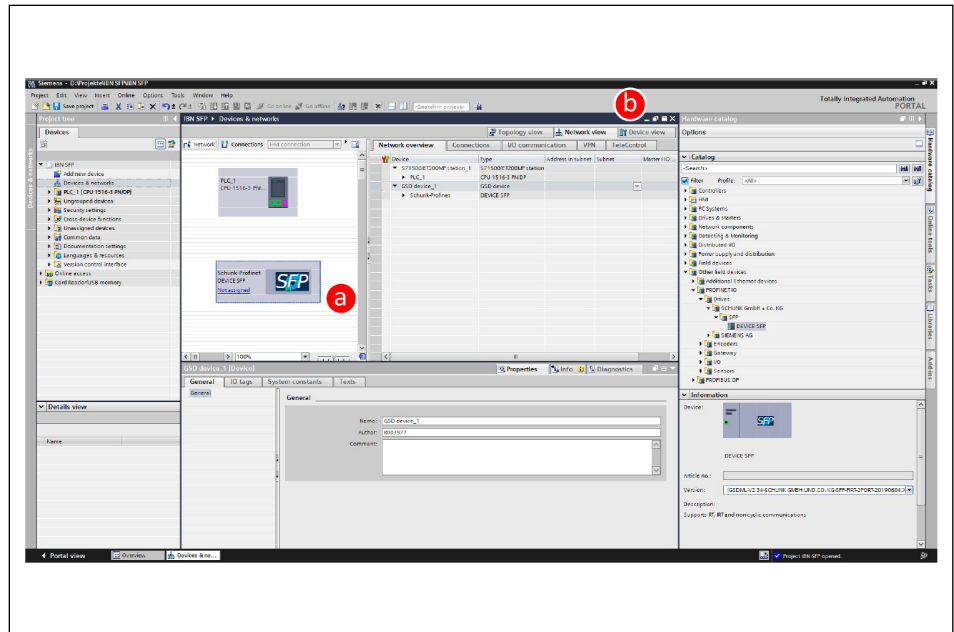

- Change hardware address (a) and device name (b) if necessary.
- Ensure that the device is connected to a programming device via PROFINET and that the logic of the device is supplied with voltage.
- Assign device name: To do this, click the device (c) and then click the "Assign device name" button (d).

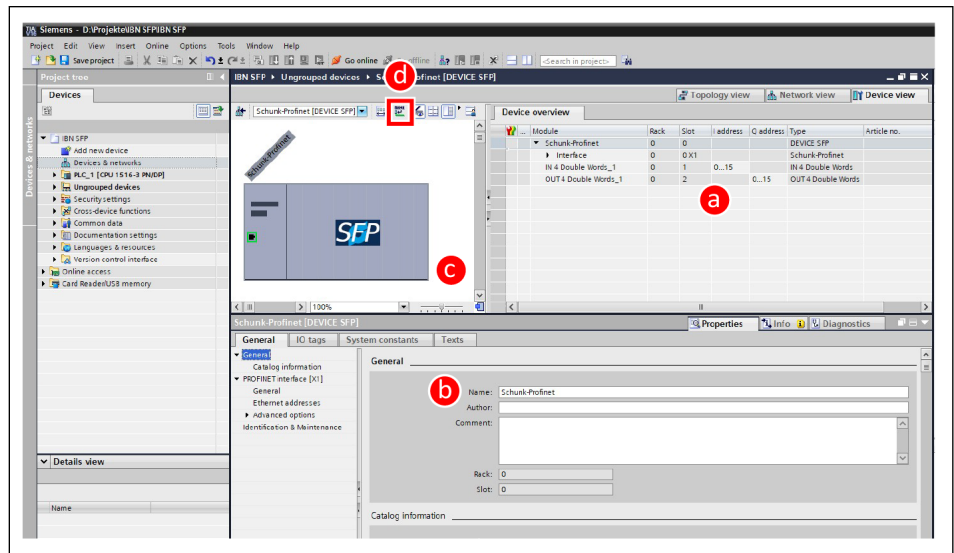

- PROFINET-Select device name (a).
- Select the interface (b) and click the "Update list" button (c).

19. Highlight the device (d) found and click the "Assign name" button (e)

⇒ PROFINET device name (a) has been assigned.

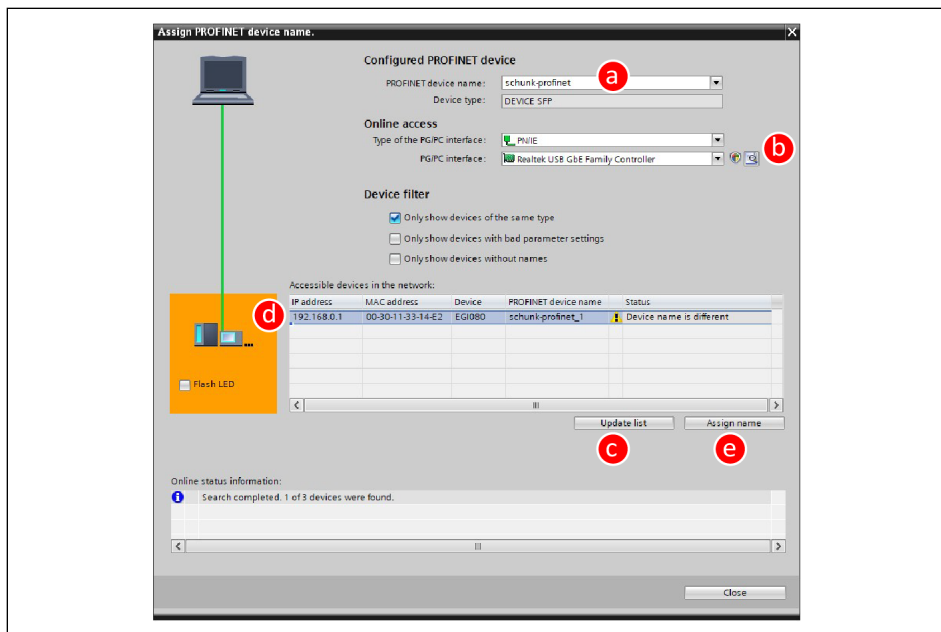

20. Once the PROFINET device name (a) has been assigned successfully, click the "Close" button (b).

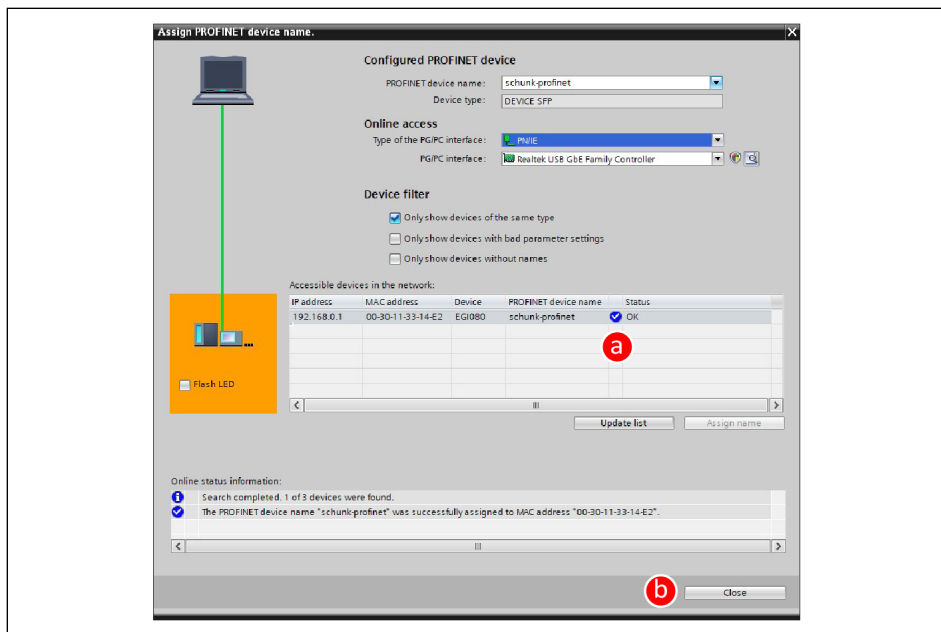

21. Transfer the hardware configuration to the CPU and control the device using a variable table.

14.2 Commissioning with Rockwell "Studio 5000 ®" software for EtherNet/IP™

1. Start Rockwell Software Studio 5000® and click "New Project" (a) to create a new project.

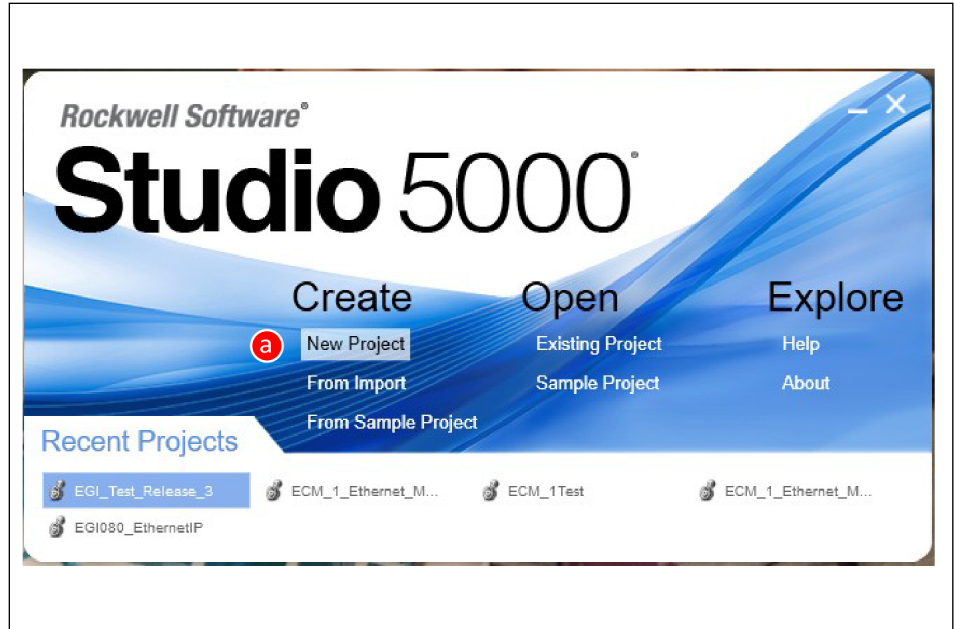

2. In the "New Project" window, select the corresponding control (a). Click "Browse" (b).

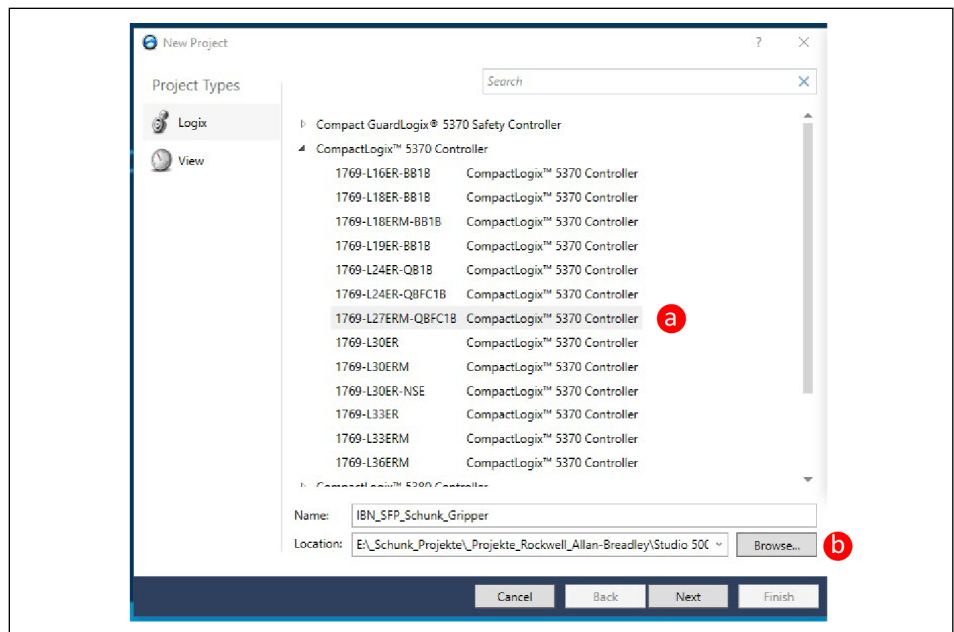

⇒ A window appears.

3. Create folder for project storage (a).
4. Click the "OK" button (b).

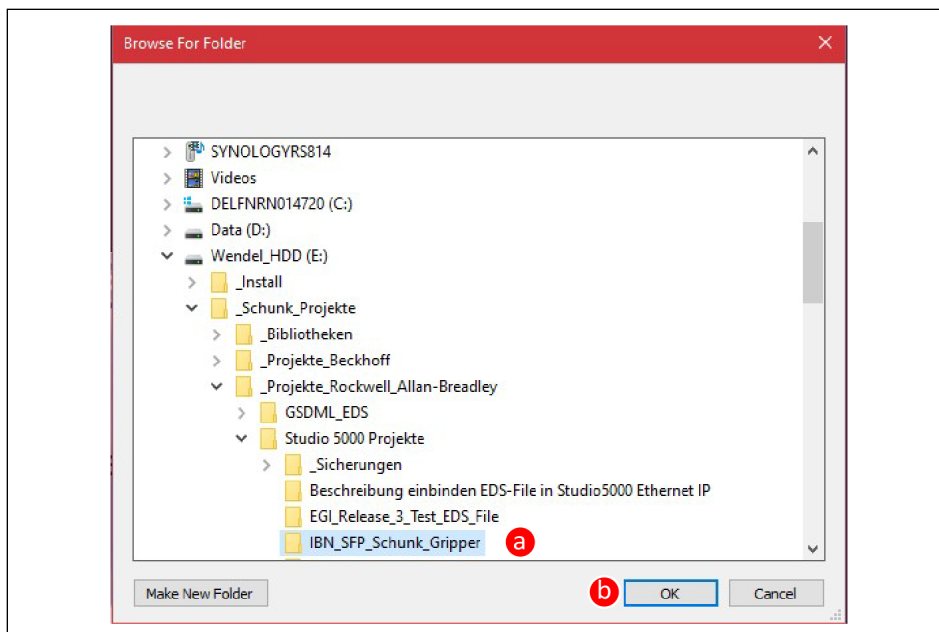

⇒ The "New Project" window opens.

5. Click the "Next" button to go to the next query.
6. Click the "Finish" button (a).

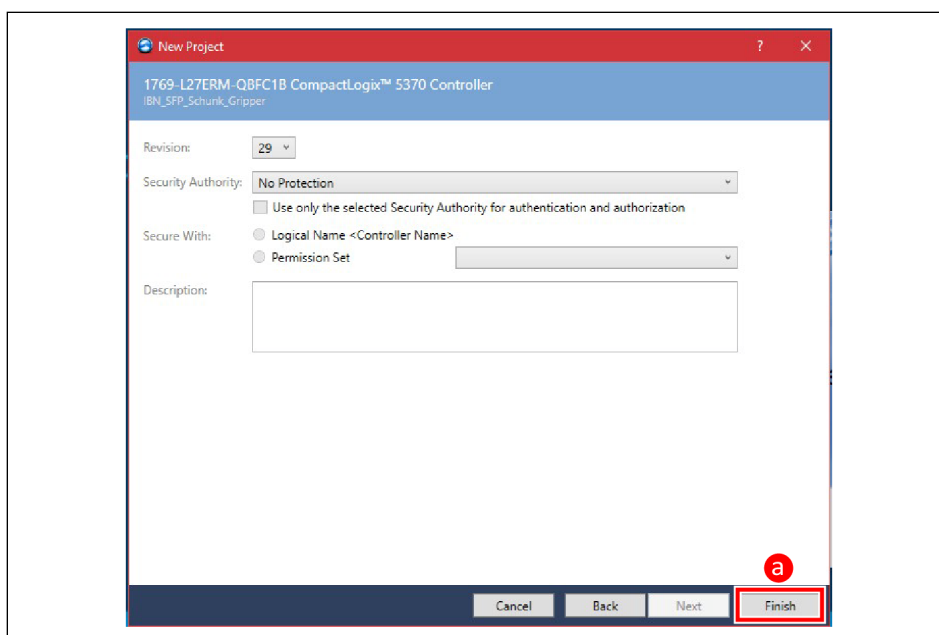

⇒ The project is created.

- Click the "Tools" button (a) in the menu bar and then click "EDS Hardware Installation Tool" (b) to start this tool.

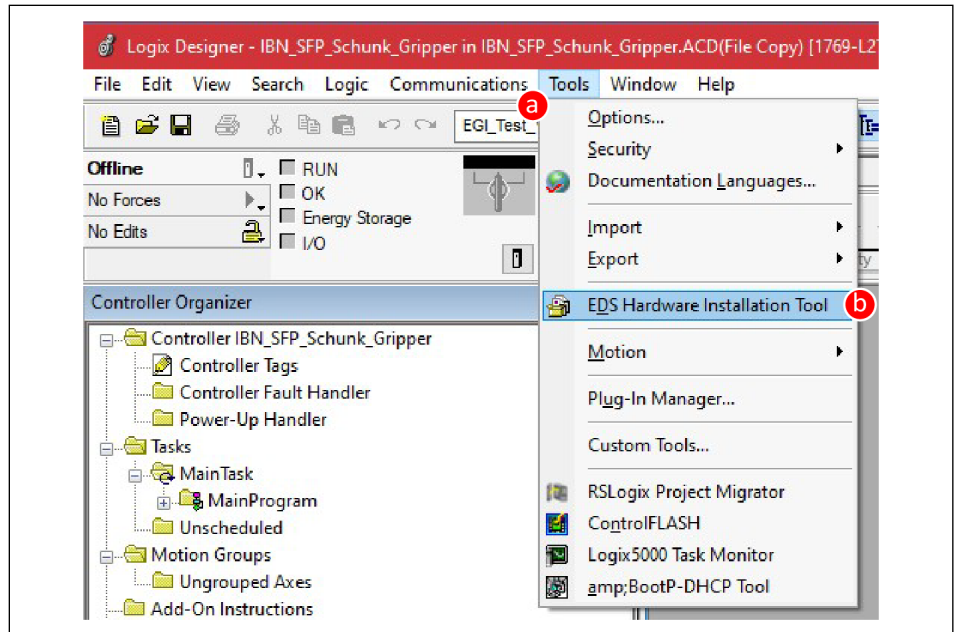

- Register the new EDS file (a) and click the "Next" button (b).

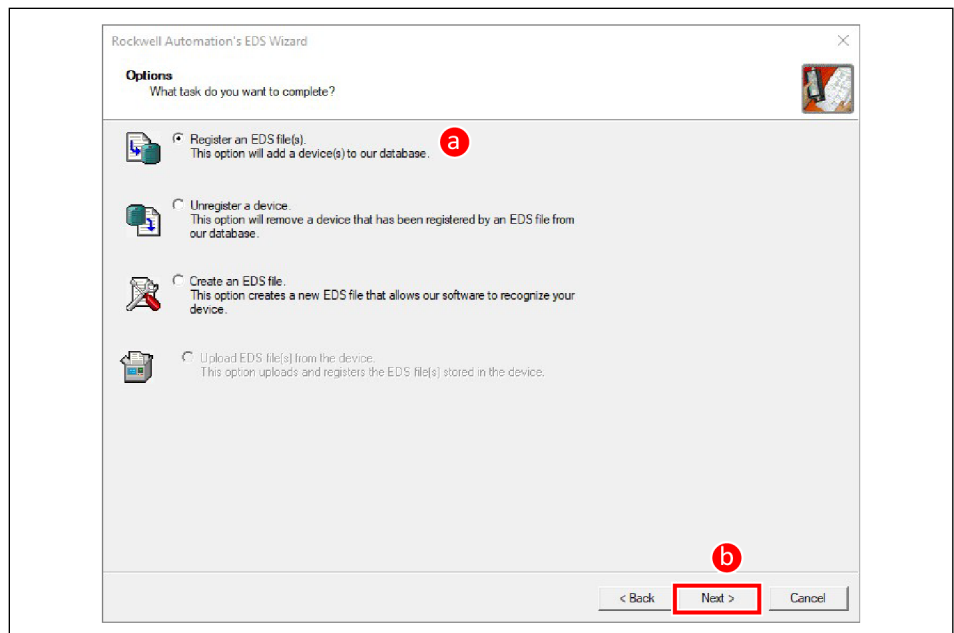

9. Select the folder containing the file (a) to be registered.
10. Select the corresponding file (b) and click the "Open" button (c).

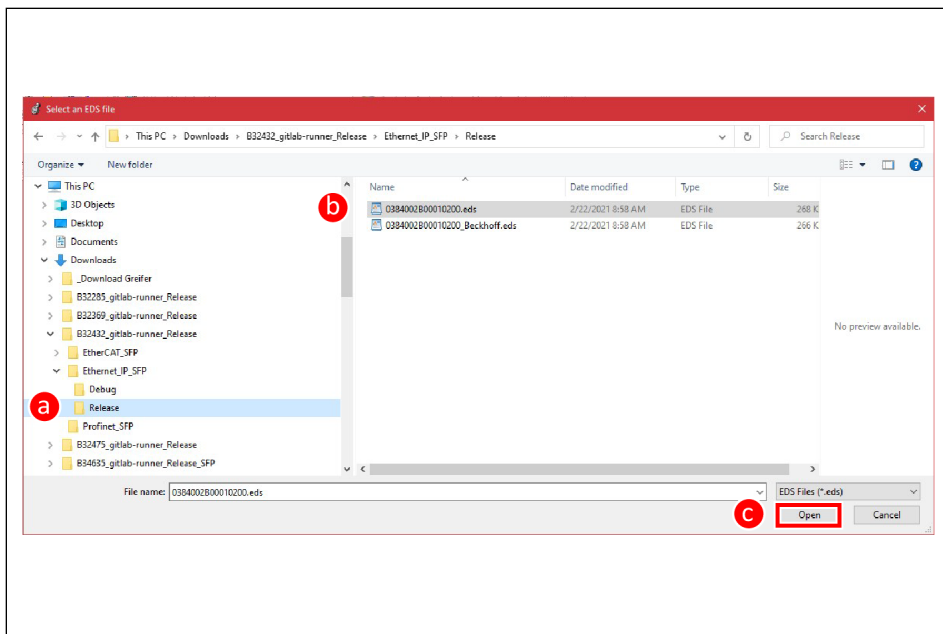

11. Select "Register a single file" (a) and follow the additional instructions from the installation wizard.

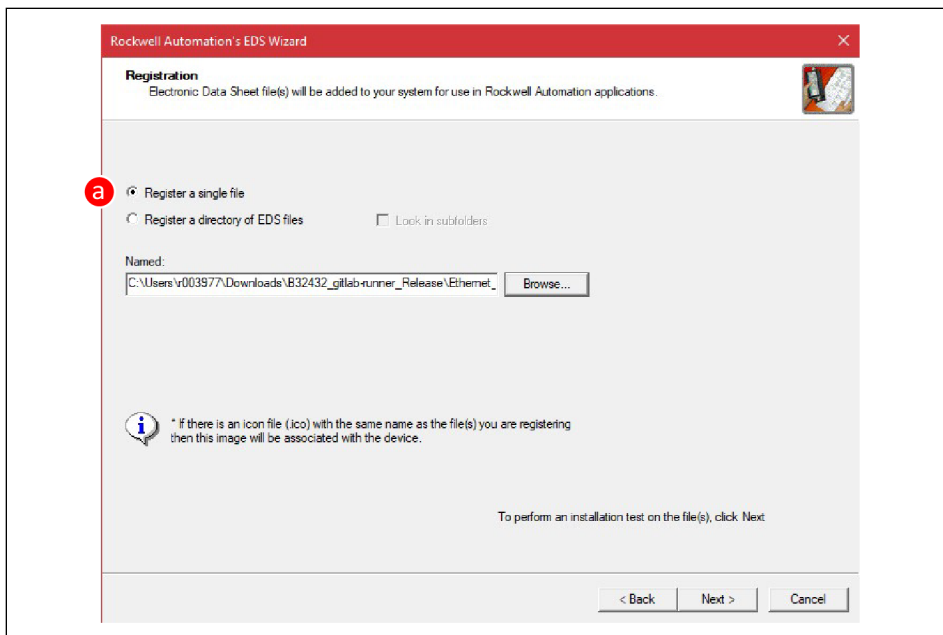

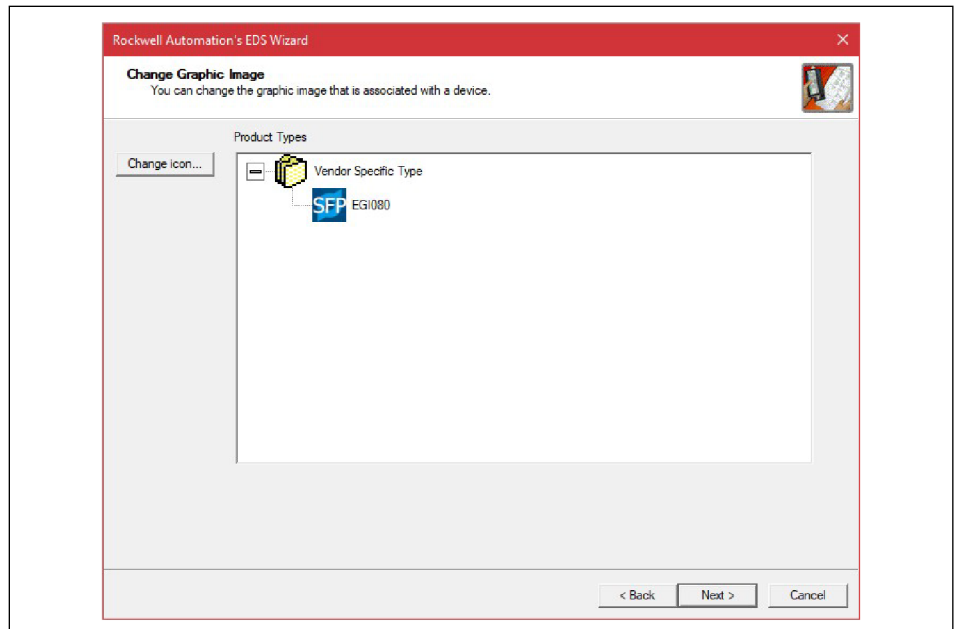
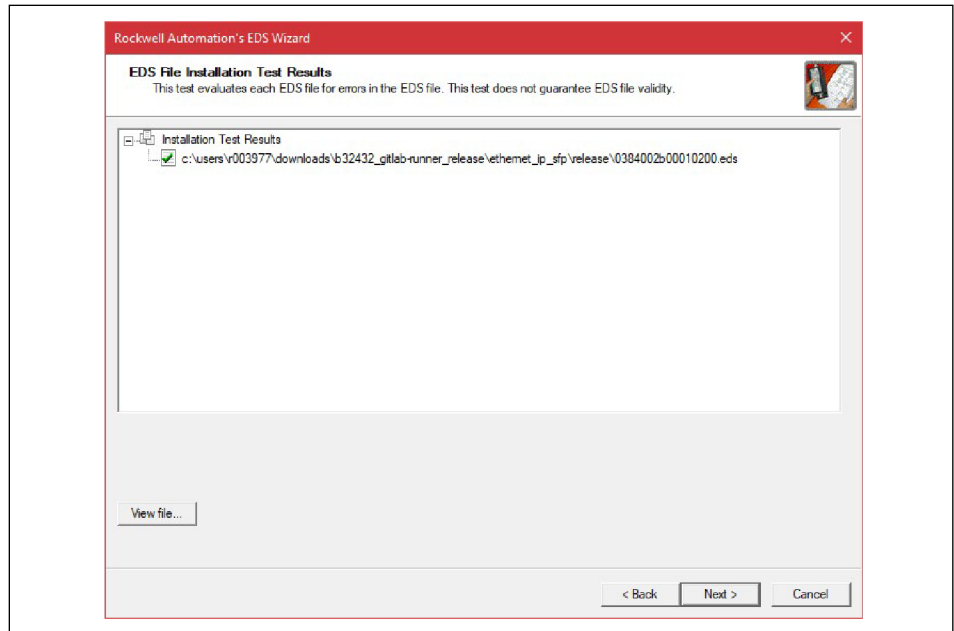

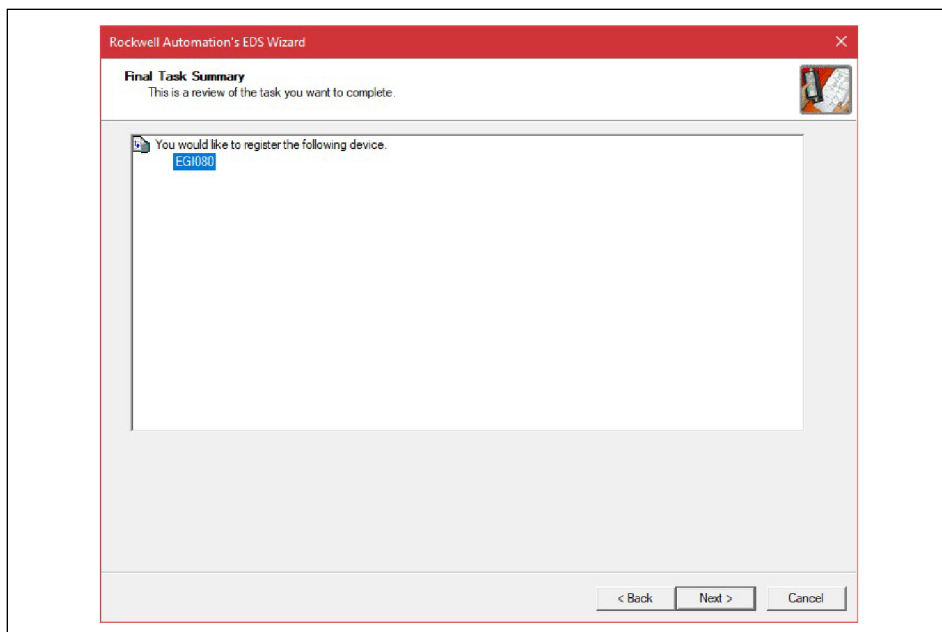

12. Click the "Finish" button (a) to complete the installation.

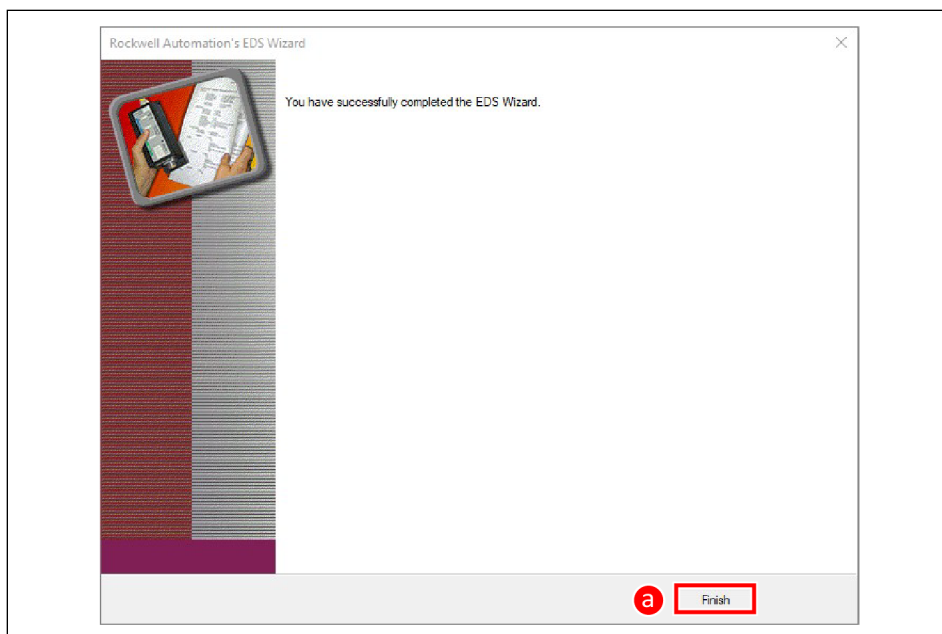

13. In the "Controller Organizer" (left side) under *I/O Configuration > EtherNet*, insert a new module by right-clicking (a).

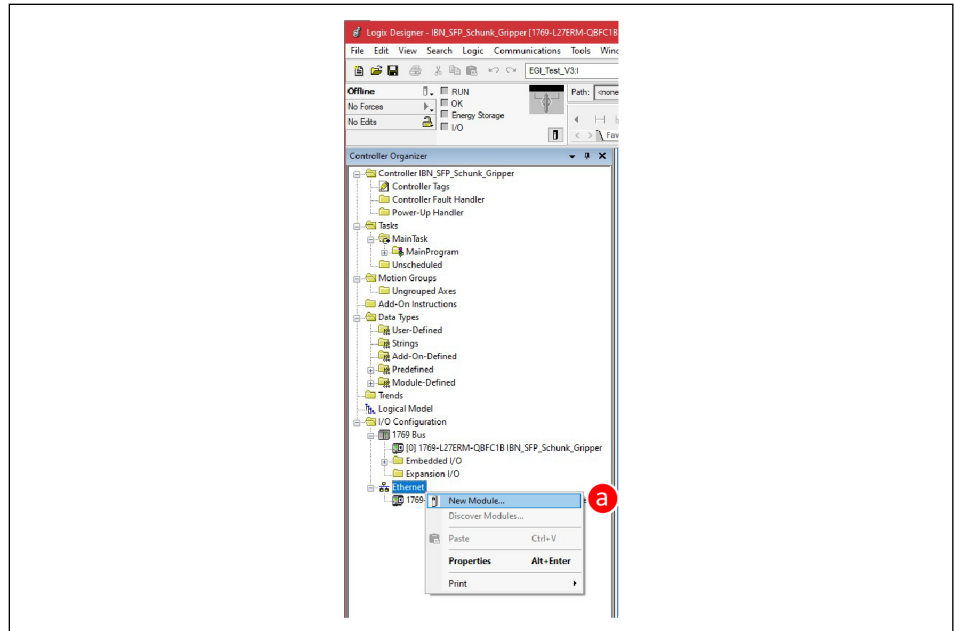

⇒ A window with a selection catalog opens.

14. In the "Catalog" tab, enter "Schunk" in field (a).

⇒ The catalog is filtered by the device you are searching for.

15. Select the appropriate device and double-click *or* click the "Close" button (b) to confirm the selection.

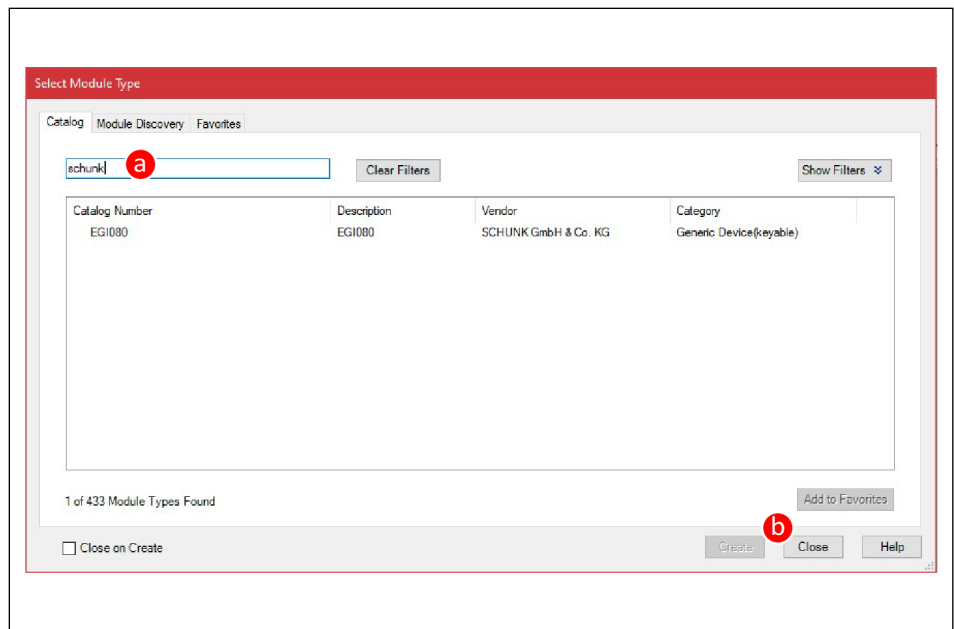

- 16. Assign a device name (a) and an IP address (b).
- 17. Click the "Change" button (c) to configure additional settings.

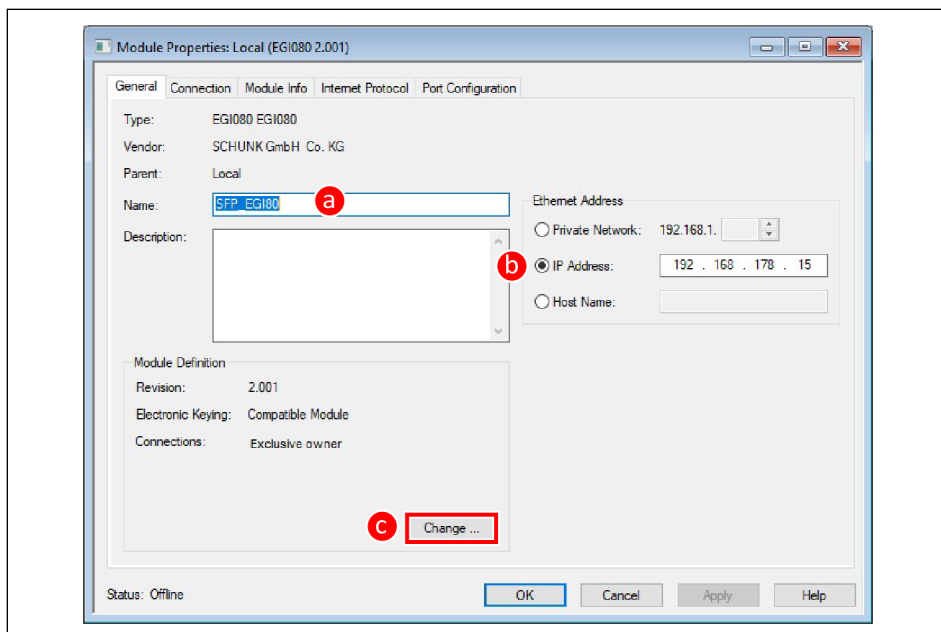

- 18. Change data size from "SINT" to "DINT" (a).
- 19. Click the "OK" button (b) to confirm the selection.

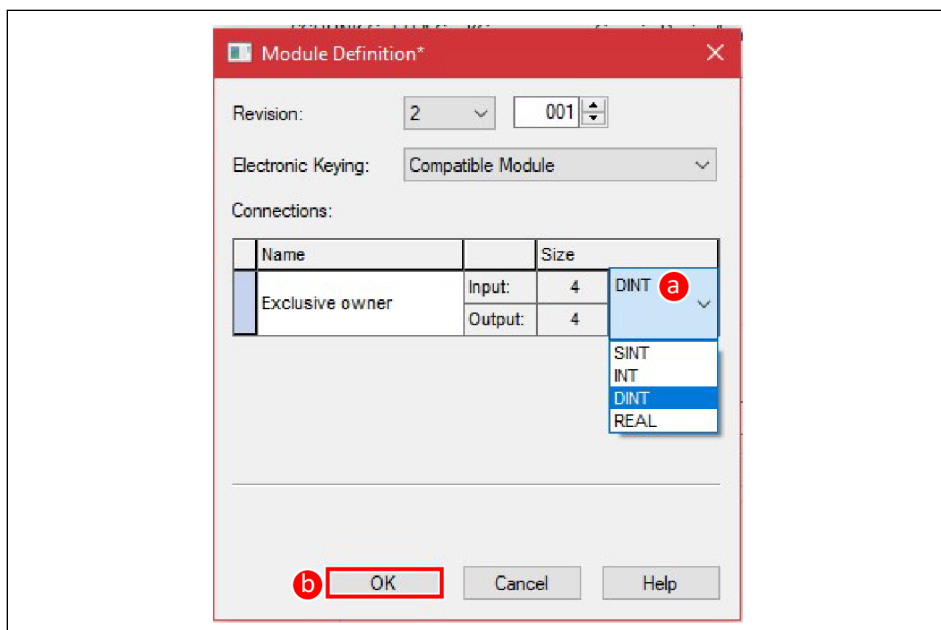

- 20. Transfer the program to the controller and start programming the device.

14.3 Commissioning with Beckhoff "TwinCAT 3 ®" software for EtherCAT

1. Copy the XML file (a) into the intended directory (b).

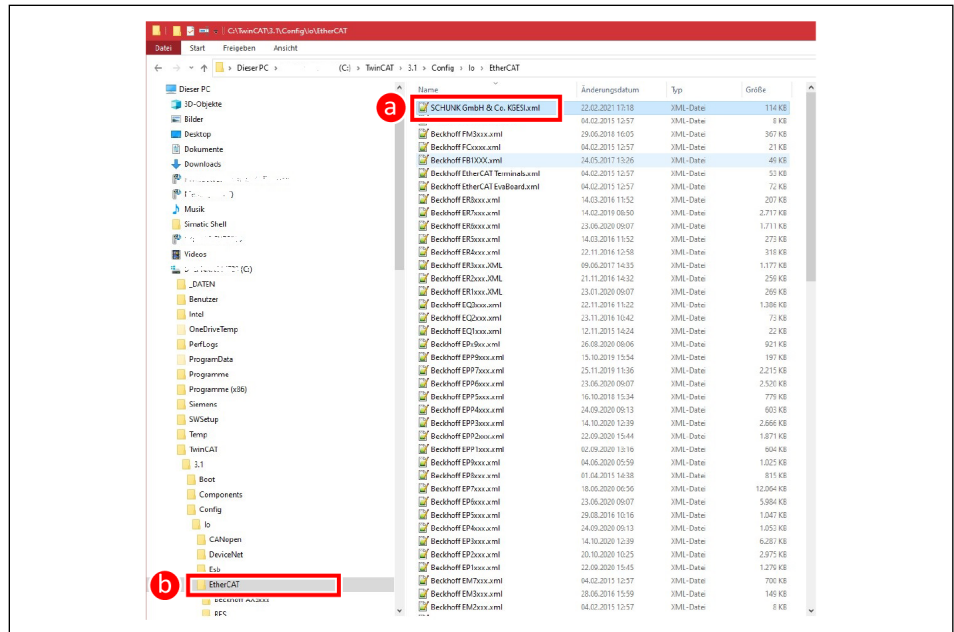

2. Start TwinCAT® 3 and click "New TwinCAT Project" (a) to open the window for creating a new project.

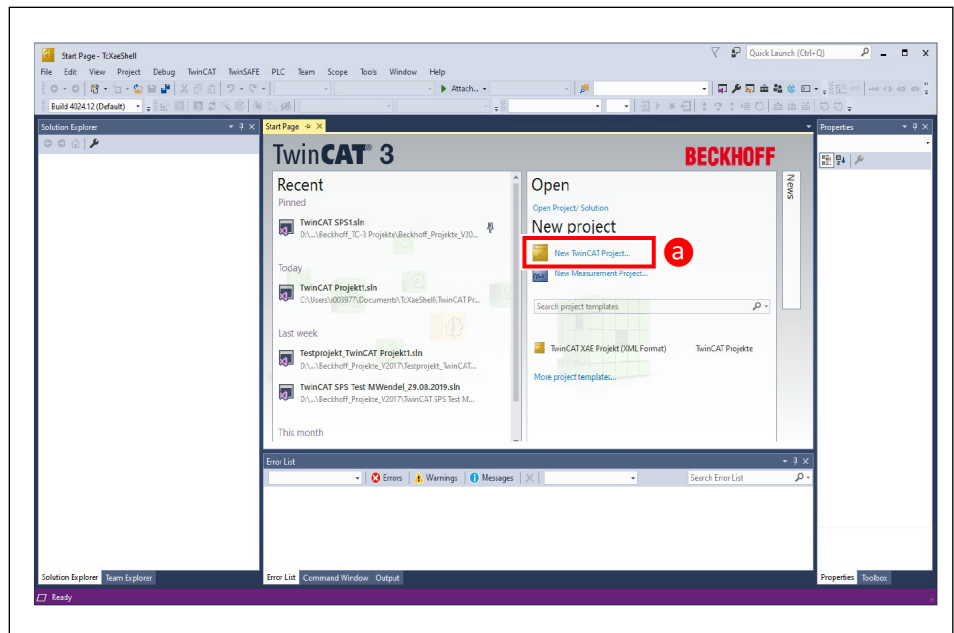

3. Select "TwinCAT Projects" (a).
4. Change name (b), storage location (c) and project folder name (d) as required.
5. Click the "OK" button (e) to create the project.

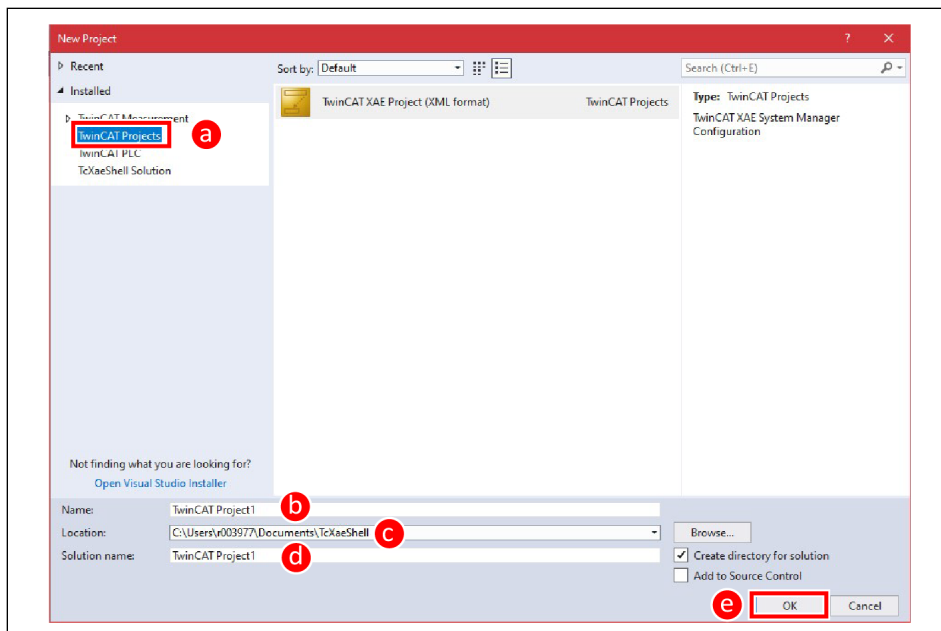

6. In the Solution Explorer (left side) in the subitem // 0 > Devices > Device 1 (EtherCAT), add a new device (a) by right-clicking.

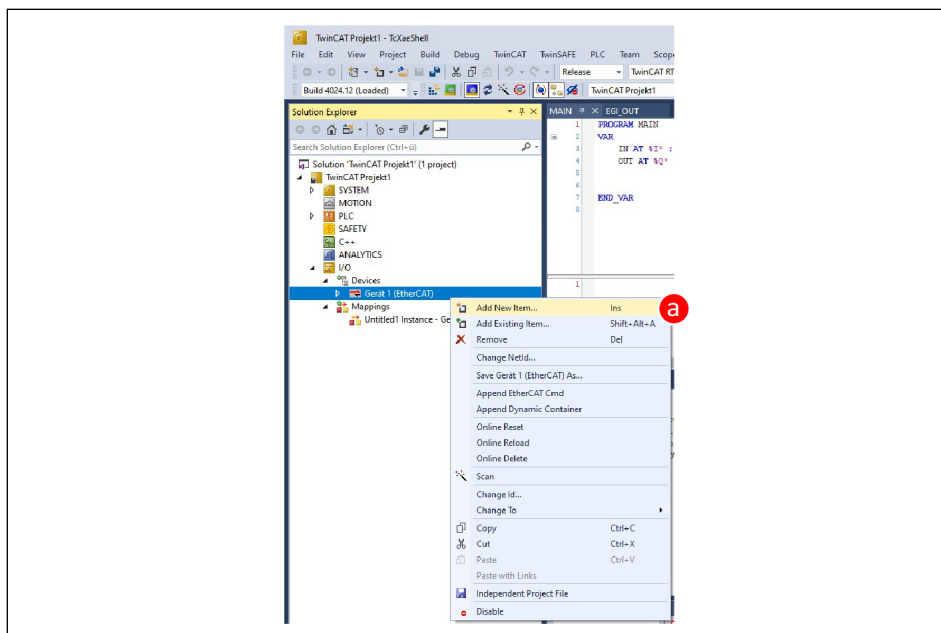

7. Select the appropriate device from the catalog under *Schunk GmbH & Co. KG > Gripper* (a).
8. Click the "OK" button (b) to confirm the selection.

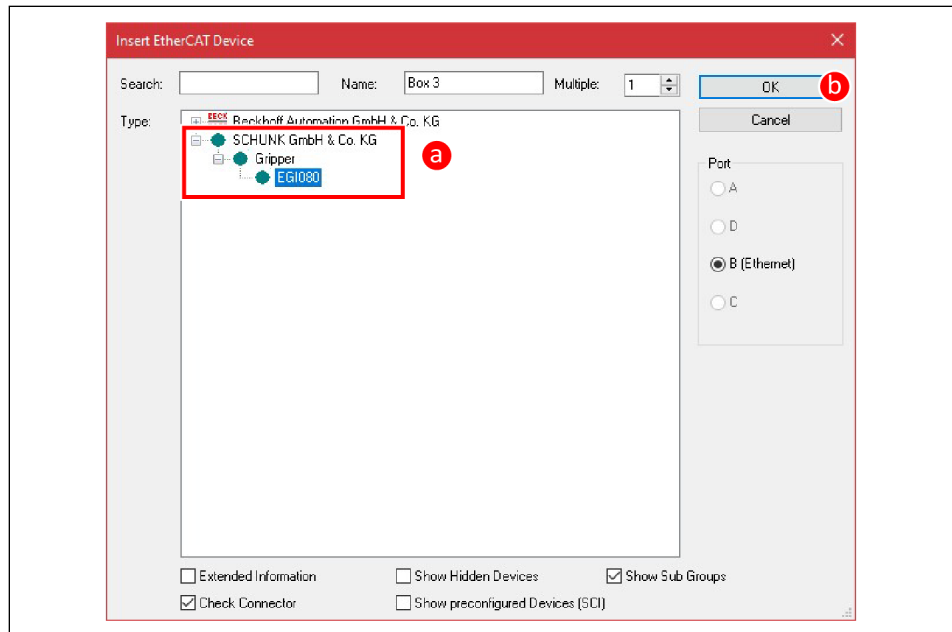

⇒ The added device is displayed in the Solution Explorer (left side) under *Device 1 (EtherCAT)* as "Box 1" (a).

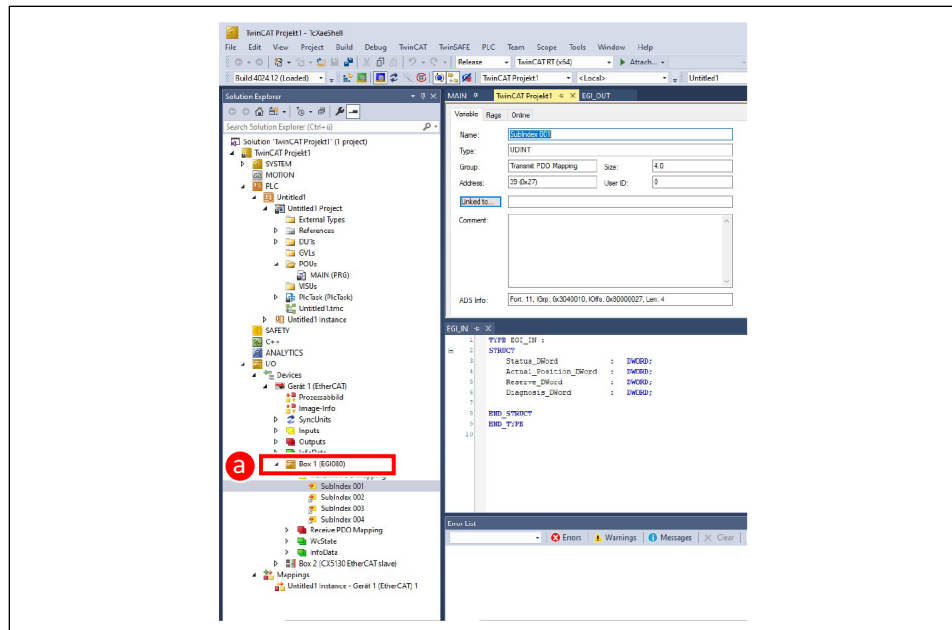

9. In the Solution Explorer, right-click the subitem *PLC > . . . > DUTs* (a) to open a menu.
10. Click "DUT" under "Add".
 - ⇒ A new window appears.
11. Create the necessary variable structures to connect the hardware with the software structures. When creating the variables, make sure that the same variable lengths are used. In the case of the SCHUNK protocol, these are "double words".

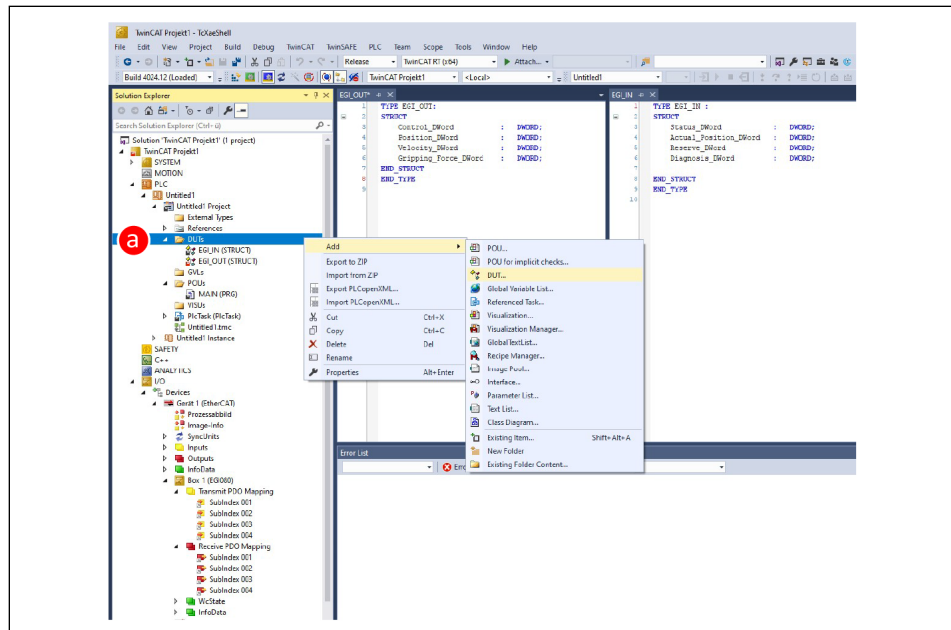

12. Link DUTs as variables in the main program.

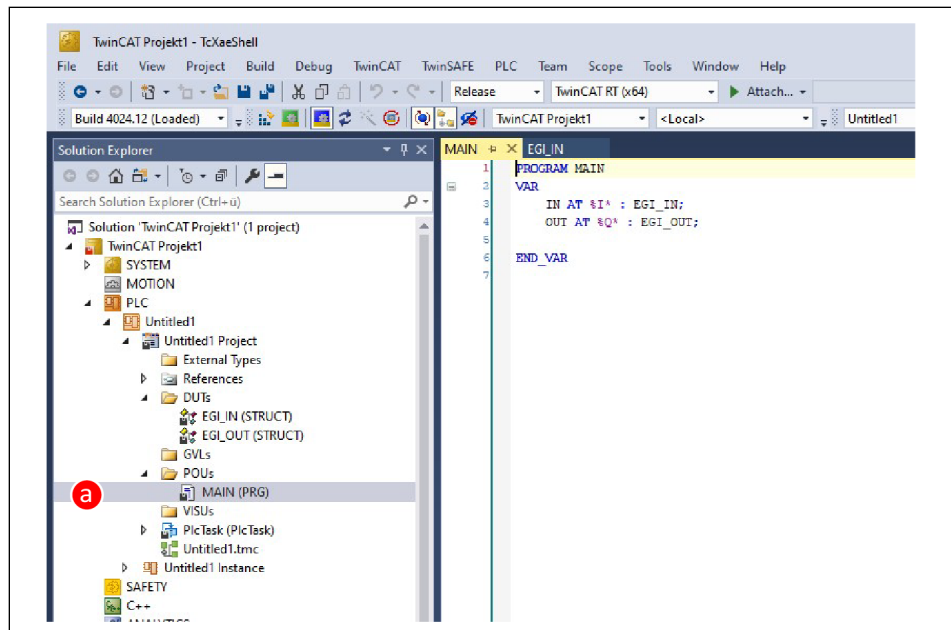

13. A menu opens after right-clicking the subitem *PLC > . . . > DUTs* (a) in the Solution Explorer.
14. Under "Add" click "Razupaltuff".
⇒ A new window appears.
15. Create the necessary variable structures to connect the hardware with the software structures. When creating the variables, make sure that the same variable lengths are used. In the case of the SCHUNK protocol, these are "double words".

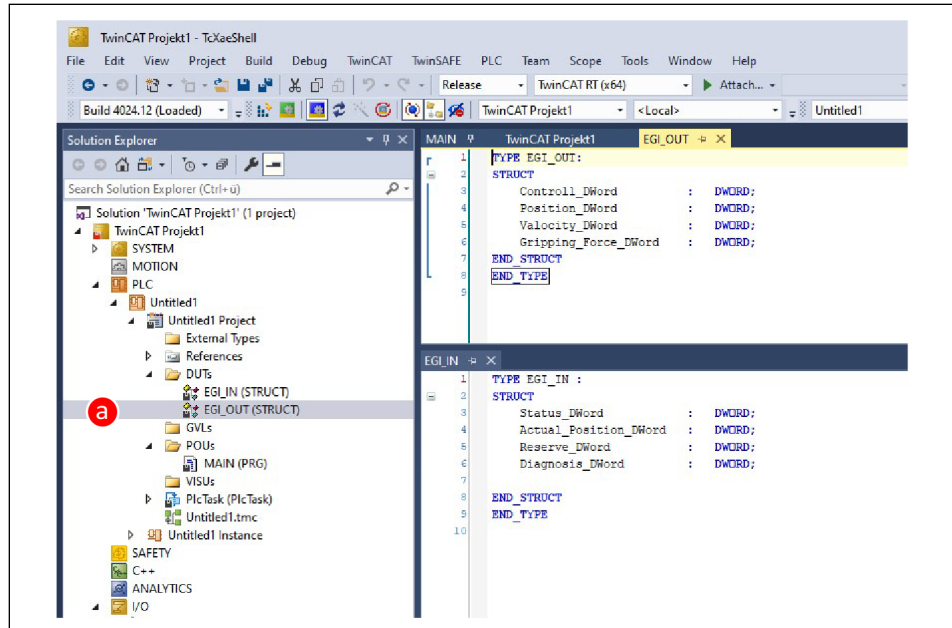

16. Double-click subindex (a) or select "Change link" (b) after right-clicking the subindex.

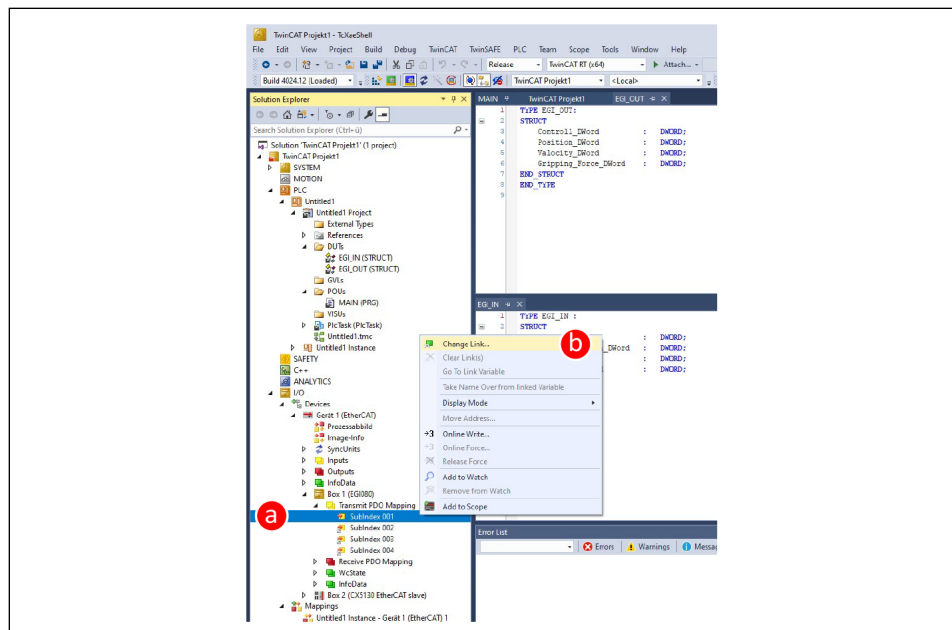

- ⇒ A window for the corresponding subindex opens.
- 17.** Click "Linked m." (a).
- ⇒ A selection window appears.
- 18.** Assign appropriate variables to the hardware.
- 19.** Click the "OK" button.

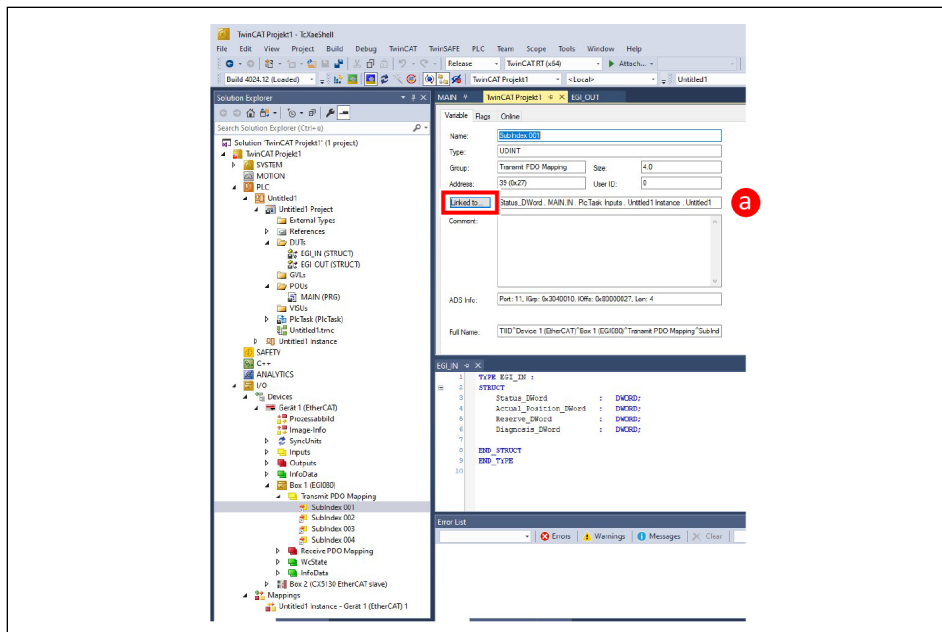

- 20.** Transfer the program to the controller and start programming the device.

14.4 Download the Anybus-IP Config tool

Method 1: Download via direct link

1. Go to the website at <https://www.anybus.com/support/file-doc-downloads/anybus-support-tools?orderCode=tools>.
⇒ The "Files and Documentation" website opens.
2. Click Download under "HMS IPconfig – Utility for module TCP/IP configuration" to start the download.

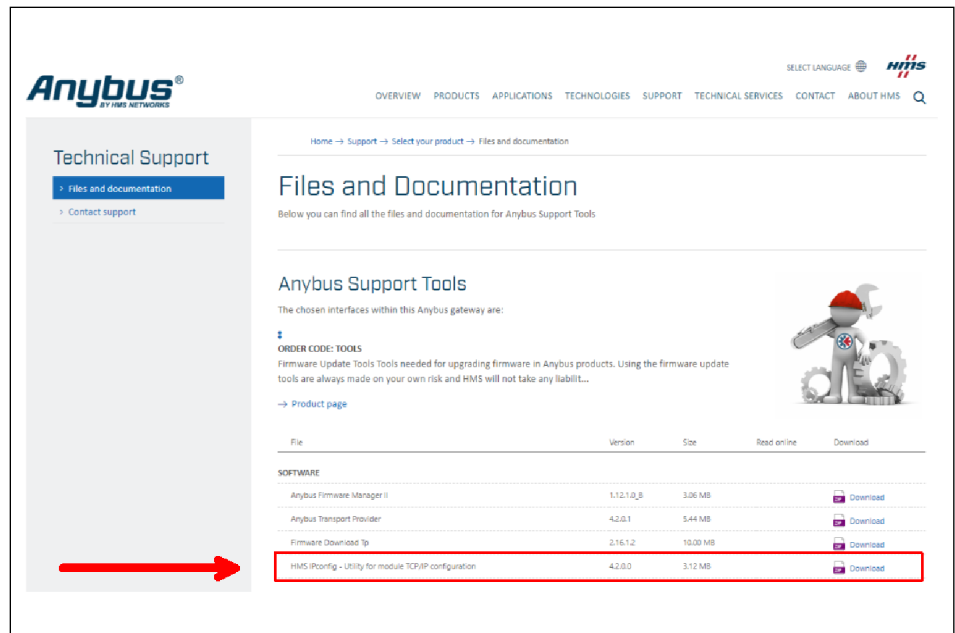

Method 2: Alternatively search for the tool on the Internet, if method 1 does not work

1. Search the Internet using the search term "*hms ipconfig - utility for module tcp/ip configuration*".
2. Select the first search result listed (HMS IPconfig – Anybus).

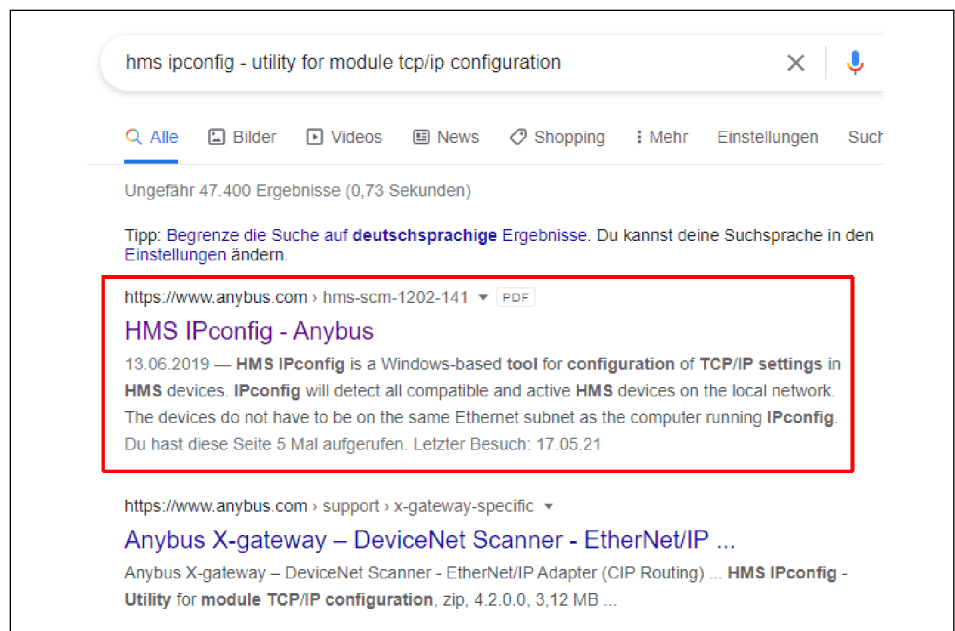

⇒ A PDF file (USER MANUAL – HMS IPconfig) opens.

3. In the "Installation" section, click on the "www.anybus.com/support" link.

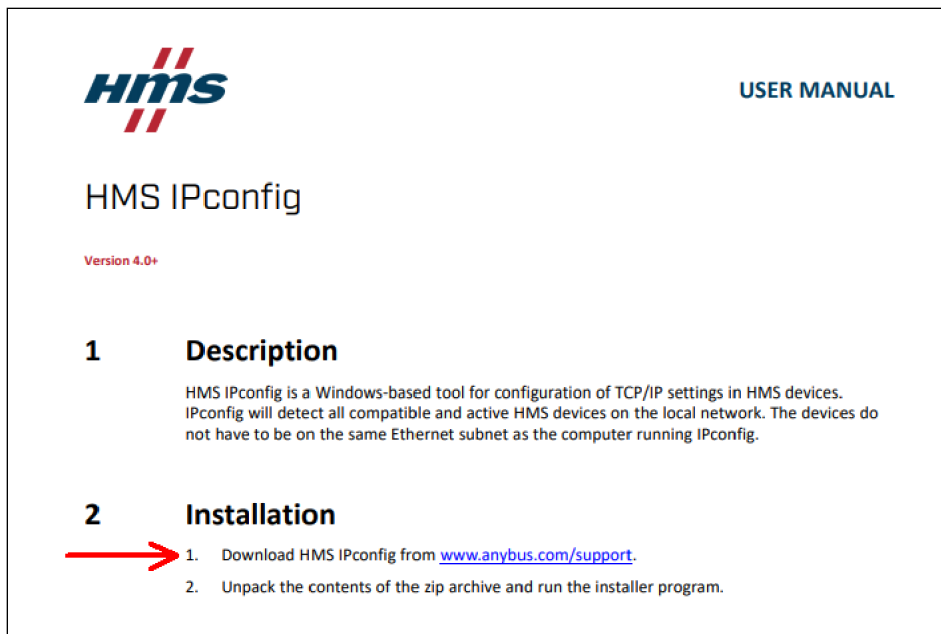

⇒ The "Technical Support" website opens.

4. Select "Embedded Solution".



5. Click "Anybus Support Tools".

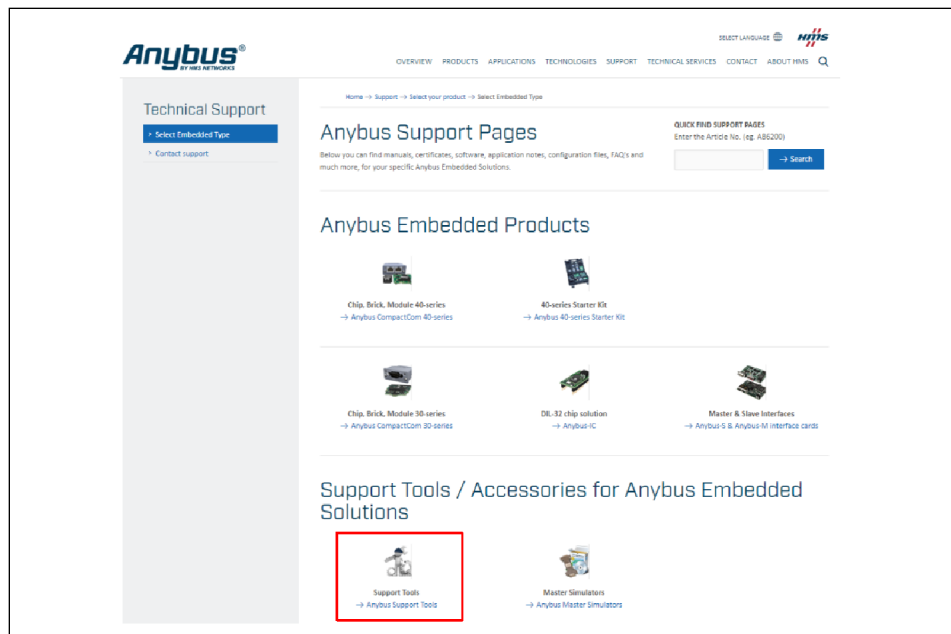

⇒ The "Files and Documentation" website opens.

6. Click Download under "HMS IPconfig – Utility for module TCP/IP configuration" to start the download.

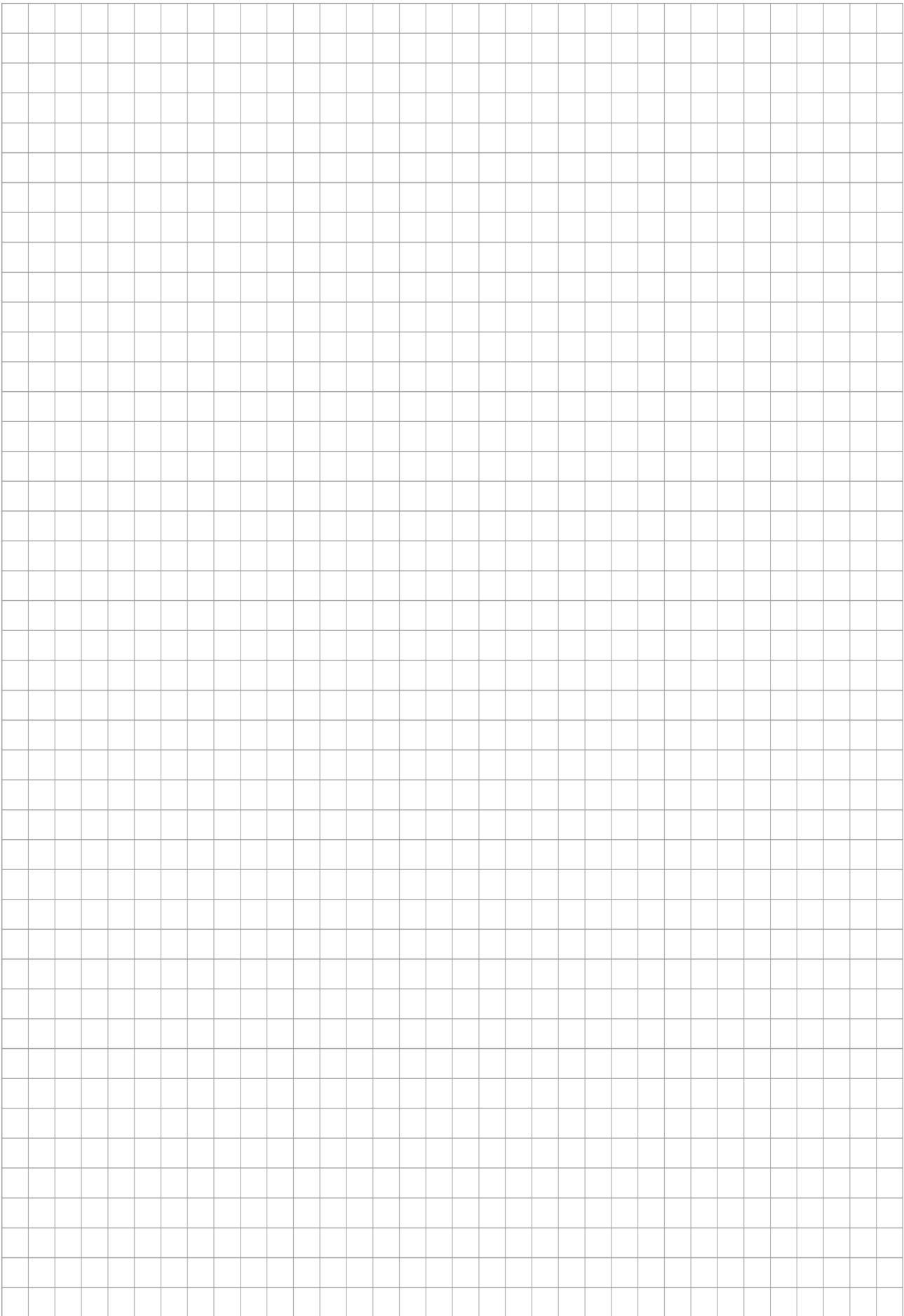

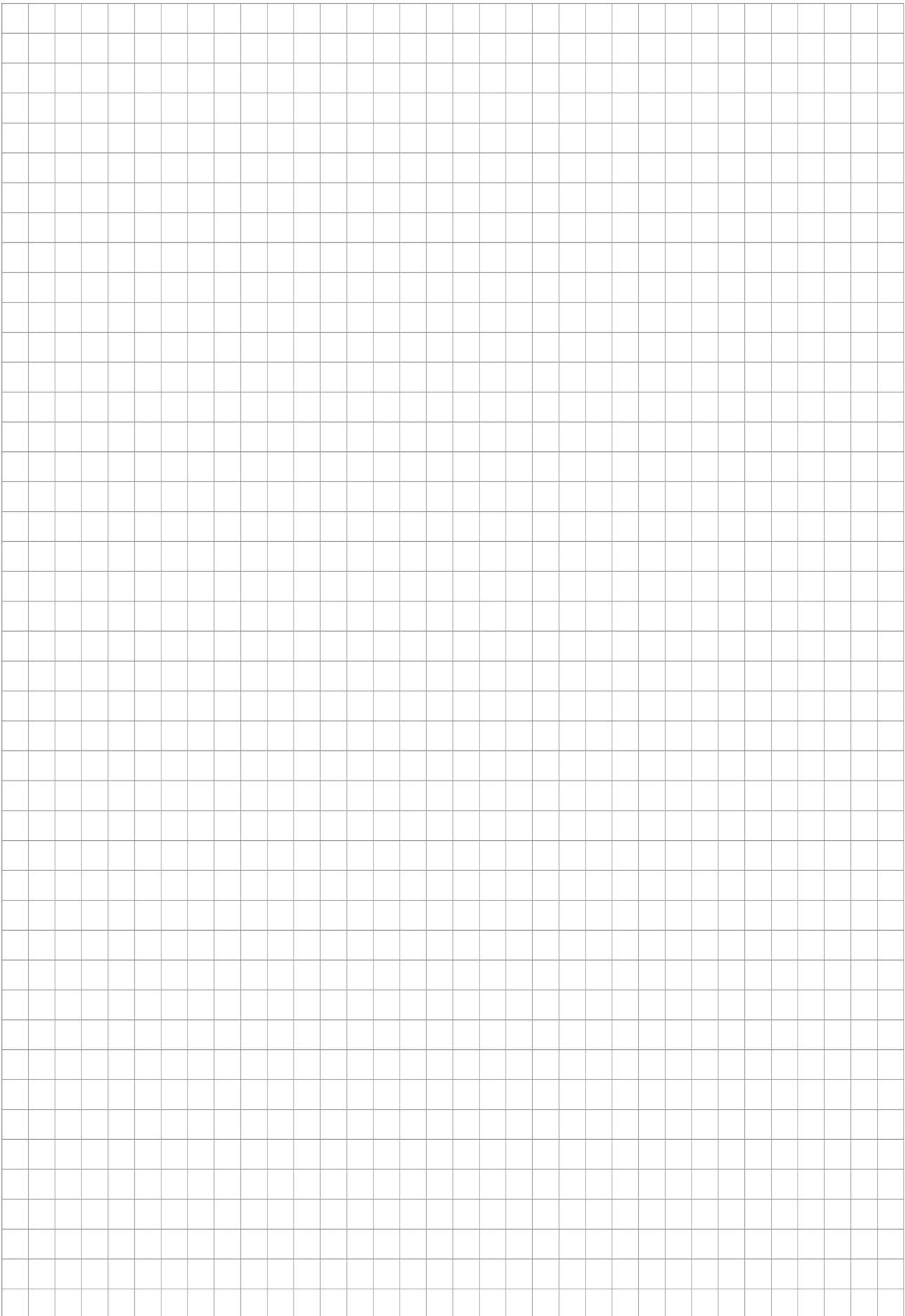

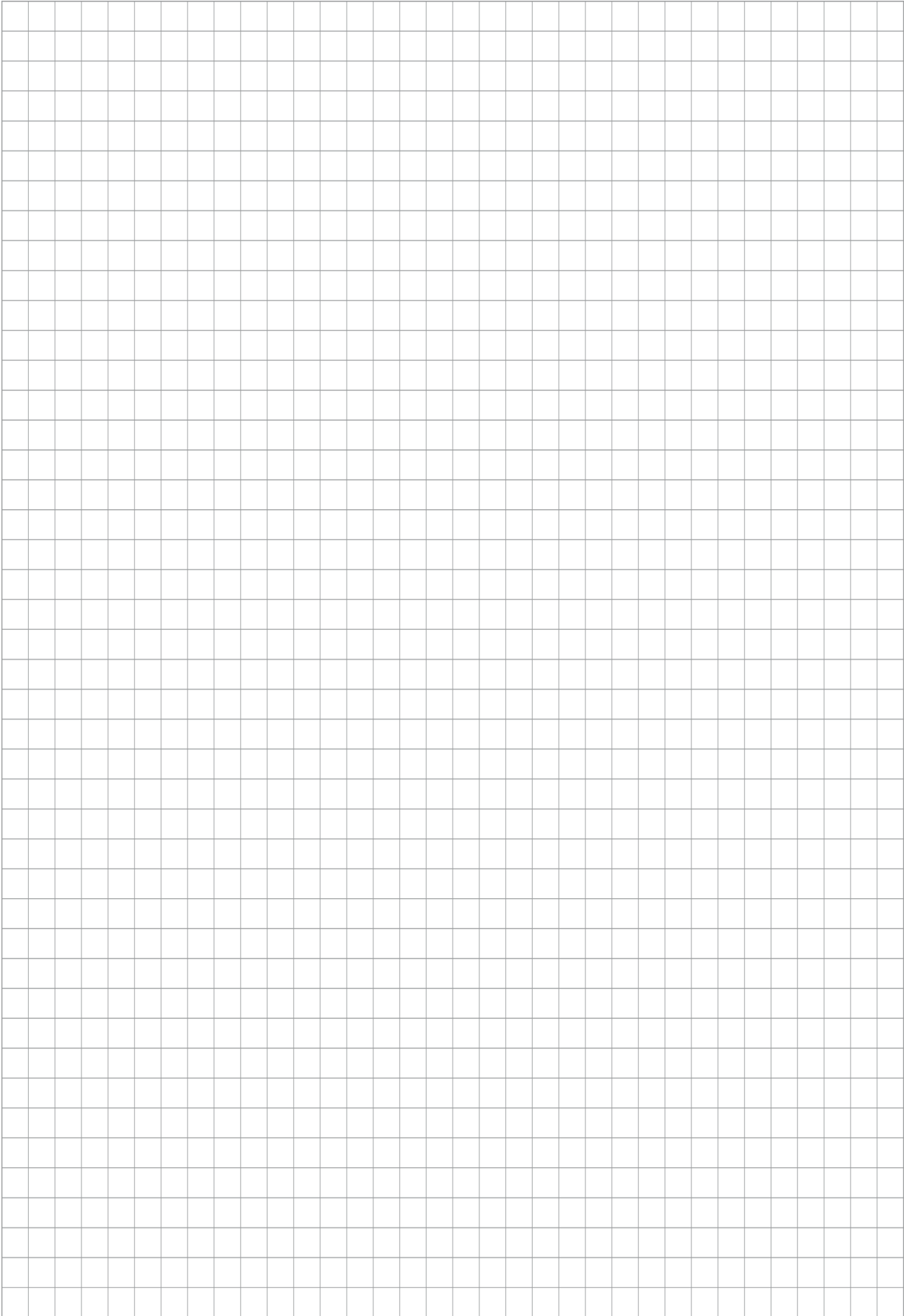



SCHUNK SE & Co. KG
Toolholding and Workholding | Gripping Technology |
Automation Technology

Bahnhofstr. 106 – 134
D-74348 Lauffen/Neckar
Tel. +49-7133-103-0
info@de.schunk.com
schunk.com

Folgen Sie uns | *Follow us*



Wir drucken nachhaltig | *We print sustainable*