



Assembly and Operating Manual

CRT

Compliant Reciprocating Tool

Translation of Original Operating
Manual

Imprint

Copyright:

This manual is protected by copyright. The author is SCHUNK SE & Co. KG.
All rights reserved.

Technical changes:

We reserve the right to make alterations for the purpose of technical improvement.

Document number: 1453513

Version: 05.00 | 20/02/2025 | en

Dear Customer,

Thank you for trusting our products and our family-owned company, the leading technology supplier of robots and production machines.

Our team is always available to answer any questions on this product and other solutions. Ask us questions and challenge us. We will find a solution!

Best regards,

Your SCHUNK team

Customer Management

Tel. +49-7133-103-2503

Fax +49-7133-103-2189

cmg@de.schunk.com



Please read the operating manual in full and keep it close to the product.

Table of Contents

1	General	5
1.1	About this manual.....	5
1.1.1	Presentation of Warning Labels	5
1.1.2	Definition of Terms	6
1.1.3	Applicable documents	6
1.2	Warranty	6
1.3	Scope of delivery.....	6
1.4	Accessories	6
2	Basic safety notes	7
2.1	Intended use.....	7
2.2	Not intended use	7
2.3	Constructional changes.....	7
2.4	Spare parts	7
2.5	Ambient conditions and operating conditions	8
2.6	Personnel qualification	8
2.7	Personal protective equipment	8
2.8	Transport.....	9
2.9	Malfunctions	9
2.10	Disposal	9
2.11	Fundamental dangers	10
2.11.1	Protection during handling and assembly	10
2.11.2	Protection during commissioning and operation	10
2.11.3	Protection against dangerous movements	10
2.12	Notes on particular risks	12
3	Technical data	13
3.1	Basic data	13
3.2	Compliance force	14
4	Design and description	15
4.1	Design	15
4.2	Description	15
5	Assembly and settings	16
5.1	Assembling and connecting.....	16
5.2	Connections	17
5.2.1	Mechanical connection.....	17
5.2.2	Pneumatic connection.....	18
5.3	Setting axis fixation.....	20
6	Operation.....	21

7 Troubleshooting	22
7.1 Tool wears out or breaks	22
7.2 Tool rattles when deburring	22
7.3 Uneven deburring result	22
7.4 Residue on the workpiece after deburring	22
7.5 Tool blocked during machining operation.....	23
8 Maintenance	24
8.1 Notes.....	24
8.2 Maintenance interval	24
8.3 Lubrication of the motor	24
8.4 Changing the file	25
8.5 Changing the spindle boot	26
8.6 Changing the ring cylinder assembly	26
8.7 Assembly drawings	27
9 Translation of the original declaration of incorporation	28
10 UKCA declaration of incorporation	29
11 Information on the RoHS Directive, REACH Regulation and Substances of Very High Concern (SVHC)	30

1 General

1.1 About this manual

This manual contains important information for a safe and appropriate use of the product.

This manual is an integral part of the product and must be kept accessible for the personnel at all times.

Before starting work, the personnel must have read and understood this operating manual. Prerequisite for safe working is the observance of all safety instructions in this manual.

In addition to these instructions, the documents listed under ▶ 1.1.3 [6] are applicable.

NOTE: The illustrations in this manual are intended to provide a basic understanding and may deviate from the actual version.

1.1.1 Presentation of Warning Labels

To make risks clear, the following signal words and symbols are used for safety notes.



⚠ DANGER

Dangers for persons!

Non-observance will inevitably cause irreversible injury or death.



⚠ WARNING

Dangers for persons!

Non-observance can lead to irreversible injury and even death.



⚠ CAUTION

Dangers for persons!

Non-observance can cause minor injuries.

NOTICE

Material damage!

Information about avoiding material damage.

1.1.2 Definition of Terms

The term "product" replaces the product name on the title page in this manual.

1.1.3 Applicable documents

- General terms of business *
- Catalog data sheet of the purchased product *
- Assembly and operating manuals of the accessories *

The documents labeled with an asterisk (*) can be downloaded from schunk.com/downloads.

1.2 Warranty

If the product is used as intended, the warranty is valid for 24 months from the ex-works delivery date under the following conditions:

- Observe the ambient conditions and operating conditions

Parts touching the workpiece and wear parts are not included in the warranty.

1.3 Scope of delivery

The scope of delivery includes

- Compliant Reciprocating Tool CRT in the version ordered
- Safety information (product-specific instructions available online)
- File set
- Hexagon socket wrench (3 mm)

1.4 Accessories

The following accessories are available for the product, which must be ordered separately:

- Adapter plate
- File holder

For information regarding which accessory articles can be used with the corresponding product variants, see catalog data sheet.

2 Basic safety notes

2.1 Intended use

The product is intended exclusively for machining workpieces with a robot.

- The product may only be used within the scope of its technical data, ▶ 3 [13].
- The product is intended for installation in a machine/ automated system or for attachment to a robot. The applicable guidelines for the machine/automated system must be observed and complied with.
- The product is intended for industrial and industry-oriented use. Its use outside enclosed spaces is only permitted if suitable protective measures are taken against outdoor exposure. The product is not suitable for use in salty air.
- Appropriate use of the product includes compliance with all instructions in this manual.
- Any utilization that exceeds or differs from the appropriate use is regarded as misuse.

2.2 Not intended use

It is not intended use if the product is used, for example, as a pressing tool, stamping tool, lifting gear, guide for tools, cutting tool, clamping device or a drilling tool.

- Inappropriate use includes using the product as a hand tool.
- Any utilization that exceeds or differs from the appropriate use is regarded as misuse.

2.3 Constructional changes

Implementation of structural changes

Modifications, changes or reworking, e.g. additional threads, holes, or safety devices, can damage the product or impair its functionality or safety.

- Structural changes should only be made with the written approval of SCHUNK.

2.4 Spare parts

Use of unauthorized spare parts

Using unauthorized spare parts can endanger personnel and damage the product or cause it to malfunction.

- Use only original spare parts or spares authorized by SCHUNK.

2.5 Ambient conditions and operating conditions

Required ambient conditions and operating conditions

Incorrect ambient and operating conditions can make the product unsafe, leading to the risk of serious injuries, considerable material damage and/or a significant reduction to the product's life span.

- Make sure that the product is used only in the context of its defined application parameters, ▶ 3 [13].

2.6 Personnel qualification

Inadequate qualifications of the personnel

If the personnel working with the product is not sufficiently qualified, the result may be serious injuries and significant property damage.

- All work may only be performed by qualified personnel.
- Before working with the product, the personnel must have read and understood the complete assembly and operating manual.
- Observe the national safety regulations and rules and general safety instructions.

The following personal qualifications are necessary for the various activities related to the product:

Trained electrician

Due to their technical training, knowledge and experience, trained electricians are able to work on electrical systems, recognize and avoid possible dangers and know the relevant standards and regulations.

Qualified personnel

Due to its technical training, knowledge and experience, qualified personnel is able to perform the delegated tasks, recognize and avoid possible dangers and knows the relevant standards and regulations.

Instructed person

Instructed persons were instructed by the operator about the delegated tasks and possible dangers due to improper behaviour.

Service personnel of the manufacturer

Due to its technical training, knowledge and experience, service personnel of the manufacturer is able to perform the delegated tasks and to recognize and avoid possible dangers.

2.7 Personal protective equipment

Use of personal protective equipment

Personal protective equipment serves to protect staff against danger which may interfere with their health or safety at work.

- When working on and with the product, observe the occupational health and safety regulations and wear the required personal protective equipment.
- Observe the valid safety and accident prevention regulations.
- Wear protective gloves to guard against sharp edges and corners or rough surfaces.
- Wear heat-resistant protective gloves when handling hot surfaces.
- Wear protective gloves and safety goggles when handling hazardous substances.
- Wear close-fitting protective clothing and also wear long hair in a hairnet when dealing with moving components.
- Wear ear protection and safety goggles during the machining process.

2.8 Transport

Handling during transport

Incorrect handling during transport can make the product unsafe and risk the danger of serious injuries and considerable material damage.

- During transport and handling, secure the product to prevent it from falling.
- Do not walk under suspended loads.

2.9 Malfunctions

Behavior in case of malfunctions

- Immediately remove the product from operation and report the malfunction to the responsible departments/persons.
- Order appropriately trained personnel to rectify the malfunction.
- Do not recommission the product until the malfunction has been rectified.
- Test the product after a malfunction to establish whether it still functions properly and no increased risks have arisen.

2.10 Disposal

Handling of disposal

The incorrect handling of disposal may impair the product's safety and cause serious injuries as well as considerable material and environmental harm.

- Follow local regulations on dispatching product components for recycling or proper disposal.

2.11 Fundamental dangers

General

- Observe safety distances.
- Never deactivate safety installations.
- Install the provided protective product in the danger zone before switching on the product.
- Remove the energy supplies before installation, modification, maintenance, or adjustment work. Ensure there is no residual energy in the system.
- Do not move parts by hand while the energy supply is connected.
- Do not reach into the movement area of the product during operation.

2.11.1 Protection during handling and assembly

Incorrect handling and assembly

Incorrect handling and assembly may impair the product's safety and cause serious injuries and considerable material damage.

- Have all work carried out by appropriately qualified personnel.
- For all work, secure the product against accidental operation.
- Observe the relevant accident prevention rules.
- Use suitable assembly and transport equipment and take precautions to prevent jamming and crushing.

Incorrect lifting of loads

Falling loads may cause serious injuries and even death.

- Stand clear of suspended loads and do not step into their swiveling range.
- Never move loads without supervision.
- Do not leave suspended loads unattended.

2.11.2 Protection during commissioning and operation

Falling or violently ejected components

Falling and violently ejected components can cause serious injuries and even death.

- Take appropriate protective measures to secure the danger zone.
- Never step into the danger zone during operation.

2.11.3 Protection against dangerous movements

Unexpected movements

Residual energy in the system may cause serious injuries while working with the product.

- Switch off the energy supply, ensure that no residual energy remains and secure against inadvertent reactivation.
- Never rely solely on the response of the monitoring function to avert danger. Until the installed monitors become effective, it must be assumed that the drive movement is faulty, with its action being dependent on the control unit and the current operating condition of the drive. Perform maintenance work, modifications, and attachments outside the danger zone defined by the movement range.
- To avoid accidents and/or material damage, human access to the movement range of the machine must be restricted. Limit/prevent accidental access for people in this area due through technical safety measures. The protective cover and protective fence must be rigid enough to withstand the maximum possible movement energy. EMERGENCY STOP switches must be easily and quickly accessible. Before starting up the machine or automated system, check that the EMERGENCY STOP system is working. Prevent operation of the machine if this protective equipment does not function correctly.

2.12 Notes on particular risks



⚠ DANGER

Risk of fatal injury from suspended loads!

Falling loads can cause serious injuries and even death.

- Stand clear of suspended loads and do not step within their swiveling range.
- Never move loads without supervision.
- Do not leave suspended loads unattended.
- Wear suitable protective equipment.



⚠ WARNING

Risk of injury from objects falling and being ejected!

Falling and ejected objects during operation can lead to serious injury or death.

- Take appropriate protective measures to secure the danger zone.



⚠ WARNING

Risk of injury due to unexpected movements!

If the power supply is switched on or residual energy remains in the system, components can move unexpectedly and cause serious injuries.

- Before starting any work on the product: Switch off the power supply and secure against restarting.
- Make sure, that no residual energy remains in the system.



⚠ CAUTION

Risk of injury from flying chips and dirt particles

During operation, flying chips and dirt particles can cause eye injuries.

- Always wear appropriate personal protective equipment, particularly protective goggles.
- Take suitable protective measures to secure the danger zone.

3 Technical data

3.1 Basic data

Designation	CRT
Weight [kg]	3.08
Compensation angle radial X/Y [°]	±1.8
Compensation path X/Y at the collet chuck [mm]	
Recommended	±4
Max.	±8
Compliance force [N] (radial)	
Min.	18
Max.	62
File stroke [mm]	5
Nominal operating pressure [bar]	
Compensation air connection	1-4.1
Motor air connection	6.2
Pressure medium	Compressed air (clean, dry, filtered (≤ 30 µm), oiled)
Max. air consumption [l/s]	2.8
Oil consumption [drops/min]	1-2
Motor operating data	
Motor	Compressed air drive
Idle speed [RPM]	12,000
Ambient conditions and operating conditions	
Designation	CRT
Ambient temperature [°C]	
Min.	+5
Max.	+35

3.2 Compliance force

NOTE

The compliance force may vary from product to product and should be treated as a guide value only. The actual force characteristics depend on the installation position and the condition of the product. The compliance pressure should be selected depending on the material of the workpiece, the type of tool and the amount of material to be removed.

NOTE

The specified compliance force does not correspond to the actual values when the product is mounted horizontally.

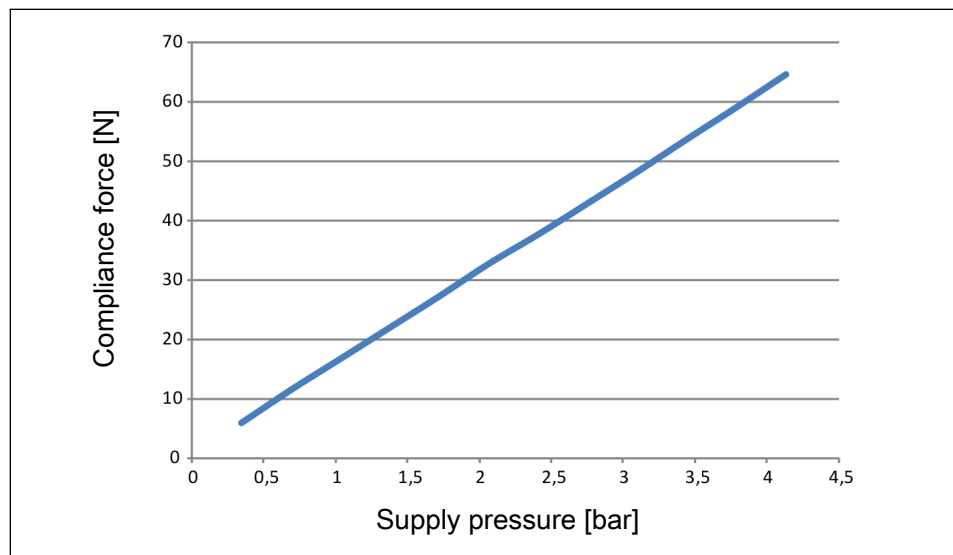

Compliance force as a function of operating pressure

4 Design and description

4.1 Design

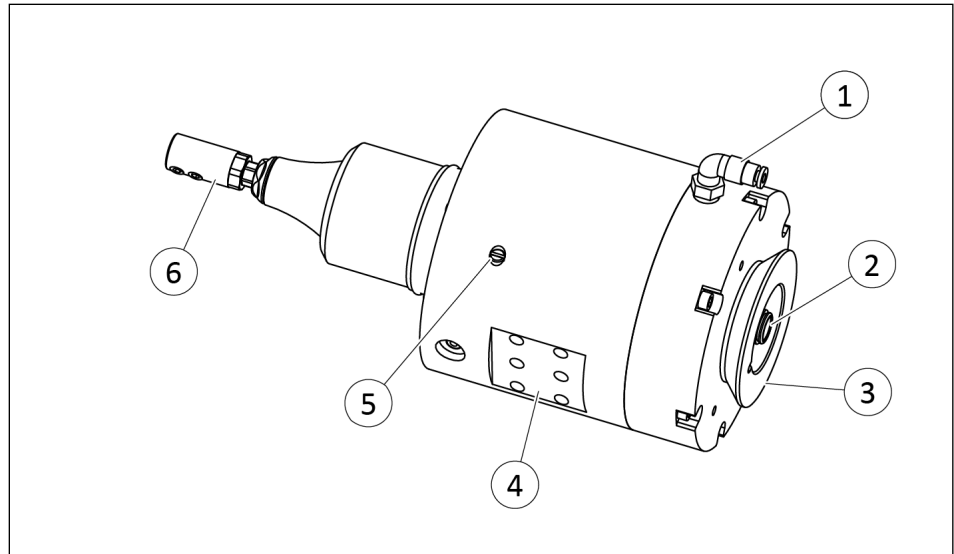

- | | |
|---|--------------------------------|
| 1 | Compensation air connection |
| 2 | Motor air connection |
| 3 | Robot side connection (axial) |
| 4 | Robot side connection (radial) |
| 5 | Axis fixation set screw |
| 6 | File holder |

4.2 Description

Pneumatically driven file with radial compensation for deburring workpieces

5 Assembly and settings

5.1 Assembling and connecting



⚠ WARNING

Risk of injury due to unexpected movements!

If the power supply is switched on or residual energy remains in the system, components can move unexpectedly and cause serious injuries.

- Before starting any work on the product: Switch off the power supply and secure against restarting.
- Make sure, that no residual energy remains in the system.

1. Check the evenness of the mounting surface, ▶ 5.2.1 [17].
2. Connect compressed air supply, ▶ 5.2.2 [18].
3. Attach the product to the robot, ▶ 5.2.1 [17].
 - ⇒ If necessary, use appropriate connection elements (adapter plates).
 - ⇒ Observe the permissible depth of engagement.
4. If necessary, adjust the axis fixation set screw, ▶ 5.3 [20].

5.2 Connections

5.2.1 Mechanical connection

Check the flatness of the bolting surface

The values refer to the mounting surface to which the attachments provided are mounted (e.g. grippers, rotary modules).

Edge lengths	Permissible unevenness
< 100	< 0.02
> 100	< 0.05

Tab.: Requirements for the flatness of the bolting surface (dimensions in mm)

The product can be assembled from two sides.

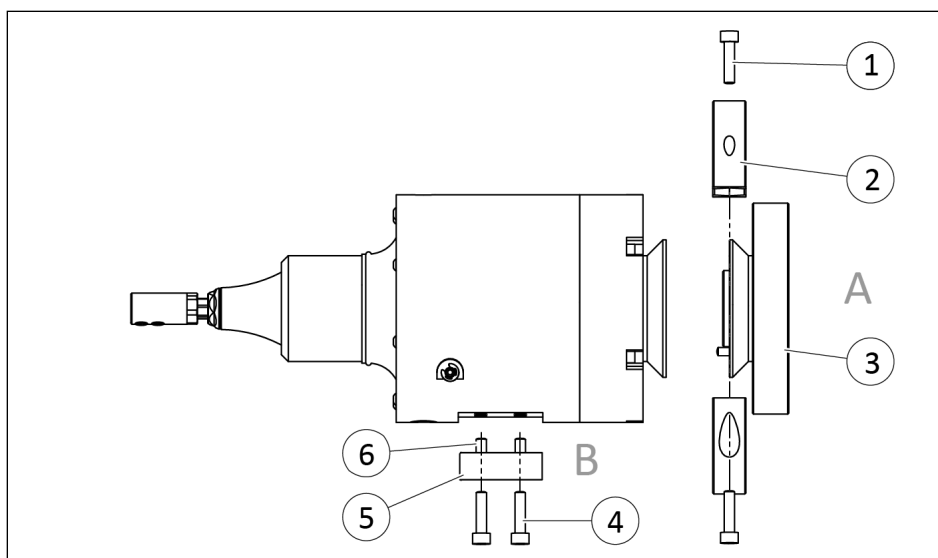

Item	Mounting	CRT
Side A		
1	Mounting screw *	-
2	Clamping collar *	-
3	Adapter plate *	-
Side B		
4	Mounting screw *	M6
	Max. depth of engagement from locating surface [mm]	9
5	Adapter plate radial *	-
6	Fitting bore for centering pin [mm]	6 ^{H6}
	Max. depth of engagement from locating surface [mm]	5.5

* Mounting material is not included in the scope of delivery. (available from SCHUNK on request)

5.2.2 Pneumatic connection

NOTICE

Damage to the air hoses possible!

The hoses connected to the air connection spindle can be damaged if the mounting is too tight.

- Allow hoses to hang flexibly so as not to impair the compensating movements of the motor.

NOTE

- Observe the requirements for the compressed air supply, Link ##.
- **For compensation air connection:** For better regulation of the compressed air, use a self-relieving regulator with air bleed.
- **For air connection spindle:** For better regulation of the compressed air, use a 2-way valve and a pressure regulator set at max. 6.2 bar.

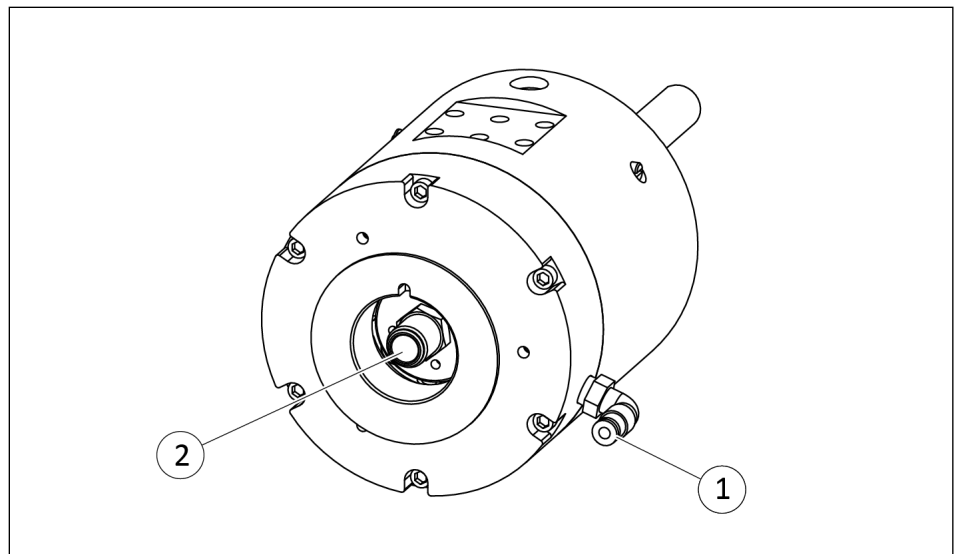

1 Compensation air connection

2 Motor air connection

Item	Mounting	CRT
1	Compensation air connection [mm]	4
2	Motor air connection [mm]	10

Pneumatics wiring diagram

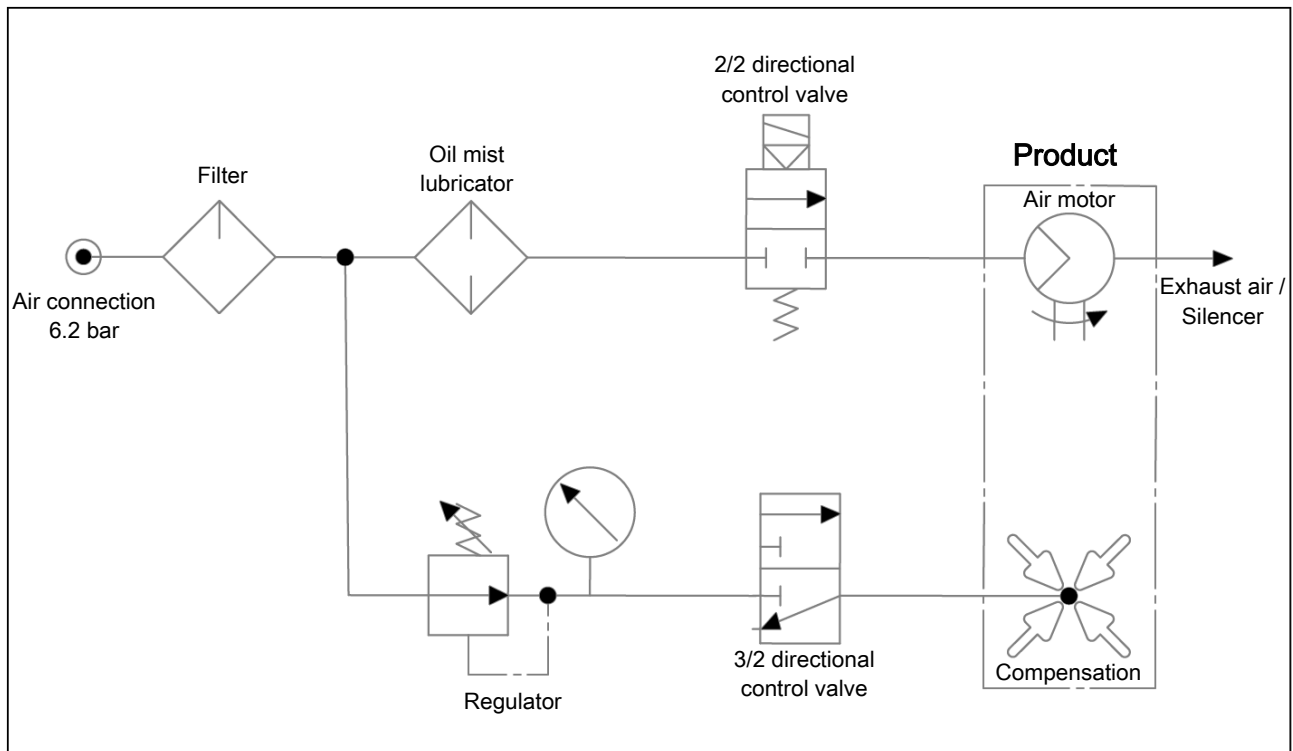

Pneumatic wiring diagram

5.3 Setting axis fixation

NOTICE

Risk of damage to the product!

A load along the Y-axis when using axis fixation will damage the compensation mechanism.

- When using a single-axis lock, only apply loads in the X direction.
- The product must always be vertical in relation to the edge of the workpiece. Orient the robot appropriately depending on the geometry of the workpiece.

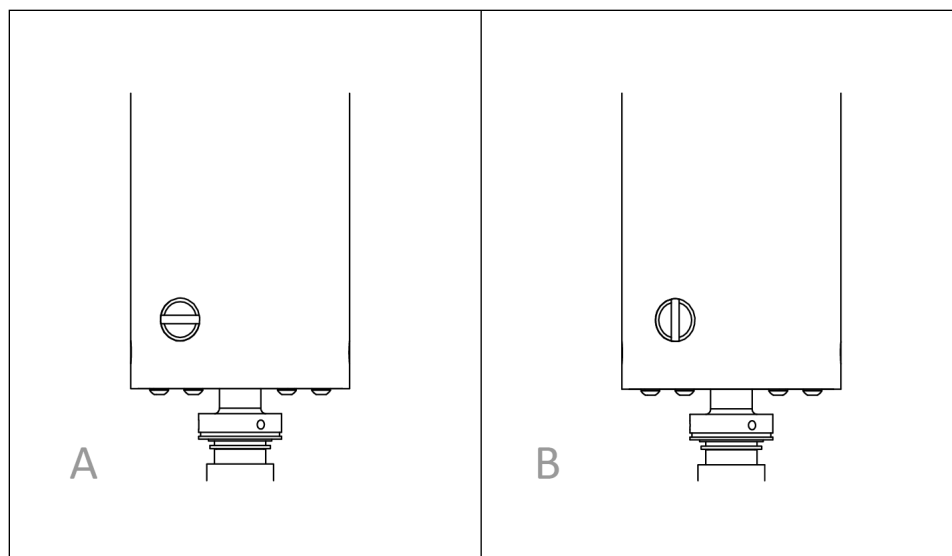

A = Locked; B = Unlocked

1. Adjust the screw to the desired position:
 - ⇒ Unlocked = 360° compensation
 - ⇒ Locked = Compensation only in X-axis
2. Manually check ease of movement and possible directions of movement for correct function.

6 Operation

NOTICE

Damage to the spindle by coolant!

When using with coolant, ensure that no coolant drips onto the spindle. Dry machining is recommended.

NOTICE

Possible damage to the tool and the tool bearing!

If the tool quickly approaches the workpiece vertically, this will lead to an uneven machining result and premature wear of the bearing and tool.

- Adjust the process parameters precisely.
-
- Product was completely assembled.
 - 1. Adjust the robot control system so that the product approaches the workpiece slowly and at a shallow angle.
 - 2. Adjust feed rate.
 - 3. Ensure that the distance to the workpiece is correctly adjusted before each new machining operation.
 - 4. Plan the robot path so that 50% of the compensation function of the product is used at the theoretical tool edge. This allows the product to use its flexibility to machine areas evenly despite different initial geometries without losing contact with the workpiece. If this is not possible, several machining passes may be necessary.
 - 5. When using the axis fixation, always set the free compensation axis of the product perpendicular to the edge of the workpiece.

7 Troubleshooting

7.1 Tool wears out or breaks

Possible cause	Corrective action
Tool is not suitable for the workpiece.	Select the tool that matches the properties of the workpiece. Coat tool if necessary.
Too much material is being removed.	Check process parameters, reduce infeed, reduce air pressure for compensation, perform machining in several passes., ▶ 6 [21].
The load on the tool is too great because the product is moving too slowly.	Increase feed rate.
Compensation mechanism at the stop.	Readjust the offset, ▶ 6 [21].
High force on initial contact with workpiece.	Change the feed rate and/or angle when approaching the workpiece.

7.2 Tool rattles when deburring

Possible cause	Corrective action
Feed rate not set correctly.	Check process parameters, reduce infeed, reduce air pressure for compensation, perform machining in several passes., ▶ 6 [21].
Compliance pressure too low.	
Too much material is being removed.	
Tool is not suitable for the workpiece.	Select the tool that matches the properties of the workpiece.
Tool is worn out.	Change tool

7.3 Uneven deburring result

Possible cause	Corrective action
The pressure valve is defective.	Change pressure valve.
Ring cylinder assembly is damaged.	Check ring cylinder assembly for wear and replace if necessary, ▶ 8.6 [26]

7.4 Residue on the workpiece after deburring

Possible cause	Corrective action
Feed rate not set correctly.	Readjust feed rate.

Possible cause	Corrective action
Tool is worn out.	Change tool
Tool is not suitable for the workpiece.	Select the tool that matches the properties of the workpiece.
Too much material is being removed.	Check process parameters, reduce infeed, reduce air pressure for compensation, perform machining in several passes., ▶ 6 [21].
Workpiece is approached too fast or at an incorrect angle.	Check process parameters, reduce infeed, reduce air pressure for compensation, perform machining in several passes., ▶ 6 [21].
Tool clogging with material.	Use another tool, e.g. with fewer teeth.

7.5 Tool blocked during machining operation

Possible cause	Corrective action
Insufficient or no compressed air supply.	Check compressed air lines. Check that the pressure valve is set to 6.2 bar. Pressure must be maintained while the spindle is running.
Tool not mounted correctly.	Secure tool in file holder.
Workpiece is approached too fast or at an incorrect angle.	Check process parameters, reduce infeed, reduce air pressure for compensation, perform machining in several passes., ▶ 6 [21].

8 Maintenance

NOTICE

Material damage due to incorrect assembly and disassembly!

Incorrect disassembly and reassembly may cause damage to the product and/or accessories.

- SCHUNK recommends having the product and/or accessories checked and repaired by SCHUNK if necessary.

8.1 Notes



⚠ WARNING

Risk of injury from electric shock due to contact with live parts!

- Before starting any work: Disconnect the power supply from the mains and secure against accidental switch-on.
- Work may only be performed by appropriately qualified personnel.

Original spare parts

Use only original spare parts of SCHUNK when replacing spare and wear parts.

8.2 Maintenance interval

Maintenance interval	Maintenance work
daily	Check files for damage and wear, replace if necessary, ▶ 8.4 [25].
weekly	Check spindle boot for damage and wear, replace if necessary, ▶ 8.5 [26].
as required	Change ring cylinder assembly, ▶ 8.6 [26]. Send damaged products to SCHUNK for repair.

8.3 Lubrication of the motor

To maximize service life, only operate the motor for the product with lubrication in the air supply. To do this, lubricate the air supply to the motor with 1–2 drops of a standard pneumatic tool oil per minute.

8.4 Changing the file



⚠ WARNING

Risk of burns through contact with hot surfaces!

Surfaces of components can heat up severely during operation. Skin contact with hot surfaces causes severe burns to the skin.

- For all work in the vicinity of hot surfaces, wear safety gloves.
- Before carrying out any work, make sure that all surfaces have cooled down to the ambient temperature.

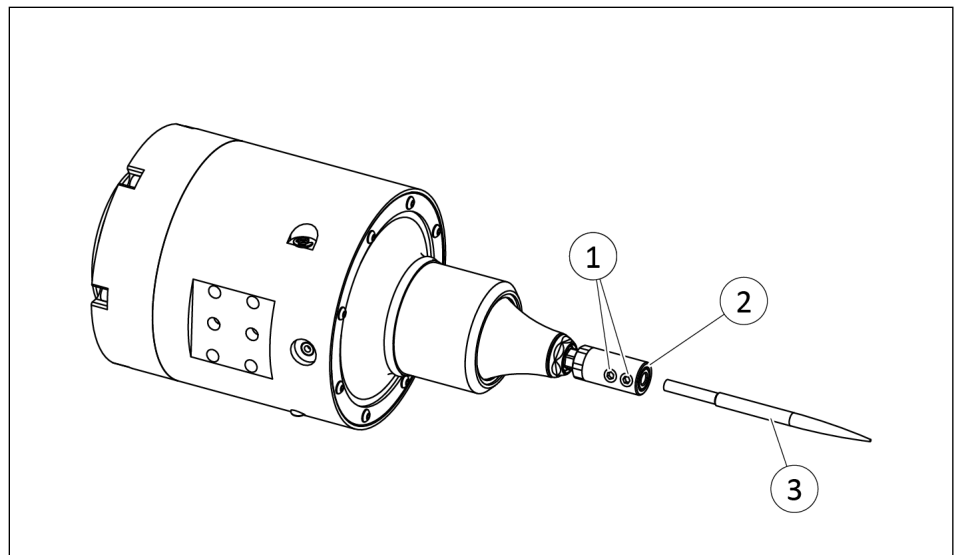

1. Remove the compressed air hose.
2. Detach the mounting screws (1) using the hexagon socket wrench included in the scope of delivery.
3. Remove file (3) from the file holder (2).
4. Insert the new file (3) into the file holder (2) and fasten it with screws (1).
5. Connect all compressed air lines.

8.5 Changing the spindle boot

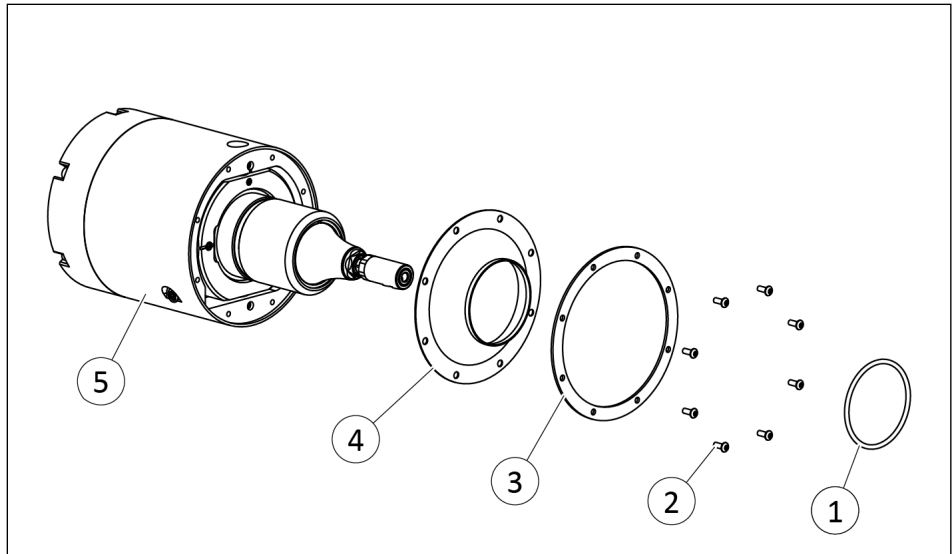

1. Remove the compressed air hose.
2. Remove the O-ring (1).
3. Loosen the mounting screws (2) and remove the boot ring (3) from the main housing (5).
4. Remove the spindle boot (4).
5. Apply Loctite 222 threadlocker to the mounting screws (2).
6. Install the new spindle boot (4) and boot ring (3) on the main housing (5) using mounting screws (2).
⇒ Carefully tighten the screws hand-tight.
7. Tighten O-ring (1) over the spindle boot (4).
8. Connect all compressed air lines.

8.6 Changing the ring cylinder assembly

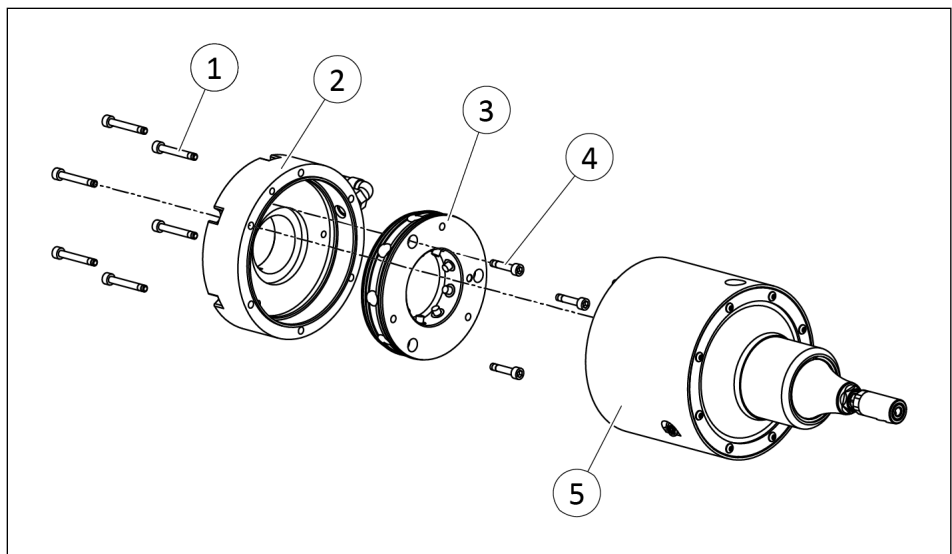

1. Remove the compressed air hose.
2. Remove product from the system/machine.

3. Detach the mounting screws (1) and remove the main housing (2) from the rear housing assembly (5).
4. Detach the mounting screws (4) and disassemble the ring cylinder assembly (3).
5. Lubricate the O-rings in the new ring cylinder assembly and the bore holes in the main housing.
6. Align the new ring cylinder assembly (3) with the centering bore hole in the main housing (5) and slide it carefully into the main housing.
7. Fasten the ring cylinder assembly (3) in the main housing (1) with mounting screws (4).
 - ⇒ Max. tightening torque: 1.36 Nm
8. Place the main housing (2) on the rear housing assembly (5) and fasten with mounting screws (1).
 - ⇒ Max. tightening torque: 2.83 Nm
9. Connect all compressed air lines.
10. Mount product onto the system/machine.

8.7 Assembly drawings

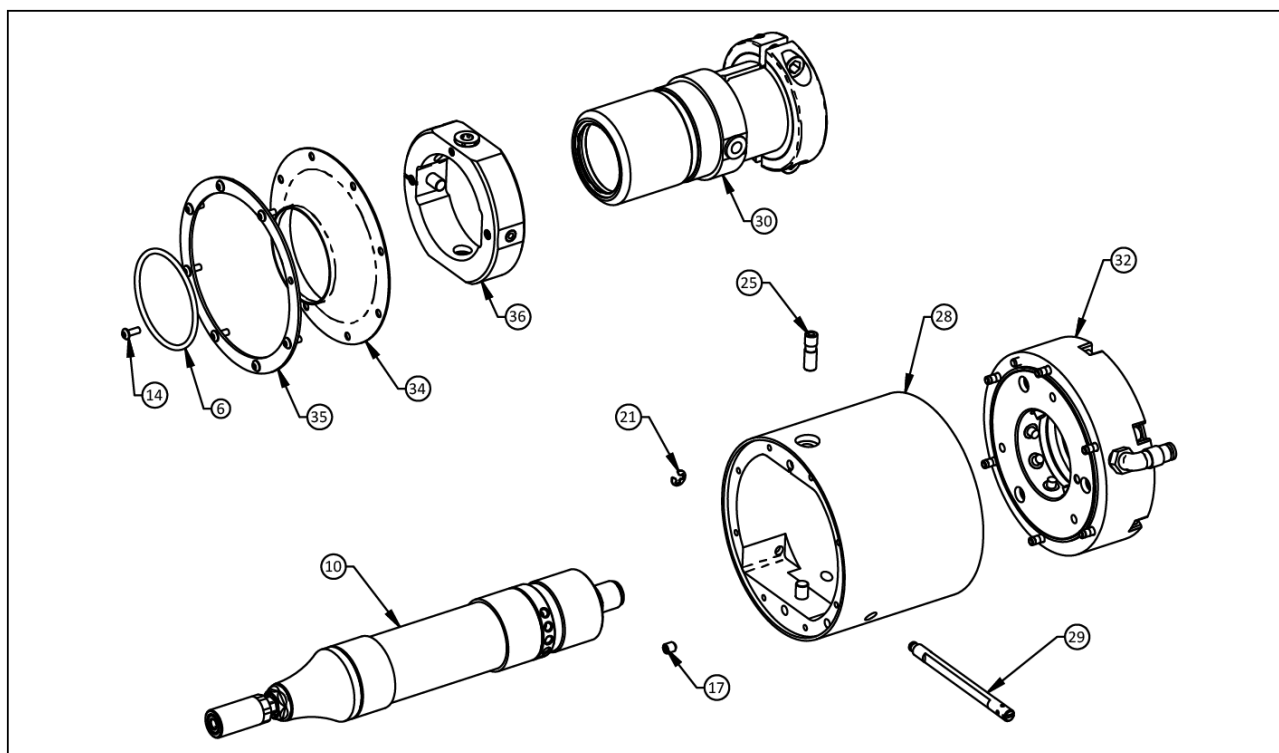

9 Translation of the original declaration of incorporation

in terms of the Directive 2006/42/EG, Annex II, Part 1 Section B.

Manufacturer/
Distributor SCHUNK SE & Co. KG
Spanntechnik | Greiftechnik | Automatisierungstechnik
Bahnhofstr. 106 – 134
D-74348 Lauffen/Neckar

We hereby declare that the partly completed machine described below

Product designation: Compliant Reciprocating Tool / CRT /pneumatic
ID number 1427058

meets the following basic occupational health and safety of the Machinery Directive 2006/42/EC:

No. 1.1.1, No. 1.1.2, No. 1.1.3, No. 1.1.5, No. 1.3.2, No. 1.5.3, No. 1.5.4, No. 1.5.6, No. 1.5.8, No. 1.5.10, No. 1.5.11, No. 1.5.13

The partly completed machinery may not be put into operation until it has been confirmed that the machine into which the partly completed machinery is to be installed complies with the provisions of the Machinery Directive (2006/42/EC). The declaration shall be rendered invalid if modifications are made to the product.

Applied harmonized standards, especially:

EN ISO 12100:2010 Safety of machinery – General principles for design –
Risk assessment and risk reduction

The special technical documentation according to Annex VII, Part B, belonging to the partly completed machine, has been created.

Person authorized to compile the technical documentation:
Stefanie Walter, Address: see manufacturer's address

Signature: see original declaration

Lauffen/Neckar, February 2025

Dr.-Ing. Manuel Baumeister,
Head of Systems Engineering,
Technology & Innovation

10 UKCA declaration of incorporation

in accordance with the Supply of Machinery (Safety) Regulations 2008.

Manufacturer/ Distributor	SCHUNK Intec Limited Clamping and gripping technology 3 Drakes Mews, Crownhill MK8 0ER Milton Keynes
------------------------------	---

We hereby declare that on the date of the declaration the following partly completed machine complied with all basic safety and health regulations found in the "Supply of Machinery (Safety) Regulations 2008".

The declaration shall be rendered invalid if modifications are made to the product.

Product designation:	Compliant Reciprocating Tool / CRT / pneumatic
ID number	1427058

The partly completed machine may not be put into operation until it has been confirmed that the machine into which the partly completed machine is to be installed complies with the provisions of the "Supply of Machinery (Safety) Regulations 2008".

Applied harmonized standards, especially:

EN ISO 12100:2010	Safety of machinery – General principles for design – Risk assessment and risk reduction
-------------------	--

The special technical documentation according to Annex VII, Part B, belonging to the partly completed machine, has been created.

Person authorized to compile the technical documentation:
Marcel Machado, address: refer to manufacturer's address



Lauffen/Neckar, February 2025

Dr.-Ing. Manuel Baumeister,
Head of Systems Engineering,
Technology & Innovation

11 Information on the RoHS Directive, REACH Regulation and Substances of Very High Concern (SVHC)

RoHS Directive

SCHUNK products are classified as "large-scale stationary installations" or as "large-scale stationary industrial tools" within the meaning of Directive 2011/65/EU and its extension 2015/863/EU "on the restriction of the use of certain hazardous substances in electrical and electronic equipment (RoHS)", or fulfill their intended function only as part of one. Therefore products from SCHUNK do not fall within the scope of the directive at this time.

REACH Regulation

Products from SCHUNK fully comply with the regulations of Regulation (EC) No. 1907/2006 "concerning the Registration, Evaluation, Authorization and Restriction of Chemicals (REACH)" and its amendment 2022/477. SCHUNK attaches great importance to completely avoiding chemicals of concern to humans and the environment wherever possible.

Only in rare exceptional cases do SCHUNK products contain SVHC substances on the candidate list with a mass content above 0.1%. In accordance with Article. 33 (1) of Regulation (EC) No. 1907/2006, SCHUNK complies with its duty to "communicate information on substances in articles" and lists the components concerned and the substances used in an overview that can be viewed at [schunk.com\SVHC](https://www.schunk.com/SVHC).

Signature: see original declaration

Lauffen/Neckar, February 2025

Dr.-Ing. Manuel Baumeister,
Head of Systems Engineering,
Technology & Innovation





SCHUNK SE & Co. KG
Spanntechnik | Greiftechnik | Automatisierungstechnik

Bahnhofstr. 106 - 134
D-74348 Lauffen/Neckar
Tel. +49-7133-103-0
info@de.schunk.com
schunk.com

Folgen Sie uns | *Follow us*



Wir drucken nachhaltig | *We print sustainable*