



# TANDEM KSP plus

Clamping Force Blocks I pneumatic

Superior Clamping and Gripping



# Product Overview



## Gripping Systems

## Clamping Technology



Chuck Jaws



Lathe Chucks



Stationary Workholding



Toolholders



Hydraulic Expansion Technology



VERO-S



TANDEM



ROTA



KONTEC



Tombstones



MAGNOS

# Challenges

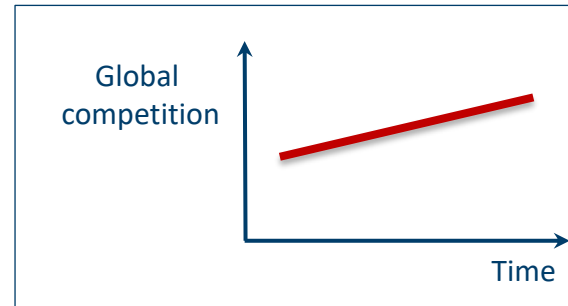
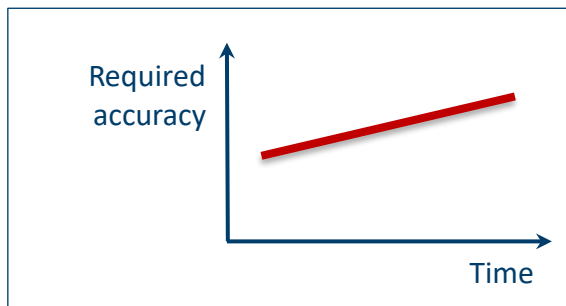
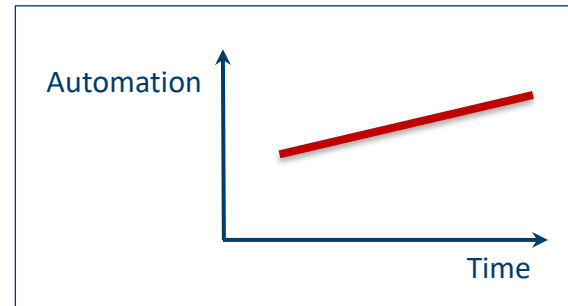
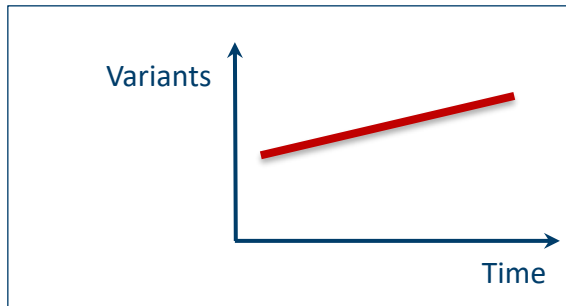

**Increasing relevance of the set-up process**

# TANDEM Clamping Force Blocks

**High workpiece density at small space**

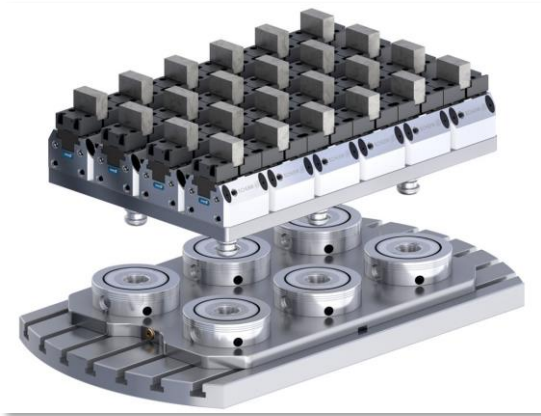



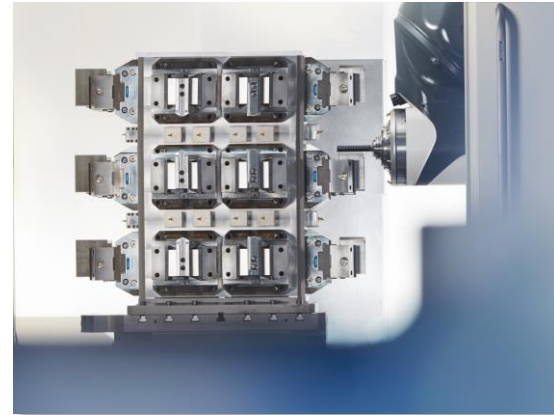



**Optimum accessibility of the machine spindle to the workpiece**

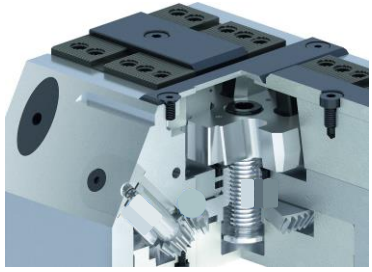

**High duration at low non-productive times per workpiece**

# TANDEM Overview

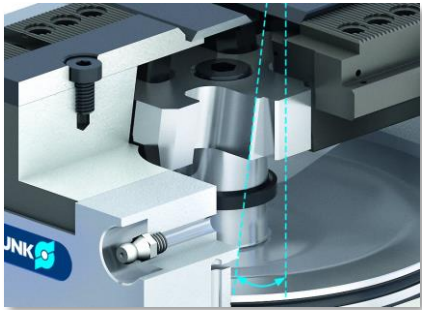

	Pneumatic (KSP plus)	Hydraulic (KSH plus)	Manually (KSA plus)	Spring-loaded (KSF plus)
Actuation Types				

	Standard stroke	Long stroke (-LH)	With fixed jaw (-F)
Variants			

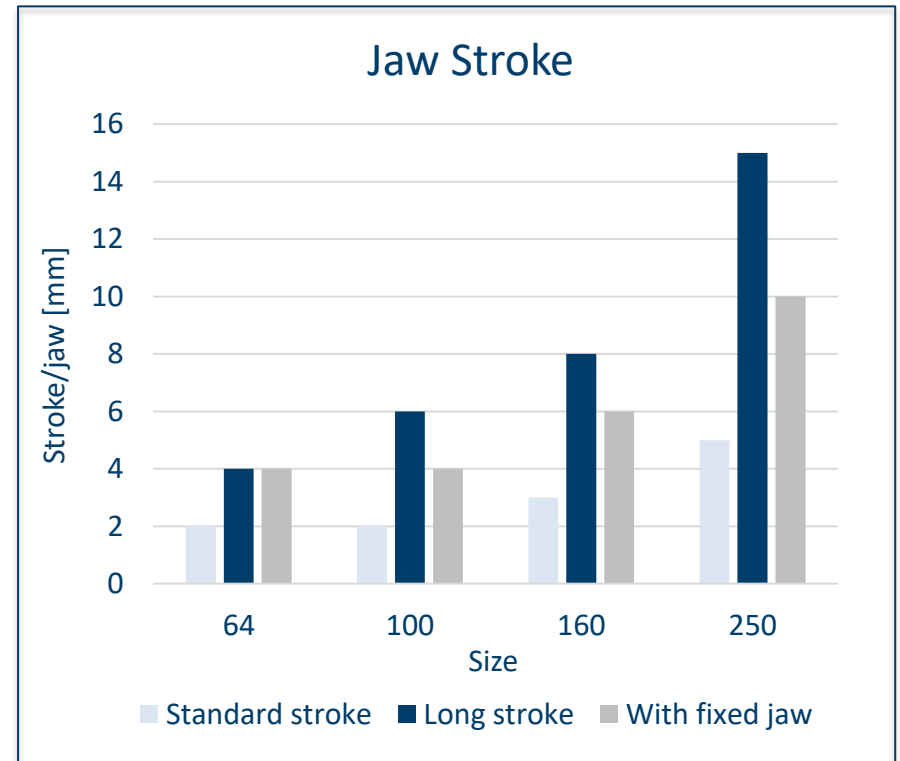
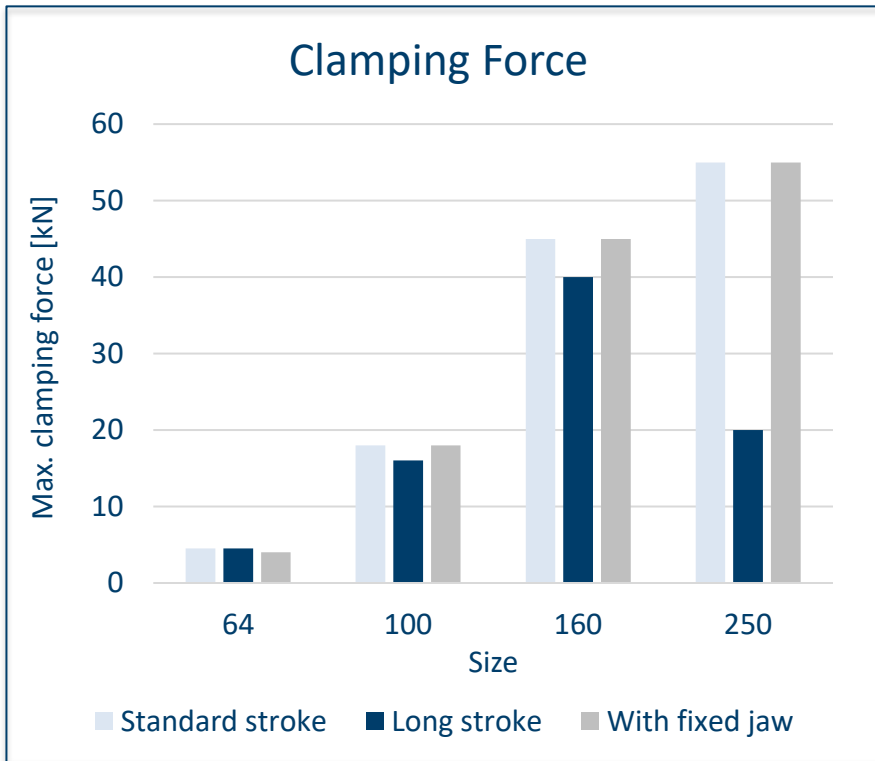
# TANDEM Portfolio



# TANDEM Jaw Program

Top Jaws Blank		
Mounting: via tongue and groove	Mounting: via fine serrations 1,5 x 60°	
KTR / KTR-H	STR / STR-H	STR-S
		

Supporting Jaws + SCHUNK Jaw Program	
TBA-D	Chuck Jaws
	  

# SCHUNK Services

## Engineering

- Dimensioning of special plates designed to the manufacturing specifications
- Development of special solutions together with the customer
- FEM analysis for critical components

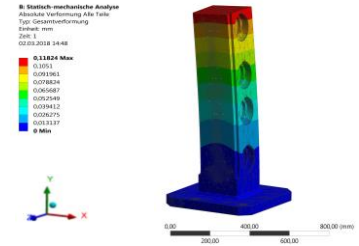

## Testing

- Endurance tests with all new developments
- Abrasion checking
- Measurement of accuracy



## Service

- Initial operation of customer's solution
- Inspection and maintenance
- Repairs



# TANDEM Overview

Pneumatic



Hydraulic



Manual



Spring force



# TANDEM KSP plus

## Application Example



# TANDEM KSP plus



- ① Wedge hook drive
- ② Hardened and extremely rigid base body
- ③ Optimized lubrication system
- ④ Long jaw guidance
- ⑤ Low height
- ⑥ Improved design which is insensitive to dirt
- ⑦ Standard chuck jaw interface
- ⑧ Optimized outside contour
- ⑨ Control of the clamping modules
- ⑩ Chuck pistons guided in the body
- ⑪ Lubrication channels in the cover plate
- ⑫ Fitting screws available as an option

# TANDEM KSP plus

## Force Flow in the KSP plus

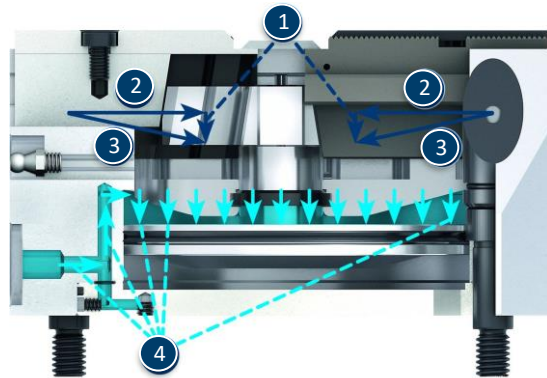

- 1 Actuating force depending on the pneumatic pressure and piston area
- 2 Clamping force depending on the actuating force and the transmission ratio
- 3 Normal force between the base jaw and chuck body
- 4 Pneumatic pressure

## Clamping Force dependent on the Actuation Pressure

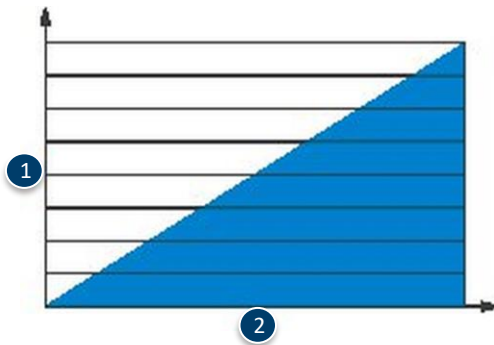

- 1 Clamping force
- 2 Actuation force

## Z-version (optional)

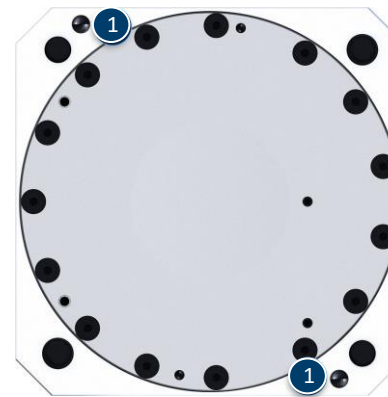

- 1 Positioning bore

# TANDEM KSP plus

Chip-repellent design



Cover plugs for the mounting screws

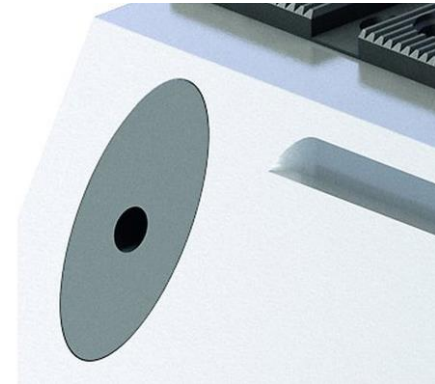

Alignment edge



Lubrication system

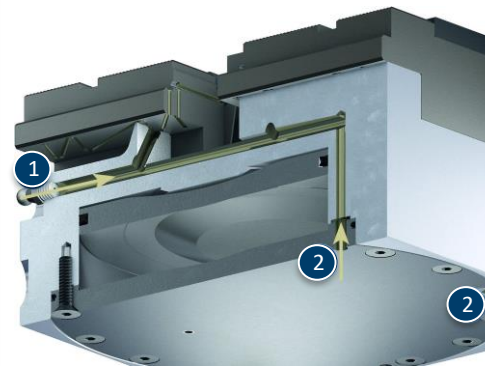

1 Manual lubrication

2 Central lubrication

# TANDEM KSP plus

## Coolant drain hole



## Version IN – know whether opened or clamped

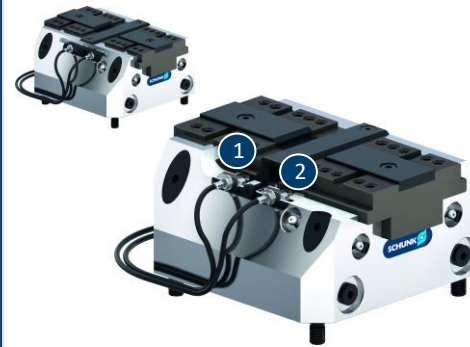

- 1 Inductive proximity switch for monitoring „clamped“
- 2 Inductive proximity switch for monitoring „opened“

## BWM variant

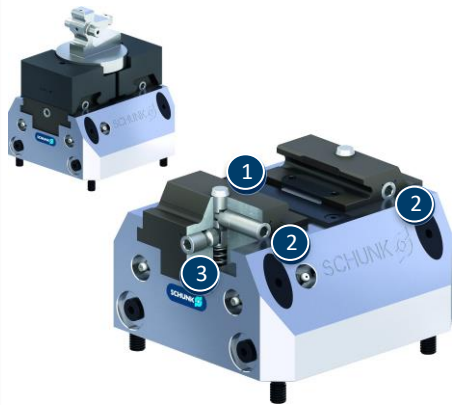

- 1 Locking pin for jaw mounting
- 2 Side access to changing mechanism
- 3 Front access to changing mechanism

# Variants of TANDEM KSP plus

Technical data	KSP plus 64			KSP plus 100			KSP plus 160			KSP plus 250		
	KSP	KSP-LH	KSP-F	KSP	KSP-LH	KSP-F	KSP	KSP-LH	KSP-F	KSP	KSP-LH	KSP-F
Stroke/jaw [mm]	2	4	4	2	6	4	3	8	6	5	15	10
Clamping force [kN]	4.5	2.3	4	18	8	18	45	20	45	55	20	55
Max. pressure [bar]	9	9	9	9	9	9	9	9	9	6	6	6
Repeat accuracy vise [mm]	0.01	0.01	0.01	0.01	0.01	0.01	0.02	0.02	0.02	0.03	0.03	0.03
Max. jaw height [mm]	60	120	60	60	150	60	60	200	60	150	500	150
Air consumption per double stroke at 6 bar [cm <sup>3</sup> ]	220	260	220	1000	1000	1000	3400	3400	3400	9000	9000	9000
Closing/opening time [s]	0.1	0.1	0.1	0.2	0.2	0.2	0.4	0.4	0.4	1	1	1
Weight [kg]	1.5	1.5	1.5	4	4	4	11	11	11	32	32	32

Superior Clamping and Gripping



© 2021 SCHUNK GmbH & Co. KG  
[schunk.com](http://schunk.com)