

# ZENTRICO LSW

Steady Rest Quick Change

Superior Clamping and Gripping



# Product overview



## Gripping Systems

## Clamping Technology



Chuck Jaws



Stationary Workholding



Lathe Chucks



Toolholders



Hydraulic Expansion Technology



Manual Lathe Chucks



Power Lathe Chucks with Jaw Quick-change System



Power Lathe Chucks with Through-hole



Power Lathe Chucks without Through-hole



Pneumatic Power Chucks



Steady Rests



Quick-change Systems



Customized Solutions

# Challenges

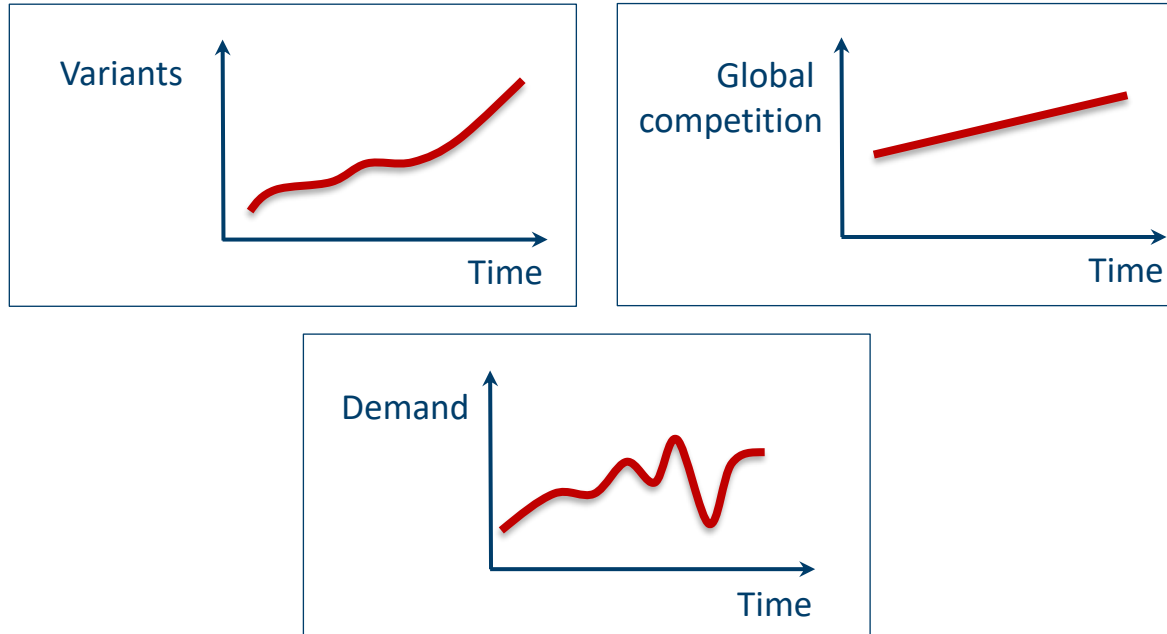

Flexibility and und set-up time optimization

# Overview

## Quick-change Systems

**ROTA FSW**



**ZENTRICO LSW**

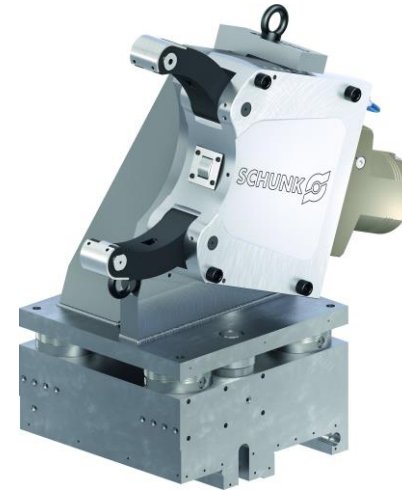

# ZENTRICO LSW

## Example of application



### Clamping device:

THL plus 310 with quick-change system on the basis of VERO-S.

### Features/Application:

Support of long, cylindrical workpieces on lathes. Optimum utilization of the machine room and highest flexibility thanks to the quick-change system.

# ZENTRICO LSW

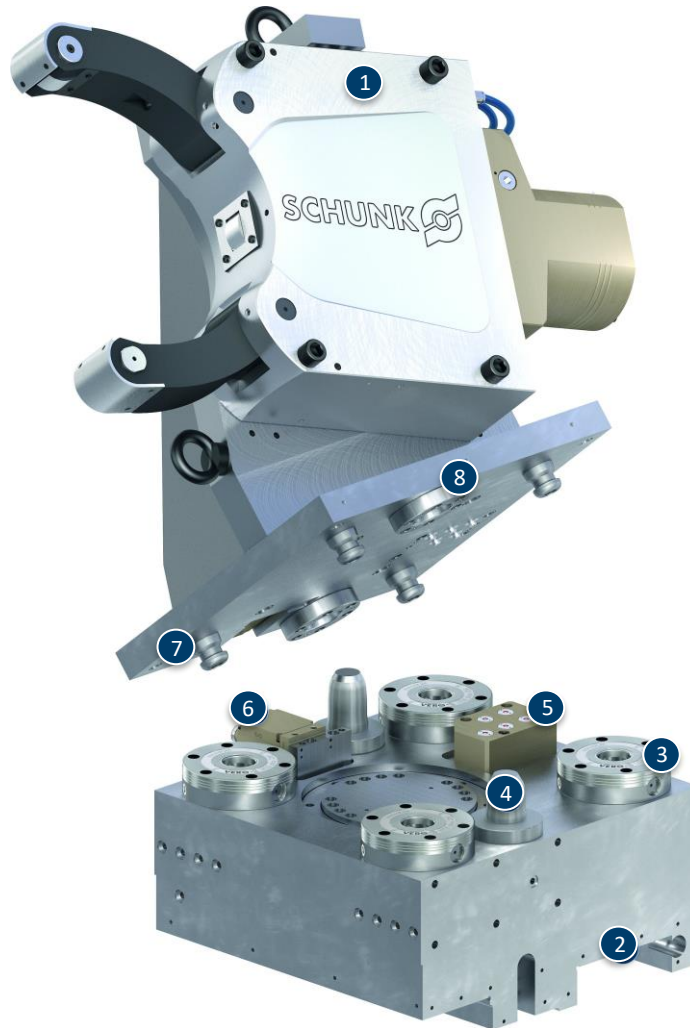

- ① Steady rest
- ② Machine interface
- ③ VERO-S NSE plus modules
- ④ Centering cones
- ⑤ Media transfer
- ⑥ Inductive monitoring and transfer of the electrical signal
- ⑦ Clamping pins
- ⑧ Centering ring

# SCHUNK Services

## Engineering

- Dimensioning of special plates designed to the manufacturing specifications
- Development of special solutions together with the customer
- FEM analysis for critical components

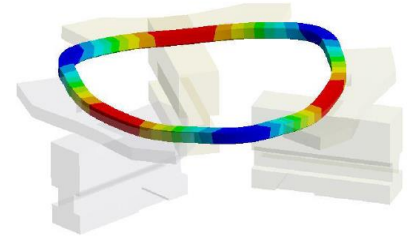

## Testing

- Endurance tests with all new developments
- Abrasion checking
- Measurement of accuracy



## Service

- Initial operation of customer's solution
- Inspection and maintenance
- Repairs

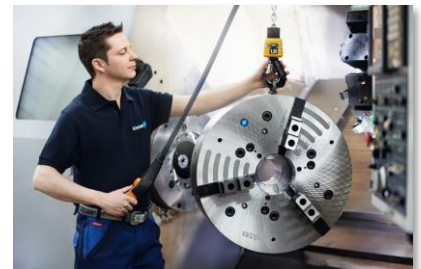

Superior Clamping and Gripping



© 2021 SCHUNK GmbH & Co. KG  
schunk.com