



# VERO-S NSE-A3

Versatile clamping module for automated machine loading

# VERO-S NSE-A3

## General information

- Integrated cone seal by default
- Integrated monitoring
- Integrated media transfer
- Integrated cleaning function
- Stepped flat surfaces
- Positioning via short taper
- Patented dual stroke system for highest pull-down forces
- Turbo integrated by default
- Form-fit, self-retained locking
- The modules are stainless and completely sealed
- All modules can be operated with a system pressure of 6 bar



# VERO-S NSE-A3

## Functional diagram

- 1 Standard cone seal
- 2 Anti-twist protection V4
- 3 Patented dual stroke system
- 4 Turbo function
- 5 Completely sealed system
- 6 Monitoring of the clamping slide position „open condition“ and „locked condition“
- 7 Stepped flat surfaces
- 8 Integrated media transfer



# VERO-S NSE-A3

## Highlights



### Centering via short taper

The precise short taper centering combined with the form-fit and self-retaining locking characterizes the SCHUNK quick-change pallet system.



### Locking via clamping slides

Large contact surfaces between clamping slides and clamping pin ensure a low surface pressure, resulting in a long service life.



### Cone seal integrated in the standard version

All clamping modules of the NSE-A3 series are equipped with a cone seal as standard. Due to this cone seal, the changing interface is reliably protected against the ingress of coolant, dust, and chips.

# VERO-S NSE-A3

## Highlights



### Rolling friction between piston and clamping slide

In order to further increase the pull-down force, the plain bearing bushings are integrated in the piston for bearing the cylinder pin. Therefore the efficiency is increased and wear minimizes at the same time.

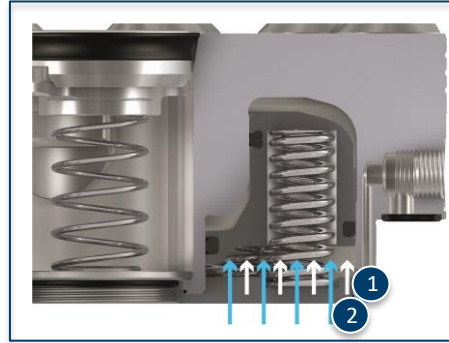

### Integrated turbo function

In order to increase the pull-down force, the quick-change pallet module is additionally actuated with compressed air → turbo-function influences the pull-down force

- 1 Spring force
- 2 Additional force



### Stepped flat surfaces

The clamping device or the workpiece is located on stepped flat surfaces of the quick-change pallet module. This ensures clean and ideal support for transmitting high torques.

# VERO-S NSE-A3

## Highlights



### Cleaning and monitoring of the flat work surface

All NSE-A3 plus clamping modules have integrated contact monitoring as standard. The contact surface is cleaned when loading the pallet. → reliable sequence



### Monitoring of the clamping slide position – opened condition

- 1 **Deaeration:** Compressed air can escape because the clamping slide is not positioned above the bore hole.
- 2 **Dynamic pressure:** Compressed air cannot escape because the clamping slide is above the bore hole.



### Monitoring of the clamping slide position – locked condition

- 1 **Dynamic pressure:** Compressed air cannot escape because the clamping slide is above the bore hole.
- 2 **Deaeration:** Compressed air can escape because the clamping slide is not positioned above the bore hole.

# VERO-S NSE-A3

## Highlights



### Control of the quick-change pallet system

The modules are actuated via lateral or bottom air connections.

**Benefit:** The module is versatile in installation.



### Hermetically sealed – maintenance-free

The cover plate at the lower piston chamber seals the system off completely.

**Benefit:** No penetration of chips, dirt or coolant. The module is maintenance-free.

# VERO-S NSE-A3

## Highlights



### Made of stainless steel – long service life

All functional components are made of hardened stainless steel.



### Pressure spring made of stainless steel

For maximum service life, all of the actuating springs are made of fatigue-free stainless steel.

# VERO-S NSE-A3

## Fast and Clamping Stroke – the Patented Force

- ① Clamping stroke
- ② Jaw fast stroke
- ③ Y-axis
- ④ X-axis
- ⑤ Actuation force
- ⑥ Force on the clamping slide
- ⑦ Pull-down force on the clamping pin

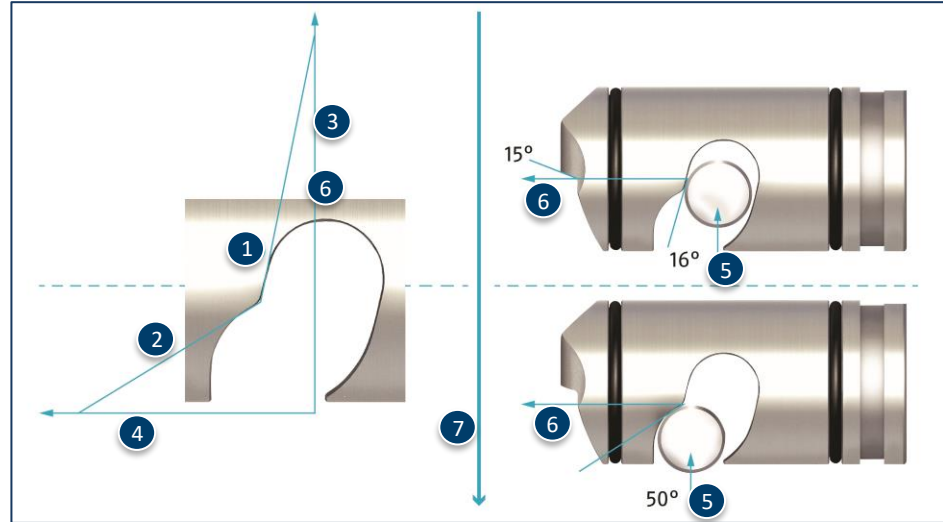

# VERO-S NSE-A3

## Fast and Clamping Stroke – the Patented Force

- ① Actuation force of the spring force clamping
- ② Actuation force of the turbo function
- ③ Pull-down force of the spring force clamping
- ④ Pull-down force of the turbo function
- ⑤ Y-axis
- ⑥ X-axis

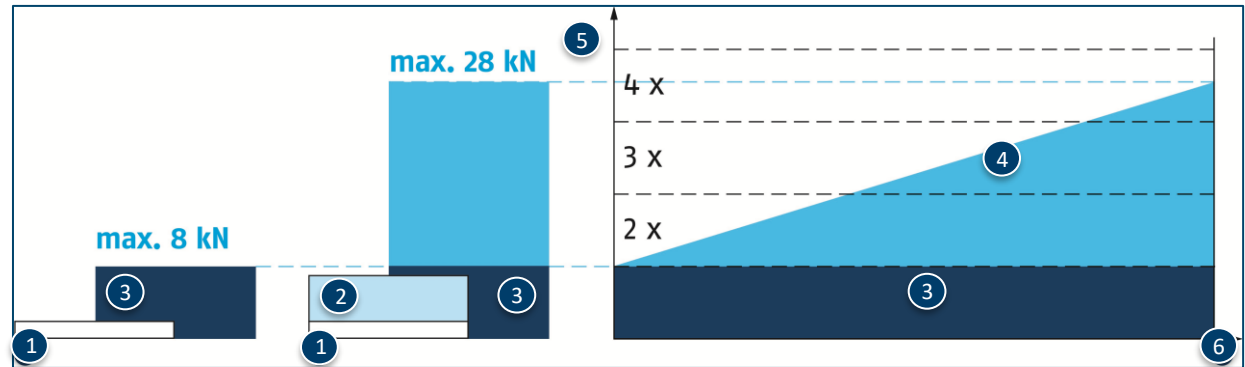

Superior Clamping and Gripping



© 2021 SCHUNK GmbH & Co. KG  
[schunk.com](http://schunk.com)