

Montage- und Betriebsanleitung Installation- and operating instruction

5-Achs-Spanner mit Schnellwechselbacken 5-axis-vice with quick-change jaws

KSX-C2



H.-D. SCHUNK GmbH & Co.
Spanntechnik KG
Lothringer Strasse 23
D-88512 Mengen

Table of contents:





1	User information	24
1.1	Purpose of document	24
1.2	Illustration of safety features	24
2	General safety instructions	25
2.1	Intended use	25
2.1.1	Technical data	25
2.2	Reasonably foreseeable misapplication	26
2.2.1	Alterations and modifications.....	26
2.2.2	Spare and wear parts and auxiliary material.....	26
2.3	Residual risk	27
2.3.1	Jaw change	27
2.3.2	Notes on clamping technology.....	27
2.4	Duties of the organisation in charge.....	27
2.5	Operator duties.....	28
2.6	Operator qualification	28
2.7	Personal protective equipment.....	28
2.8	Warranty	28
3	Description	29
3.1	Function.....	29
4	Operation	30
4.1	Aligning / Fastening	30
4.2	Jaw range	31
4.3	Fitting the system jaws	31
5	Clamping procedure	32
5.1	Precision clamping (without lifting)	32
5.2	Raw workpiece clamping (with lift-off)	33
6	Servicing, cleaning and maintenance	34
6.1	Removing / Assembly of the spindle.....	35
6.2	Cleaning the spindle	35
7	Assembly drawing	36
7.1	Parts list.....	36
8	Pull rod extension	37
9	Swivel and adapter plate	38
9.1	Function.....	38
9.2	Servicing, cleaning and maintenance.....	38
9.3	Troubleshooting / Eliminating faults	38
9.4	Removing and replacing parts	39
9.5	Fitting the 6-fold reversible jaws.....	39
10	Steel jaws soft	40
11	Precision jaws set	40
12	KSX-C2 125 hydraulic	41
12.1	Function.....	41
12.2	Risks of hydraulic system	42
13	Pull rod extension	42
14	Taking out of service	42
15	EC declaration of incorporation	43

1 User information

1.1 Purpose of document

These instructions are an integral part of the product supplied and contain important information for the safe installation, commissioning, operation, servicing and maintenance. These instructions must be read before using the product and must be observed during operation, in particular the "General safety instructions" section.

1.2 Illustration of safety features

DANGER	
	<p>Indicates imminent danger. If the information is ignored, death or serious injury (permanent disability) will result.</p>
WARNING	
	<p>Indicates a potentially dangerous situation. If the information is ignored, it is possible that death or serious injury (permanent disability) will result.</p>
WARNING	
	<p>Indicates a potentially dangerous situation. If the information is ignored, it is possible that material damage and light to medium injury will result.</p>
NOTE	
	<p>Indicates general information, useful tips for users and work recommendations which do not impact on the health and safety of operators. ... underscores useful tips and recommendations as well as information for efficient and trouble-free operation.</p>
CAUTION	
	<p>Indicates a potentially dangerous situation. If the information is ignored, material damage will result. ... points out a potentially dangerous situation that can lead to material damage if it is not avoided.</p>

2 General safety instructions

2.1 Intended use

The clamping device may only be used in accordance with the technical data and has been designed for stationary application on milling machines in an industrial environment.

Using the device in accordance with the intended purpose includes compliance with the commissioning, installation and operating instructions, and with the environmental and service conditions as provided by the manufacturer.

The manufacturer accepts no liability for damage resulting from non-intended use.

2.1.1 Technical data

Version	max. torque	max. clamping force
KSX-C2 125 Raw part clamping	100 Nm	50 kN
KSX-C2 125 Precision clamping	120 Nm	40 kN
KSX-C2 125-L Raw part clamping	100 Nm	50 kN
KSX-C2 125-L Precision clamping	120 Nm	34 kN

Raw part clamping KSX-C2 125 and KSX-C2 125-L

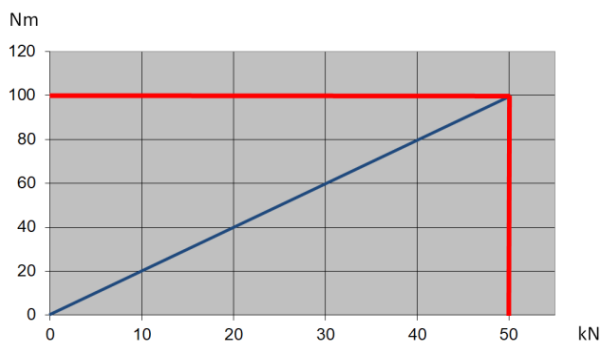

Precision clamping KSX-C2 125

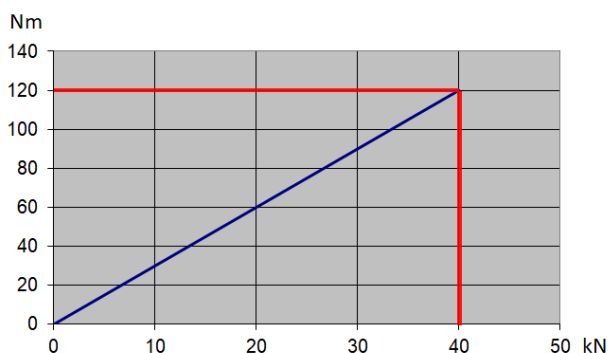

Precision clamping KSX-C2 125-L

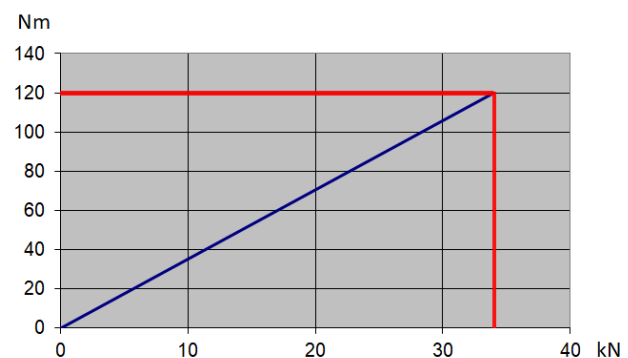

Exceeding the max. torque results in damage to the spindle.



Weight:

KSX-C2 125-330 without system jaws:	33.2 kg
KSX-C2 125-430 without system jaws:	36.1 kg
KSX-C2 125-500 without system jaws:	38.1 kg
KSX-C2 125-630 without system jaws:	41.8 kg
KSX-C2 125-800 without system jaws:	46.6 kg

KSX-C2 125-330-L without system jaws:	27.3 kg
KSX-C2 125-430-L without system jaws:	30.2 kg
KSX-C2 125-500-L without system jaws:	32.2 kg
KSX-C2 125-630-L without system jaws:	35.9 kg
KSX-C2 125-800-L without system jaws:	40.7 kg

For further data, please see homepage >> schunk.com <<

2.2 Reasonably foreseeable misapplication

Any application that is not in accordance with the "Intended use" or exceeds such intended use is considered not in accordance with the regulations, and is forbidden. Any other use of the device is subject to confirmation from the manufacturer.



Examples of foreseeable misapplication

- Clamping device used on rotating systems.
- Clamping widely protruding workpieces.
- Clamping workpieces with a weight of over 20 kg in vertical position without an additional protection against the workpiece falling out as a protective measure for the operator.

2.2.1 Alterations and modifications

In the case of unauthorised alterations and modifications of the clamping device, the manufacturer's liability ceases and any warranty is voided.

2.2.2 Spare and wear parts and auxiliary material

Only use original parts or parts approved by the manufacturer. Using spare and wear parts by third party manufacturers may lead to risk.

2.3 Residual risk



The user is responsible for applying the correct workpiece clamping.
New clampings have to be carefully checked by qualified personnel with relevant training.
One always needs to allow for the risk that the workpiece may slip or be dislodged, even when the clamping device is functioning correctly. This is due to the different geometries to be clamped, contact surfaces, clamping friction values, processing force, wrong manipulation of the milling machine etc.
Protective devices are to be attached to the processing machine that will protect the operator from any tool or workpiece parts that may be ejected.
It is mandatory that operators and others in the proximity of the processing machine wear protective goggles.
Do not use methods of operation that impair the function and operational safety.

2.3.1 Jaw change

Damage may result if system jaws are insufficiently fastened.



2.3.2 Notes on clamping technology

The operator is responsible for ensuring that the clamping geometry and clamping forces are suitable for the intended processing.
The clamping forces can only be achieved if the clamping device functions correctly and the workpiece is correctly held in the device.
Regular servicing and cleaning in accordance with the operating instructions is mandatory in order to ensure correct function.
When clamping thin-walled elastic workpieces, e.g. tubes or packages, it is possible that the clamping force is significantly reduced due to yielding of the workpiece.

2.4 Duties of the organisation in charge

The organisation in charge of the device undertakes to only allow operatives to work on the device:

- who are familiar with the basic health and safety regulations and regulations for the prevention of accidents.
- who have completed appropriate induction for working with the machine.
- who have read and understood these operating instructions.

The requirements of the EC Directive 2007/30/EC on the use of work machinery must be complied with.

2.5 Operator duties

All persons who have been instructed to work with the machine undertake to:

- observe the basic regulations for health and safety and for the prevention of accidents.
- read and understand the section on safety and the safety instructions in these operating instructions prior to working with the machine, and to observe these instructions.

2.6 Operator qualification

The installation, initial setup, fault analysis and periodic monitoring have to be carried out by competent personnel with the relevant qualifications.

2.7 Personal protective equipment

WARNING	
	<p>Ejected hot fragments can lead to serious eye injury. The regulations for safety at work and the prevention of accidents always have to be observed when working with the machine.</p> <p>Personal protection equipment must be worn at all times, in particular safety boots, gloves and safety goggles.</p>

2.8 Warranty

Warranty	24 months
Maximum service life	50'000 clamping cycles

The warranty period is valid from the date of delivery ex-works, provided the machine is used as intended and subject to the following conditions:

- Compliance with the concurrent documents.
- Observance of environmental and work conditions.
- Observance of the specified servicing and lubrication intervals.
- Observance of the maximum service life.

Parts in contact with the workpiece are not covered by the warranty.

3 Description

The KSX-C2 has been designed for clamping unprocessed and processed workpieces. The clamping force is generated mechanically and the clamping force transmission is linear across the whole clamping range.

The spindle is protected against dirt thanks to complete encapsulation.

Raw parts clamping with jaw lift-off

At 100 Nm torque is the clamping force 50 kN.

Precision clamping without jaw lifting

At 120 Nm torque, the clamping force is 34 kN for the S version and 40 kN for the standard version.

Improper use and clamping with too high torques will cause damage to the spindle and jaws.



3.1 Function

The clamping range can be quickly adjusted by turning the spindle with a hand crank.

The KSX-C2 can be extended for an even larger clamping range with additional pull rod extensions.

4 Operation

4.1 Aligning / Fastening

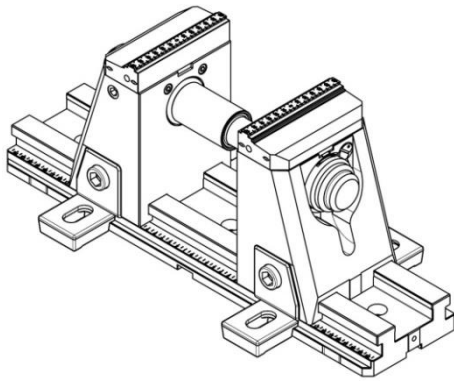

Fastening with cylinder screw M12 through the countersunk holes (3) on the T-slot machine table with a pitch of 100 mm or with clamping claws.

Important:

Up to a base body length of 500 mm, ensure a symmetrical distance of the two clamping claws is 100 to 150 mm.

For a base body length of 630 mm, use at least six clamping claws with a distance of 150 mm or 200 mm for the length 800 mm.

Alignment with alignment pins (1), precision sliding blocks (2) or fitting screws (4).

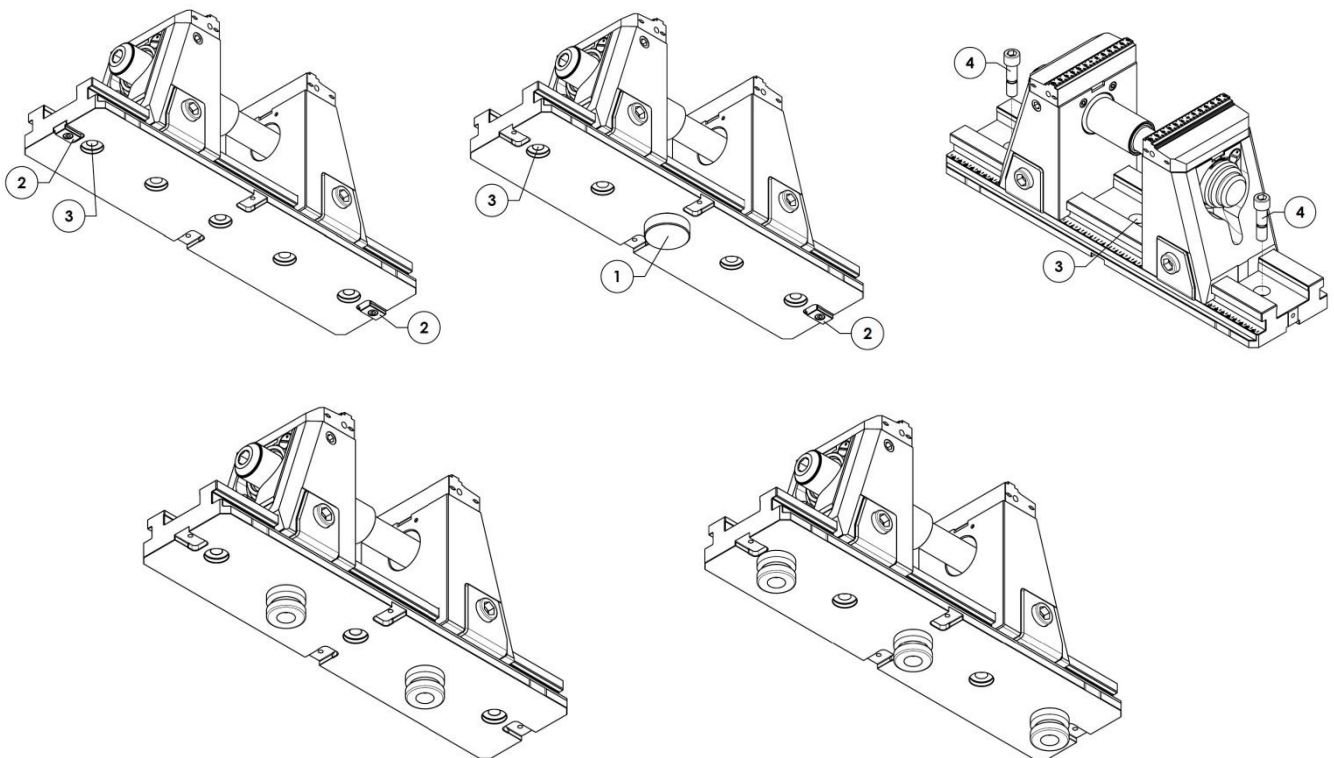

Locating holes $\varnothing 25$ H7 to attaching the clamping pins for NSE3 and GFD quick-change pallet systems.

4.2 Jaw range

The reliable function of the clamping device is significantly affected by the selection of the correct system jaws.

4.3 Fitting the system jaws

Basically, no tools are necessary for assembly.

The system jaws are clicked in from above via a quick-change system 1 and can be rotated 180°.

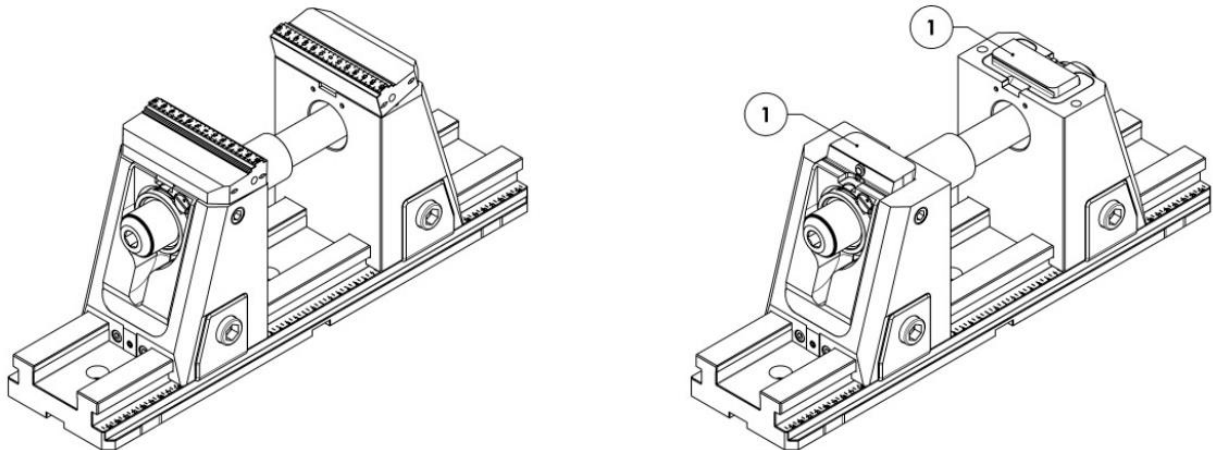

To remove the system jaws, we recommend turning a screwdriver in the opening under the system jaw to the jaw clicks out.

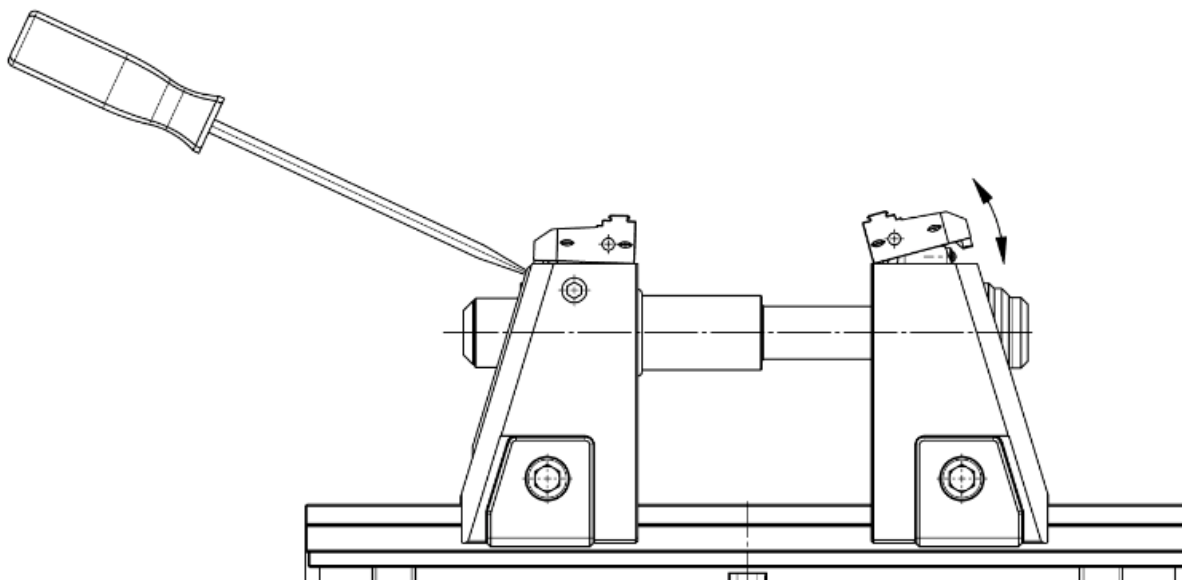

5 Clamping procedure

5.1 Precision clamping (without lifting)

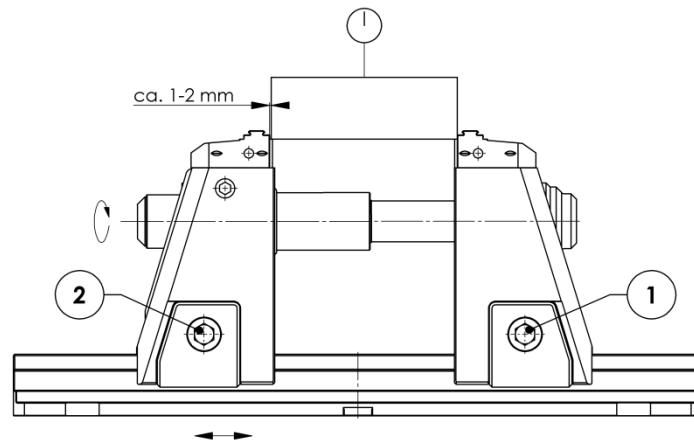

- Position fixed support jaw and tighten the cylinder screw 1 with a torque of 140 Nm.
- The clamping range is adjusted with the movable support jaw by placing the system jaw 1-2 mm in front of the workpiece.

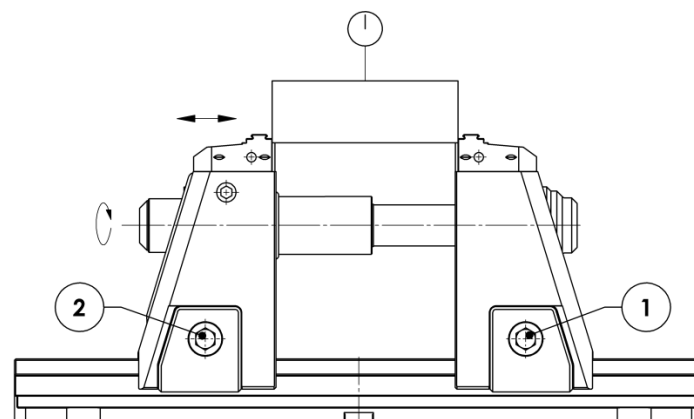

- Tighten the cylinder screw 1 at the movable support jaw with a torque of 140 Nm.
- Clamp the workpiece on the spindle with the desired clamping force.

Important:

The cylinder screw must be tightened to 140 Nm and it must not be clamped without the workpiece, as otherwise the carrier jaws could shift and could damage the base body.



Precision clamping KSX-C2 125

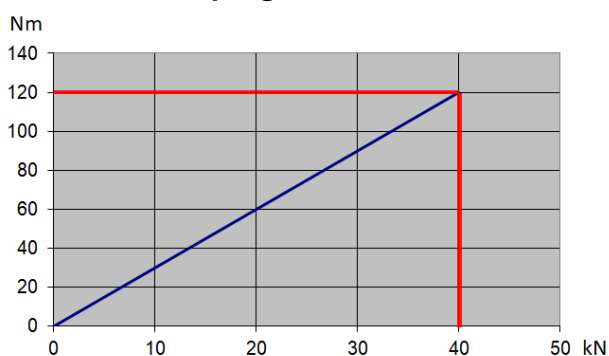

Precision clamping KSX-C2 125-L

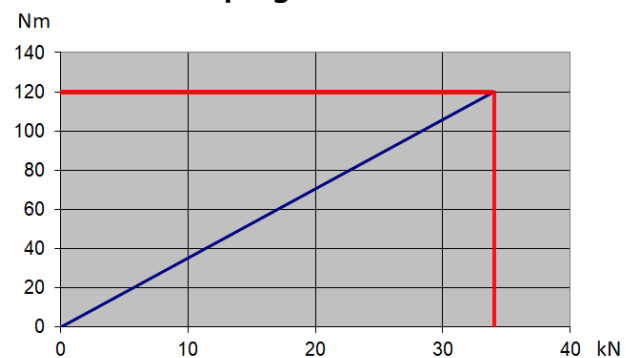

Attention:

When releasing the workpiece from precision clamping, ensure you do not open the spindle too far. Over-opening spindle can damage the spindle lock and cause to a defect in the vice, as the clamping lever has a max. stroke of 4 mm.

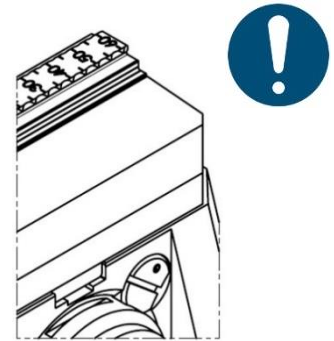

5.2 Raw workpiece clamping (with lift-off)

With the raw part clamping it is possible to clamp with simpler set-up and greater clamping forces.

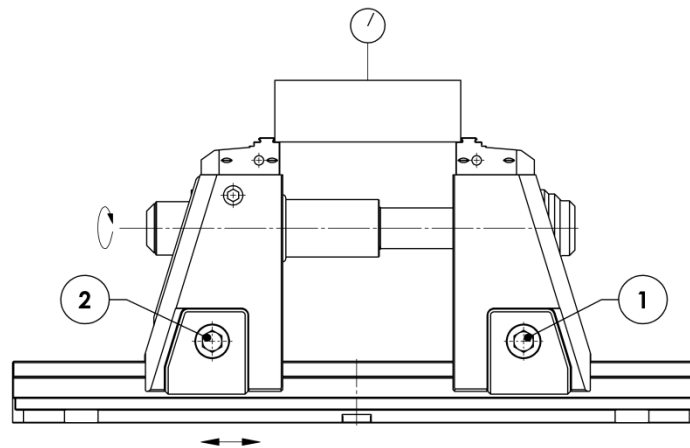

- Position fixed support jaw and tighten the cylinder screw 1 with a torque of 140 Nm.
- Cylinder screw 2 at the movable support jaw remains loose and workpiece is clamped with the desired clamping force.

Important:

Significantly higher clamping forces are achieved with the raw workpiece clamping. Make sure that the torque of 100 Nm is not exceeded to overload the clamping system in the long run.



Raw part clamping KSX-C2 125 and KSX-C2 125-L

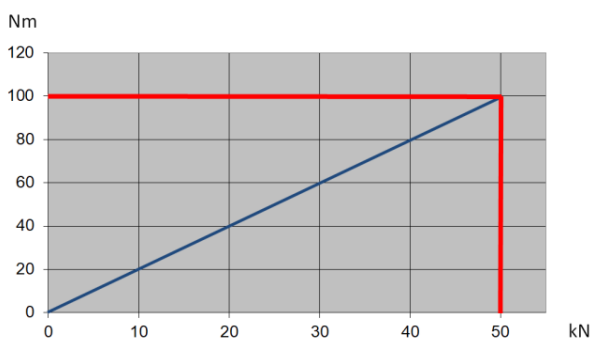

6 Servicing, cleaning and maintenance

Lubricate the running and contact surfaces of the system and support jaws with highpressure grease every two weeks.

Remove the support jaw out of the working position and grease the guides of the moving support jaw at regular intervals or every two weeks.

When changing pull rod extensions, ensure sufficient lubrication.

If creaking noises occur during operation, lubricate the spindle dry-running guides immediately.



Cleaning / Lubrication

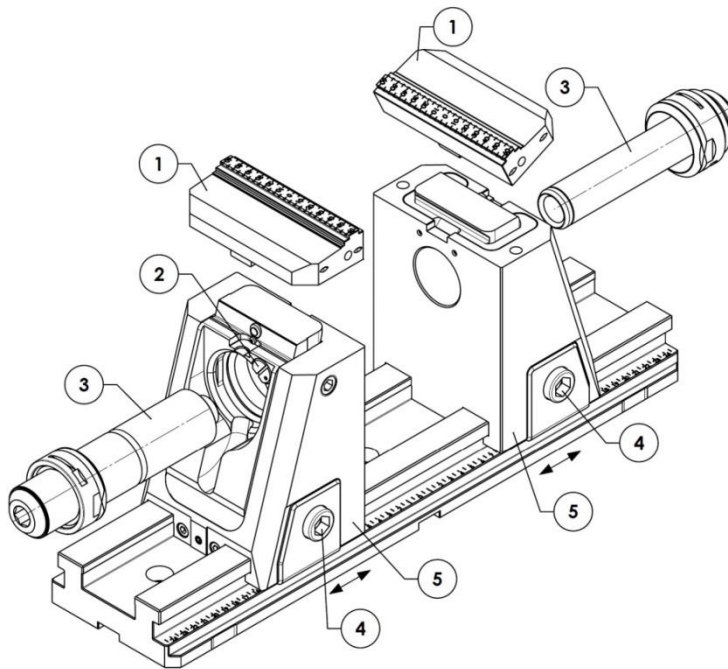

- Remove the system jaws (1).
- Release the lock (2) and remove the spindle. (3)
- Loosen the carrier jaws (5) (4) and extend.
- Clean and oil the base body guide surfaces.
- Refit the carrier jaws. (5)
- Clean and grease the thread (3) and reinstall.
- Clean and grease the contact surfaces of the system jaws and click in the system jaws. (1)

6.1 Removing / Assembly of the spindle

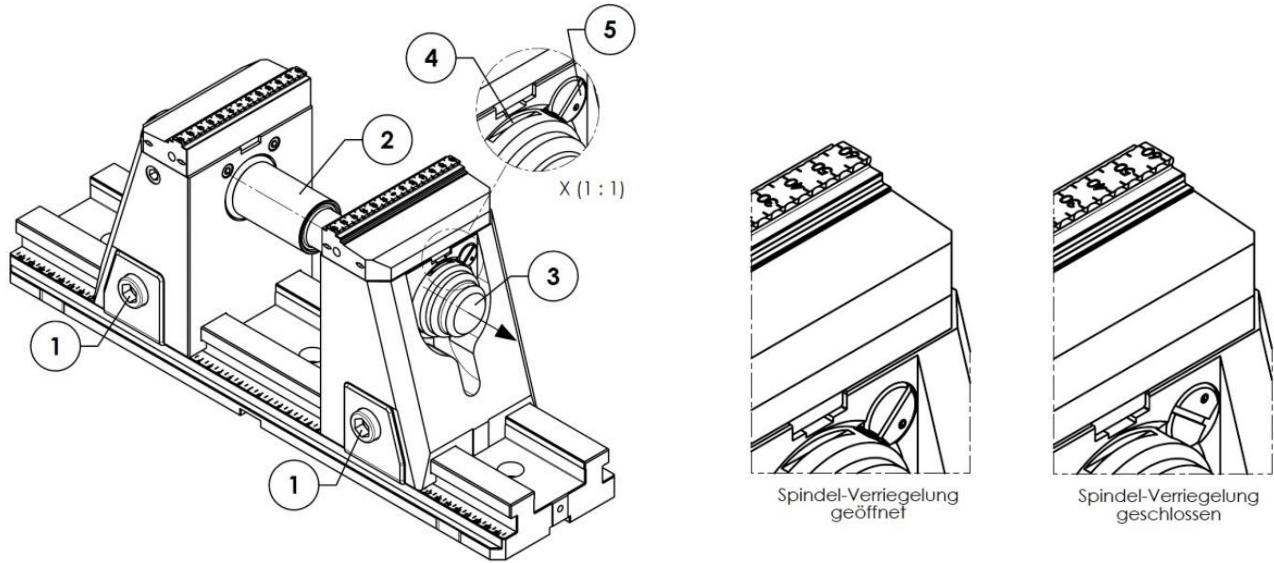

- Both carrier jaws (1) must be clamped and the rear lock (5) released.
- Both support jaws (1) must be clamped.
- Turn the spindle (2) until the pull rod extension (3) is pressed out of the support jaw.
- Remove the pull rod extension (3).
- Place screwdriver in groove (4) and pull the spindle (2) out of the support jaw.
- The procedure can also be performed by releasing the lock (5) of the spindle (2) and pushing the spindle (2) out first.

6.2 Cleaning the spindle

- Unscrew the spindle completely.
- Clean and lubricate with high pressure grease.
- When assembling, make sure that the seal is seated correctly.

Stroke limitation

The spindle is completely encapsulated and the maximum stroke is marked (3).

Important:

The thread must not be turned above the limit line marking (3), as a spindle that is opened too far can break out during clamping.



7 Assembly drawing

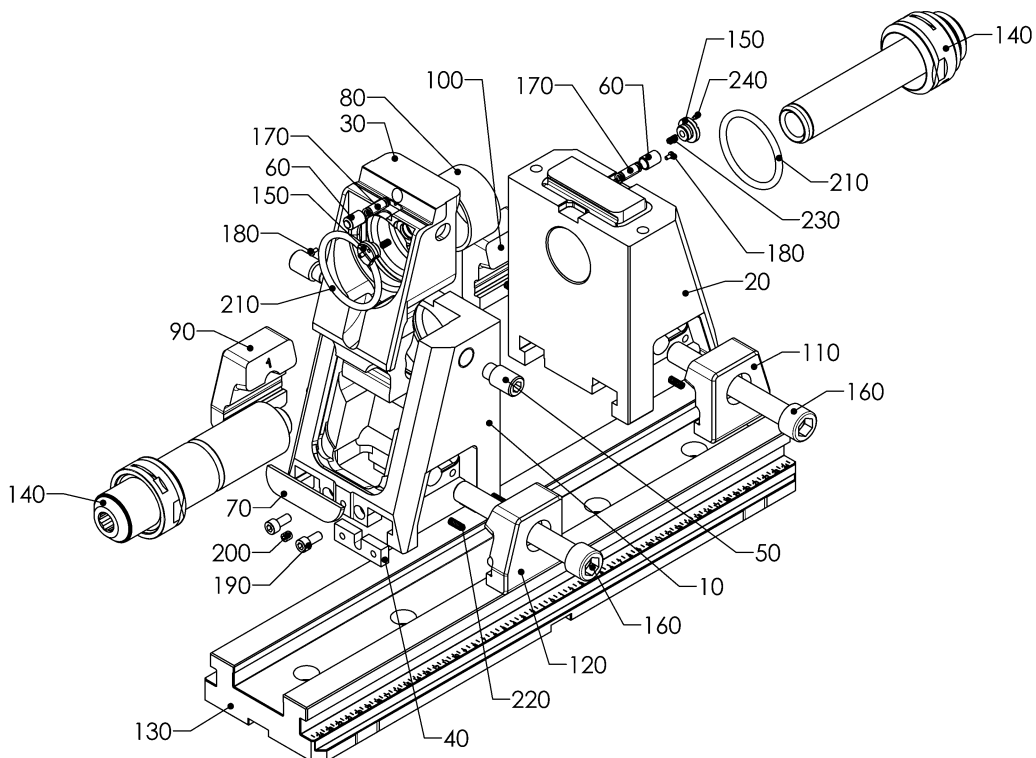

7.1 Parts list

Position	Designation	Quantity
10	Support jaw mobile	1
20	Support jaw fix	1
30	Clamping lever	1
40	Position holder	1
50	Internal hexagon threaded pin M16x30	2
60	Pressure piece	2
70	Damper	1
80	Damper	1
90	Bracket left with thread	1
100	Bracket right with thread	1
110	Bracket left with counterbore	1
120	Bracket right with counterbore	1
130	Base body	1
140	Spindle	1
150	Spindle lock	2
160	Internal hexagon cylinder screw M16x120 12.9	2
170	Spiral spring 1.40x5.70x22.00	2
180	Lens head screw torx M2.5x5	2
190	Internal hexagon cylinder screw M6x14	2
200	Internal hexagon threaded pin M6x6	1
210	O-ring NBR/70 53.00x5.00	2
220	Spiral spring 1.00x5.0x17.3	8
230	Spiral spring 0.90x3.60x9.70	2
240	Internal hexagon threaded pin ZA Ø2.5x6	2

8 Pull rod extension

Removing / Installation

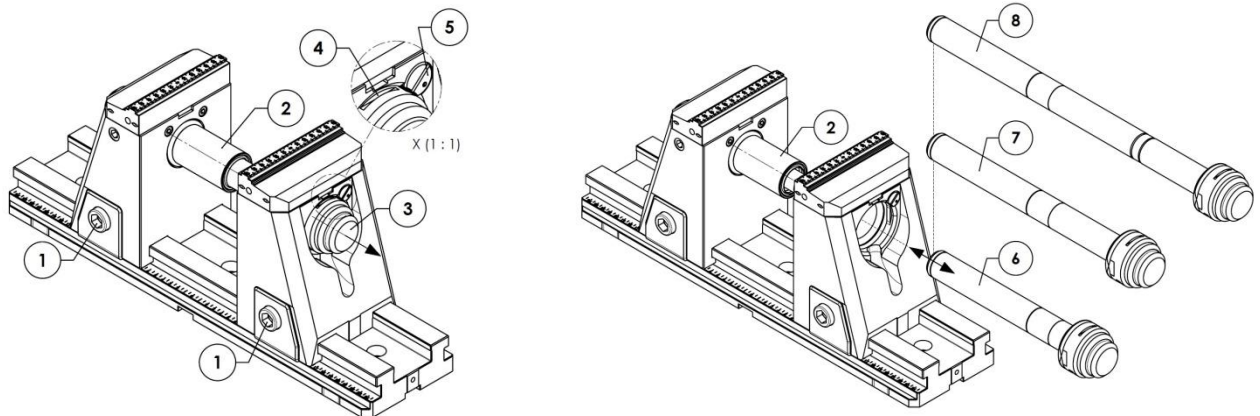

- Both carrier jaws (1) must be clamped and the rear locks (5) released.
- Turn the spindle (2) until the pull rod extension (3) is pressed out of the support jaw.
- Remove the pull rod extension. (3)
- Release clamping claws. (1)
- Insert the pull rod extension (5, 6 or 7), screw on and close the lock. (5)
- Position carrier jaws and tension the clamping claws (1) with 140 Nm.

9 Swivel and adapter plate

9.1 Function

Slanted and curved items can be securely clamped with 4-point clamping using the swivel plate system.

The swivel plate is pulled downwards during the clamping process due to its conical swivel plate bearings, this means that the swivel plate is not likely to lift off.

With the 6-fold reversible jaw it is possible to cover numerous clamping solutions in a straight-forward way. A total of six different clamping sides are available, at the four sides of the jaw as well as at two places with a convex "grip" profile.

It is also possible to carry out two-sided processing using the tungsten carbide coated side of the 6-fold reversible jaw.

Processing the first side

For unprocessed part clamping using the 6-fold reversible jaw, five different "grip" clamping sides are available with a clamping depth of 3, 8 and 18 mm.

Processing the second side

Clamping with the tungsten carbide coated side of the 6-fold reversible jaw.

It is important to take into account that during the first clamping process, the 6-fold reversible jaws can yield slightly until the play in the peg seating is eliminated.

The workpiece position must be measured, the zero point should not be determined until after 3 to 5 power clampings.

Important:

Max. 3° rotating.



Handling the demounted swivel plate

When handling the swivel plate, it should not be turned upside down as the peg fall out.



9.2 Servicing, cleaning and maintenance

The upper shoulder of the swivel peg must be cleaned and greased regularly.

9.3 Troubleshooting / Eliminating faults

Swivel plate is difficult to turn

- Disconnect the swivel plate and push the swivel peg from below out of the swivel plate.
- Check the jaw fixing and swivel plate surface for indentations or deformations. If necessary, re-grind the plate and the jaw fixing.
- Check the peg for soiling.
- Lubricate the entire system with grease and reassemble.

Swivel plate wobbles

- Check whether marking (R) on the swivel peg and the swivel plate points outside. If not, turn swivel plate / swivel peg.

9.4 Removing and replacing parts

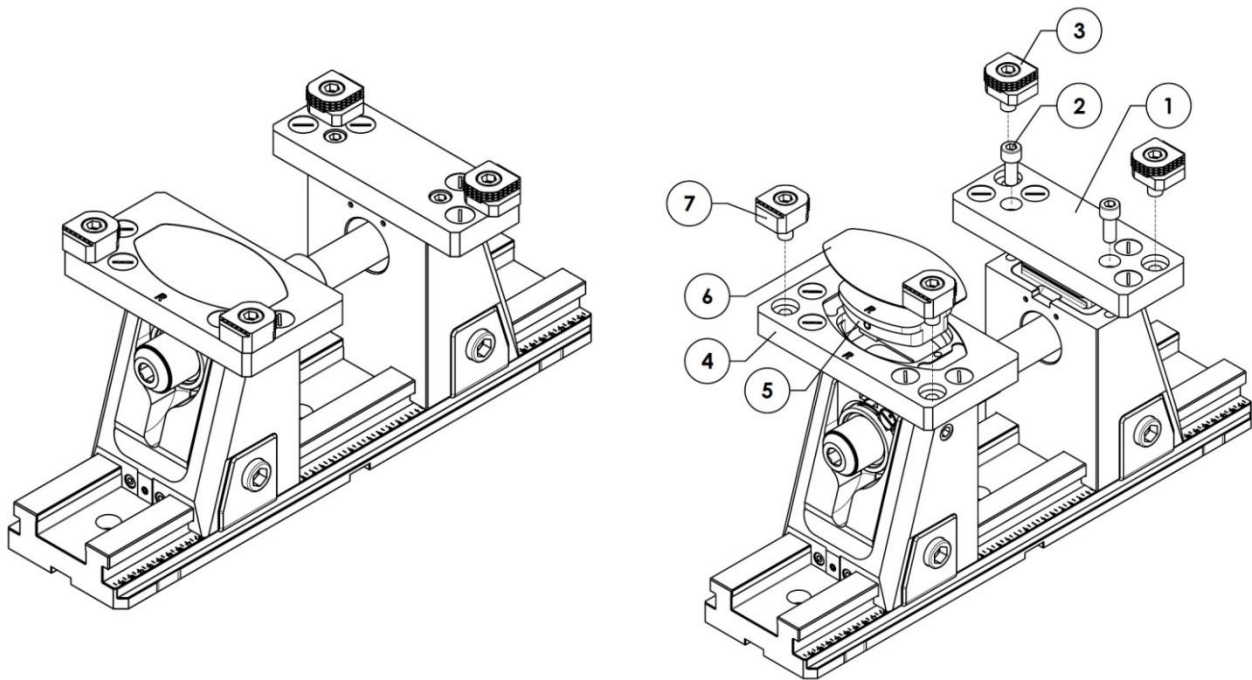

- Release the two cylinder screws. (2)
- Remove the adapter and swivel plate.
- Clean and oil the contact surfaces, e.g. with MOTOREX Supergliss 68 K.
- Place the adapter plate (1) on the fixed jaw.
- Tighten the two cylinder screws (2) with 40 Nm.
- Engage the swivel plate (4) and the swivel peg (5) in the clamping lever and check whether marking (R) on swivel peg and swivel plate points outside.
- Fit the cover plate.

9.5 Fitting the 6-fold reversible jaws

- Determine the mounting positions of the 6-fold reversible jaws.
The best clamping results are achieved when workpieces as far out as possible.
- Move the cover screws so that the selected clamping position is available.
- Position the 6-fold reversible jaws and loosely insert the cylinder screws.
- Turn the 6-fold reversible jaws on to the required clamping faces and slightly pre-clamp the workpiece with the clamping jaws so that the clamping faces are parallel to, and touch, the workpiece.
- Use a torque of 80 Nm to tighten the cylinder screws of the 6-fold reversible jaws.

Important:

When the clamping faces of the 6-fold reversible jaws are not aligned parallel to the workpiece surface it is possible that the 6-fold reversible jaw becomes loose through the clamping force.



10 Steel jaws soft

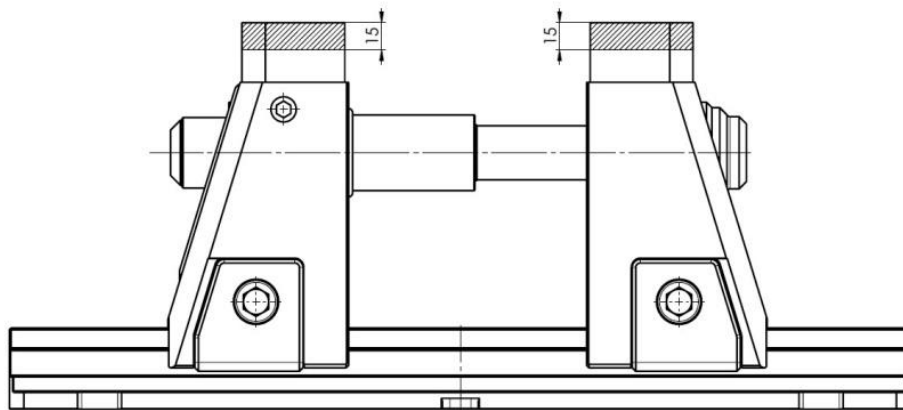

Important:

Max. milling depth 15 mm.



11 Precision jaws set

The precision jaws must be hard-milled in the precision clamping with 60 Nm clamping force according to the views.

For machining in the standard position must the supplied reference tip and for the VS position a gauge block used.

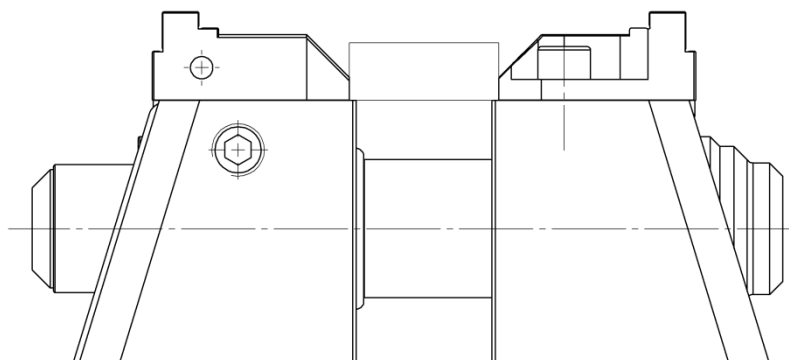
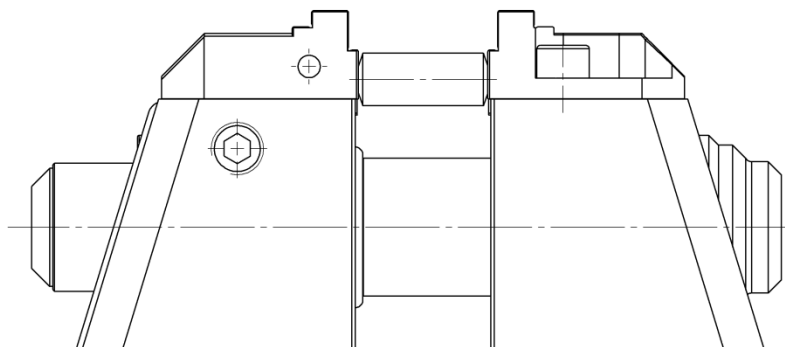

Important:

Max. milling depth 0.15mm (+/-0.1mm)



12 KSX-C2 125 hydraulic

12.1 Function

Instead of the and spindle assembly is a hydraulic spindle with spring reset fitted and the power supply of the cylinder via a hydraulic unit with pressure regulator by the customer.

The force is set via an external pressure controller in accordance with the diagram.

Depending on the clamping range must the short or long hydraulic cylinder be installed.

The clamping force is generated hydraulically and the clamping force transmission is linear across the whole clamping range.

Version	max. clamping force	max. clamping stroke	Oil-volume (by max. stroke)
KSX-C2 125 Raw part clamping	50 kN	4 mm	10 cm ³
KSX-C2 125 Precision clamping	40 kN	4 mm	10 cm ³
KSX-C2 125-L Raw part clamping	30 kN	4 mm	10 cm ³
KSX-C2 125-L Precision clamping	25 kN	4 mm	10 cm ³

Raw part clamping KSX-C2 125 and KSX-C2 125-L

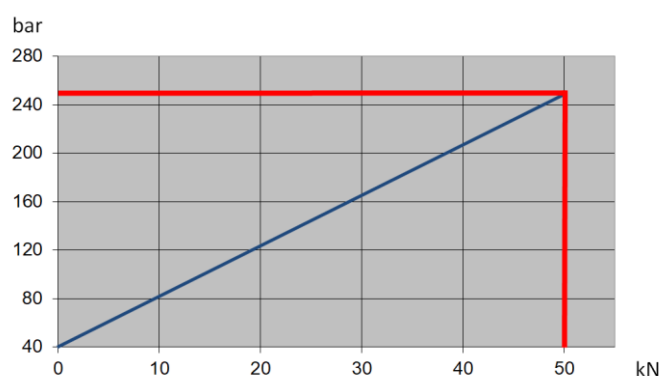

Precision clamping KSX-C2 125

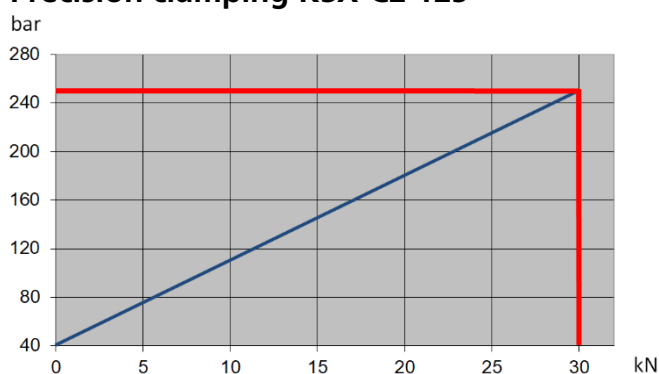

Precision KSX-C2 125-L

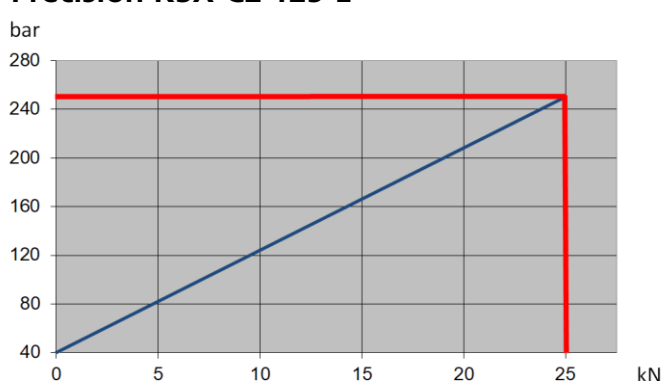

Exposure to loads in excess of the max. hydraulic pressure of 250 bar results in damage to the spindle.



Recommended operating medium:

Hydraulic oil HLP 15 – HLP 46

Important:

The hydraulic supply hose must be vented before connecting it to the vice.

Once the hose is connected, carry out some clamping actions without workpieces.



12.2 Risks of hydraulic system

Do not any manipulation when the system is under pressure.



Risk of fingers being caught during clamping

Set the clamping range such that the distance between the jaws is approx. 1 – 2 mm larger than the workpiece, this means that the gap is so small that fingers cannot be trapped.

Do not operate the vice with a gap between the workpiece and the jaws on either side that is large enough for fingers to be trapped in order to avoid accidents when the vice clamps the workpiece.



Choose a width between jaws that is clearly larger or clearly smaller.

When producing purpose-made jaws or when using aluminium jaws, it is important to avoid ridges that could present a trapping risk.

Maintaining pressure during operation

It is possible that hydraulic cylinders have small leaks.

During milling work, the clamping device must be continuously supplied with hydraulic pressure from the hydraulic system in order to ensure that there is no loss of pressure due to leakage.

Hydraulic hoses must be protected against hot fragments and the hoses must be regularly checked for wear.

Important:

If the hydraulic system loses pressure or a hose is damaged, the clamping force reduces sharply.

To avoid pressure drops due to switching operations of neighbouring switching valves or due to system failure of the hydraulics, we recommend at least installing a non-return valve before the switching valve (P inlet).



Ideally, a pilot-operated check valve should be installed directly before the clamping device.

For pallet systems that are depressurized during changeover, we recommend using a pilot-operated check valve to prevent the clamp from opening when pressure is released.

The vise must be regularly checked for leaks.

13 Pull rod extension

Removing / Installation

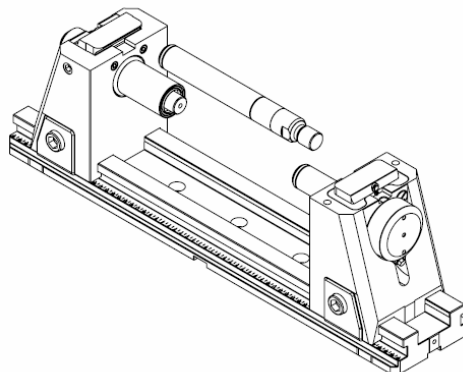

- Turn the spindle completely out of the adjustment spindle.
- Screw the pull rod extension into the adjusting spindle and tighten with 50 Nm.
- Screw the spindle into the pull rod extension.

14 Taking out of service

The clamping device and all accessories can be disposed of as scrap metal without any risk.

15 EC declaration of incorporation

In terms of the EC Machinery Directive 2006/42/EC, Annex II, Part B

Manufacturer H.-D. SCHUNK GmbH & Co.
 Distributor Spanntechnik KG
 Lothringer Str. 23
 D-88512 Mengen

We hereby declare that the following product:

Product designation: Single vice, hydraulic
 KSX-C2 125-H, KSX-C2 125-L-H
 ID-Number: 1493614, 1493616, 1493617, 1493620, 1493621, 1493622,
 1493624, 1493625, 1493627, 1493628

meets the applicable basic requirements of the **Machinery Directive (2006/42/EC)**.

The incomplete machine may not be put into operation until conformity of the machine into which the incomplete machine is to be installed with the provisions of the Machinery Directive (2006/42/EC) is confirmed.

Applied harmonized standards, especially:

EN ISO 12100:2011-03 Safety of machinery - General principles for design - Risk assessment and risk reduction

EN 62079:2001 Preparation of instructions - Structuring, content and presentation

The manufacturer agrees to forward on demand the special technical documents for the incomplete machine to state offices.

The special technical documents according to Annex VII, Part B, belonging to the incomplete machine have been created.

Person responsible for documentation: Mr. Philipp Schröder,
 Adress: see adress of the manufacturer

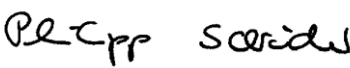

Mengen, September 2025

i.V. Philipp Schröder; Director for Development

H.-D. Schunk GmbH & Co.
Spanntechnik KG
Lothringer Strasse 23

D-88512 Mengen

Tel.: +49-7572-7614-1300
Fax: +49-7572-7614-1039

CMM@de.schunk.com
schunk.com