

Software manual
MTB application kit for ABB Robotics
SCHUNK software module for ABB

Translation of original software
manual

Imprint

Copyright:

This manual is protected by copyright. The author is SCHUNK SE & Co. KG.
All rights reserved.

Technical changes:

We reserve the right to make alterations for the purpose of technical improvement.

Document number: 1505905

Version: 05.00 | 04/08/2025 | en

Dear Customer,

Thank you for trusting our products and our family-owned company, the leading technology supplier of robots and production machines.

Our team is always available to answer any questions on this product and other solutions. Ask us questions and challenge us. We will find a solution!

Best regards,

Your SCHUNK team

Customer Management

Tel. +49-7133-103-2503

Fax +49-7133-103-2189

cmg@de.schunk.com



Please read the operating manual in full and keep it close to the product.

Table of Contents

1 General	4
1.1 About this manual.....	4
1.2 Target group	4
1.3 Symbol definition.....	4
1.4 Presentation of Warning Labels	5
1.5 Applicable documents	5
1.6 Brands.....	5
2 Description of function	6
3 Connecting the product to the robot control system	7
4 Installing the software module	9
4.1 Installation on the FlexPendant	9
4.2 Installation in RobotStudio.....	12
5 Uninstalling the software module	14
5.1 Uninstallation on the FlexPendant.....	14
5.2 Uninstallation in RobotStudio	14
6 Configuring and testing the software module.....	16
6.1 Configuring gripper or clamping force block	16
6.2 Testing functions.....	17
6.3 Teaching sensors.....	18
7 Tool Center Point (TCP)	19
8 Inserting the functions into the program code.....	20
8.1 Wizard command: Open Gripper	22
8.2 Wizard command: Close Gripper	22
8.3 Wizard command: Blow Off ON	22
8.4 Wizard command: Blow Off OFF	22
8.5 Wizard command: Blow Off OFF for time.....	22
9 Example program: Pick & Place application	23
10 Advanced operation	24
10.1 RAPID commands	24
10.1.1 SCHUNK_Gripper.....	24
10.1.2 TCP data for the grippers.....	24
10.2 Module specification.....	25
10.2.1 MTB SG.....	25
10.2.2 MTB DG	25
10.2.3 MTB KS	26

1 General

1.1 About this manual

This manual contains information on the SCHUNK software add-in for ABB robots and its use.

The add-in enables the simple integration and actuation of the following products in ABB applications:

- MTB Application Kit SG-JGP-P
- MTB Applikations-Kit DG-JGP-P
- MTB Application Kit KS-PGS3

This manual describes the software environment for an ABB robot.

Before installing, check whether a more recent version of the software module is available at [schunk.com/downloads-software](https://www.schunk.com/downloads-software).

NOTE: The illustrations in this manual are intended to provide a basic understanding and may deviate from the actual version.

In addition to these instructions, the documents listed under ▶ 1.5 [4 5] are applicable.

1.2 Target group

This manual is intended for robot integrators who have basic mechanical and electrical training skills and who are also familiar with elementary programming concepts.

Commissioning and troubleshooting may only be performed by qualified personnel with appropriate training.

The following knowledge is required:

- Basic knowledge of robotics
- Knowledge in handling ABB robots
- RAPID knowledge

Electrical installations may only be carried out by a suitably trained electrician.

1.3 Symbol definition

The following symbols are used in this manual:

■ Prerequisite for an action

1. Action 1

2. Action 2

⇒ Intermediate results

⇒ Final results

▶ 1.3 [4 4]: chapter number and [page number] in hyperlinks

1.4 Presentation of Warning Labels

To make risks clear, the following signal words and symbols are used for safety notes.



⚠ DANGER

Dangers for persons!

Non-observance will inevitably cause irreversible injury or death.



⚠ WARNING

Dangers for persons!

Non-observance can lead to irreversible injury and even death.



⚠ CAUTION

Dangers for persons!

Non-observance can cause minor injuries.

NOTICE

Material damage!

Information about avoiding material damage.

1.5 Applicable documents

- Assembly and operating manual for the product:
 - MTB application kit SG-JGP-P *
 - MTB application kit DG-JGP-P *
 - MTB application kit KS-PGS3 *
- Assembly and operating manual of the sensor MMS 22-PI2 *
- Operating manual for ABB robot

The documents labeled with an asterisk (*) can be downloaded from [schunk.com/downloads](https://www.schunk.com/downloads).

1.6 Brands

- ABB is a registered trademark of Asea Brown Boveri Ltd.
- RobotStudio is a registered trademark of Asea Brown Boveri Ltd.

2 Description of function

The following functions are provided and are used to control the gripper and clamping force block:

SCHUNK app

The SCHUNK app allows the configuration of up to 10 grippers. Both the DIO ports used and gripper parameters can be configured.

Commands

Open Gripper

The gripper is opened completely.

Close Gripper

The gripper is closed completely.

Blow Off On

Activates or deactivates the blow-off nozzle for grippers.

Blow Off on for x sec

Activates the blow-off nozzle for grippers for x seconds

3 Connecting the product to the robot control system

Before connecting or commissioning the product, read the operating manual of the robot and observe the instructions in this manual!



⚠ WARNING

Risk of injury due to unexpected movements!

If the power supply is switched on or residual energy remains in the system, components can move unexpectedly and cause serious injuries.

- Before starting any work on the product: Switch off the power supply and secure against restarting.
- Make sure, that no residual energy remains in the system.



⚠ CAUTION

Risk of injury from electric shock due to contact with live parts!

- Follow the operating manual for the robot.
- Before starting any work on the product: Switch off the energy supply and secure against re-connection.

NOTICE

Possible damage to product!

The product or the robot may get damaged if electrical cables are connected or disconnected during operation.

- Connect or disconnect electrical connections only when the device is switched off.

NOTE

Safety-relevant signals (e.g. emergency stop) must be wired externally, e.g. via safety relays, thus completely disconnecting the product from the power supply.

- Perform a risk assessment for the entire robotic application based on legal requirements to evaluate all safety-related aspects of the application.

- There is no power or compressed air supply on.
- Product is mounted on the robot. Compressed air hose and cable are connected to the product, see product assembly and operating manual.

1. Connect the wire strands of the M12 cable to the terminals of the control unit. For connection assignment, see the following table.
2. Connect logic and power supply.
 - ⇒ LED "Power" lights up green.

Pin	Wire strand	Signal	Robot interface	
			Register	Assignment
1	Brown	+24 VDC	Digital I/O power	24 V
2	Blue	GND	Digital I/O power	GND
3	White	Sensor Gripper A, Position 1	Digital inputs	D10
4	Green	Sensor Gripper A, Position 2	Digital inputs	D11
5	Pink	Sensor Gripper B, Position 1 *	Digital inputs	D12
6	Yellow	Sensor Gripper B, Position 2 *	Digital inputs	D13
7	Black	Teach function, Sensor Gripper A	Digital outputs	D04
8	Grey	Teach function, Sensor Gripper B *	Digital Outputs	D05
9	Red	Switching Gripper A	Digital Outputs	D01
		Switching clamping force block	Digital outputs	D07
10	Violet	Switching Gripper B *	Digital Outputs	D02
11	Grey/ Pink	Enable signal Gripper	Digital outputs	D00
		Clamping force block enable signal		D06
12	Red/ Blue	Switching blow-off nozzle	Digital outputs	D03

Tab.: Connection assignment MTB to ABB

* not relevant for single grippers

4 Installing the software module

There are two options for installing the software module:

- Installation on the FlexPendant handheld teaching unit, ▶ 4.1 [□ 9]. No PC is required for this.
- Installation using *RobotStudio* programming and simulation software from ABB, ▶ 4.2 [□ 12].

NOTE

SCHUNK recommends using the "EdgeHTML" browser engine, which is set as the default. Otherwise, display errors may occur.

4.1 Installation on the FlexPendant

NOTE

To install the software, SCHUNK recommends using a USB stick.

Preparing the USB stick

The USB stick must meet the following requirements:

- Formatted in FAT32 format
 - Designation of the removable drive: "SCHUNK"
1. Product is mounted and connected to the robot control system.
 1. Download the current version of the software module from schunk.com/downloads-software then copy it to the USB stick.
 2. Connect the USB stick to the FlexPendant.
 3. Select the "Control software" button.

Installing

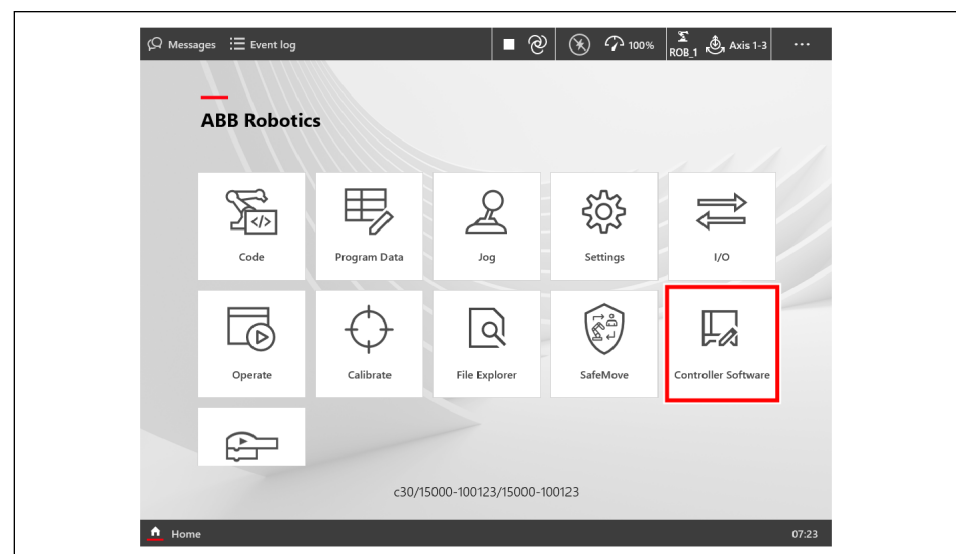

4. Select the "Add-In Installer" button.

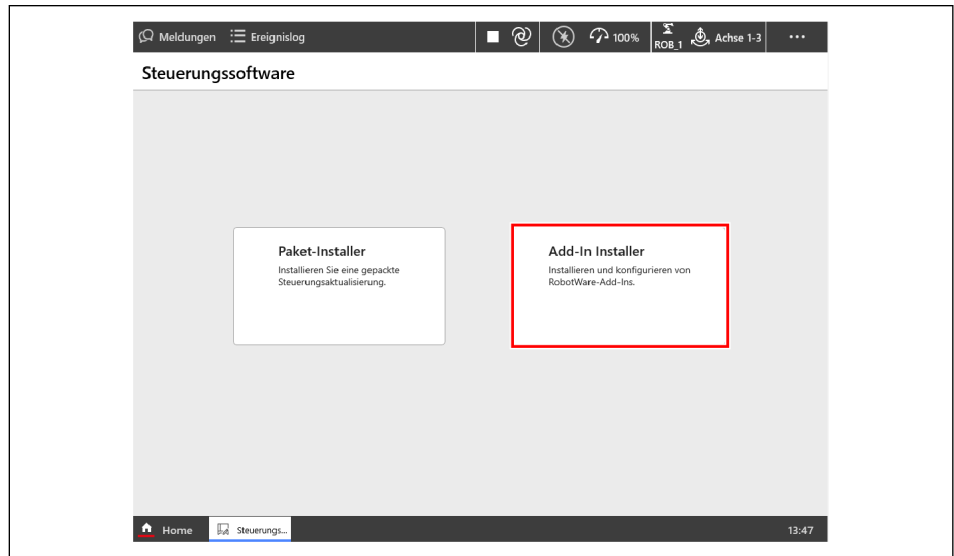

5. Select the "Add +Add-In" button.

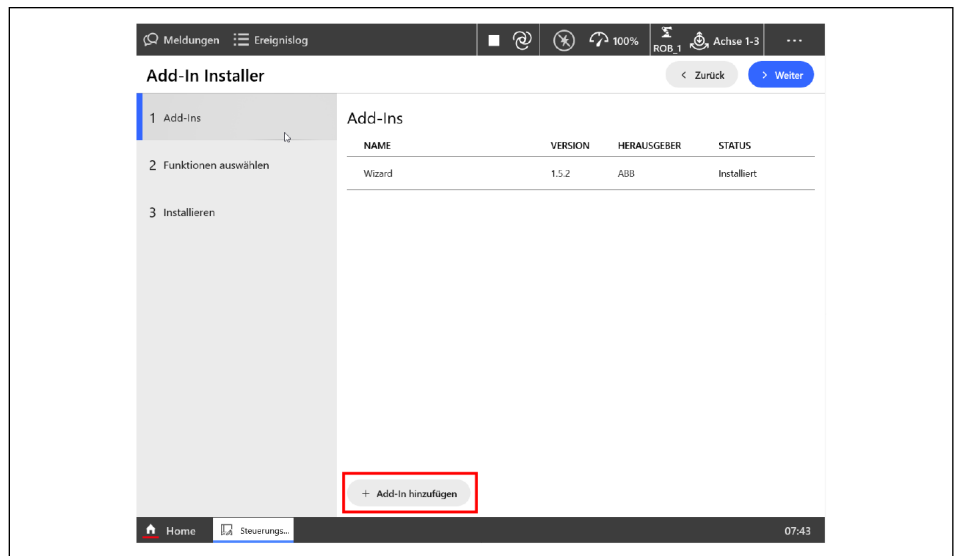

6. Select the "SCHUNK_IO_Gripper_x.x.x.rspa" software module and confirm by pressing "Select".

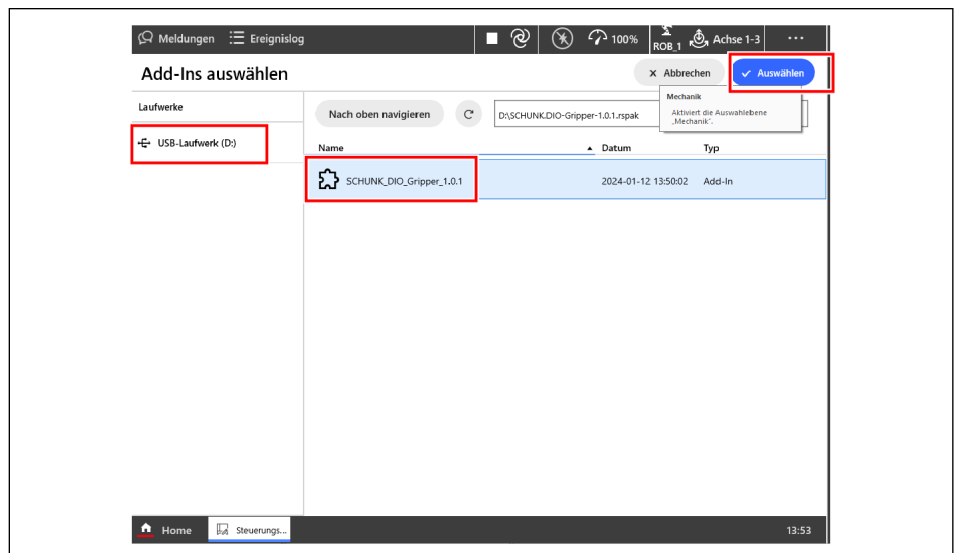

7. Under "Select functions" activate the "SCHUNK_IO_Gripper" checkbox.
8. Select the "> Next" button.

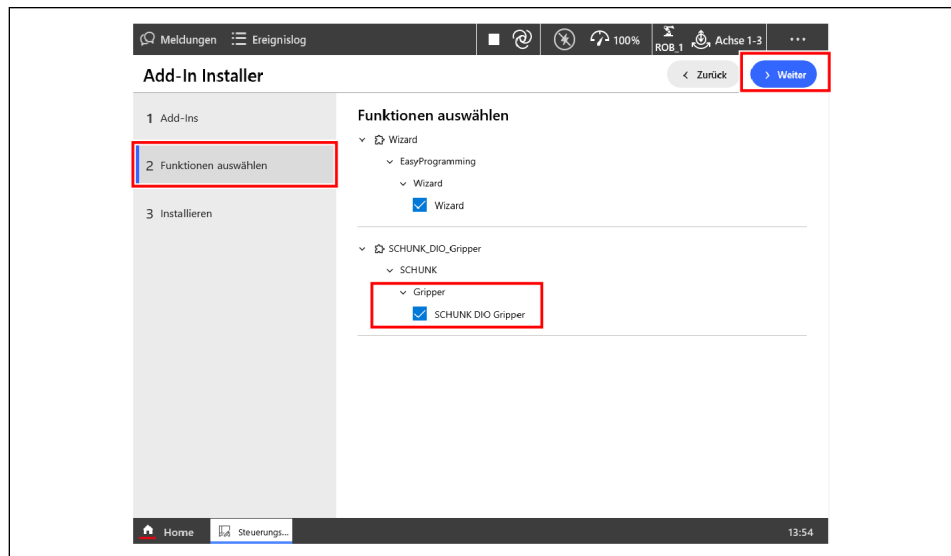

9. Select the "Apply" button.

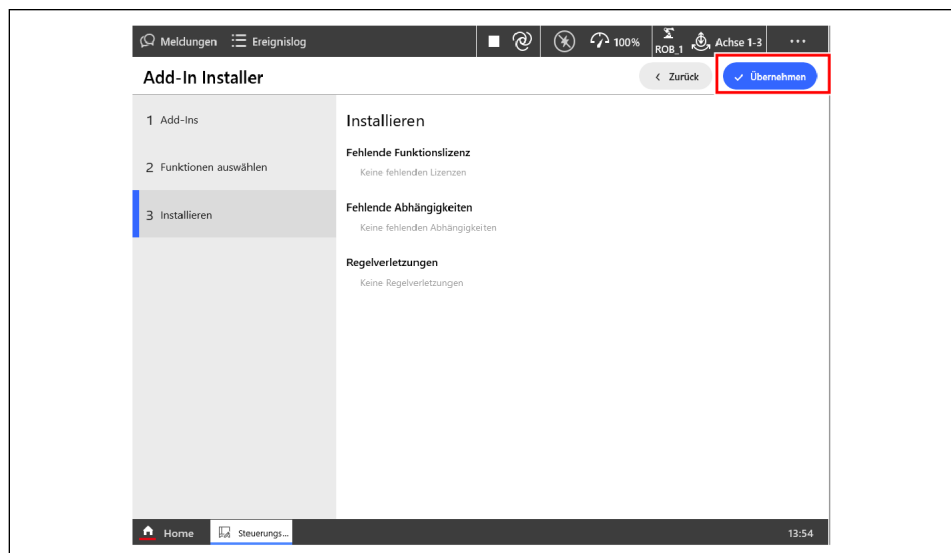

- ⇒ The software module is installed. This may take a few seconds.
- ⇒ The robot performs a restart.
- ⇒ Add-In has been installed.
- ⇒ A "SCHUNK IO" app appears on the FlexPendant under "Home".

4.2 Installation in RobotStudio

Installing

- Product is mounted and connected to the robot control system.
 - User PC and robot control system are connected to each other.
 - Programming and simulation software *RobotStudio* from ABB is installed on the PC.
1. Download the latest version of the software module at schunk.com/downloads-software and copy it into the directory of your choice.
 2. Start the control and *RobotStudio*.
 3. Select the tab "Add-Ins" > "Install Package" and select the current *.rspak file.
 4. Select the "Open" button.

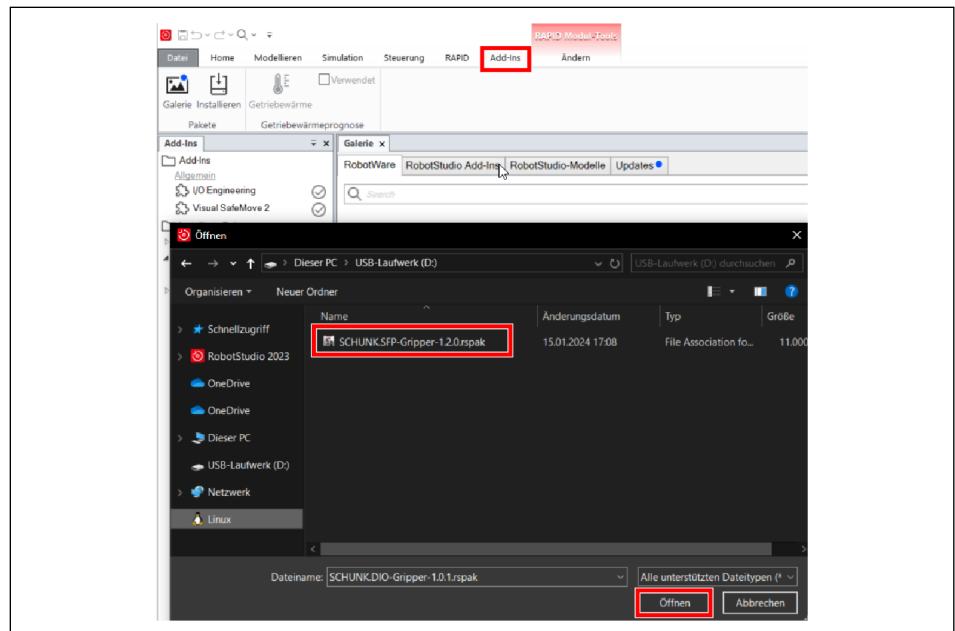

5. Select the "Control" > "Installation" > "Modify Installation" tab.

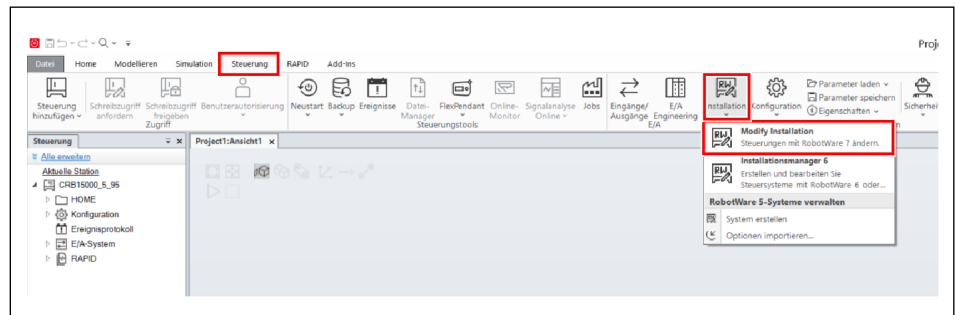

6. Adjust the configuration of the controller. Select the "Available" button.
7. Select the "Include" button for "SCHUNK_IO_Gripper" and confirm with "Apply".

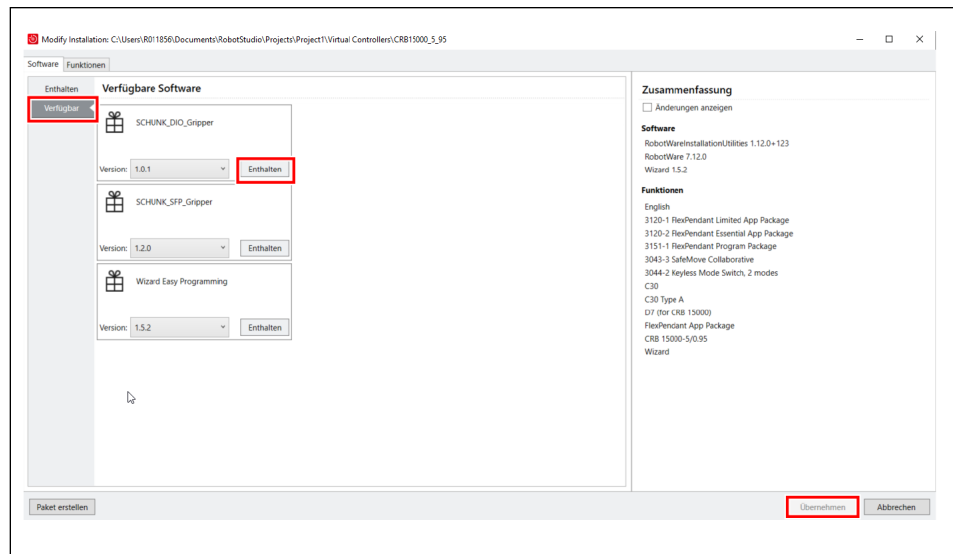

⇒ The software module has been installed.

8. Confirm the pop-up menu with "Yes".
- ⇒ The robot performs a restart.
- ⇒ A "SCHUNK IO" app appears on the FlexPendant under "Home".

5 Uninstalling the software module

There are two options for uninstalling the software module:

- Uninstallation on the FlexPendant handheld teaching unit, ▶ 5.1 [14]. No PC is required for this.
- Uninstallation using *RobotStudio* programming and simulation software from ABB, ▶ 5.2 [14].

5.1 Uninstallation on the FlexPendant

1. Select the "Control software" > "Add-In Installer" buttons.
2. Select the "SCHUNK_IO_Gripper_x.x.x.rspa" software module.
3. Select the "Remove add-In" and "Next" buttons.
 - ⇒ Robot performs a restart.
 - ⇒ Software module has been uninstalled and no longer appears as an app under "Home".

5.2 Uninstallation in RobotStudio

1. Select "Control" > "Installation" > "Modify Installation".
2. Select the "Remove" button for "SCHUNK_IO_Gripper".
3. Select the "Apply" button.

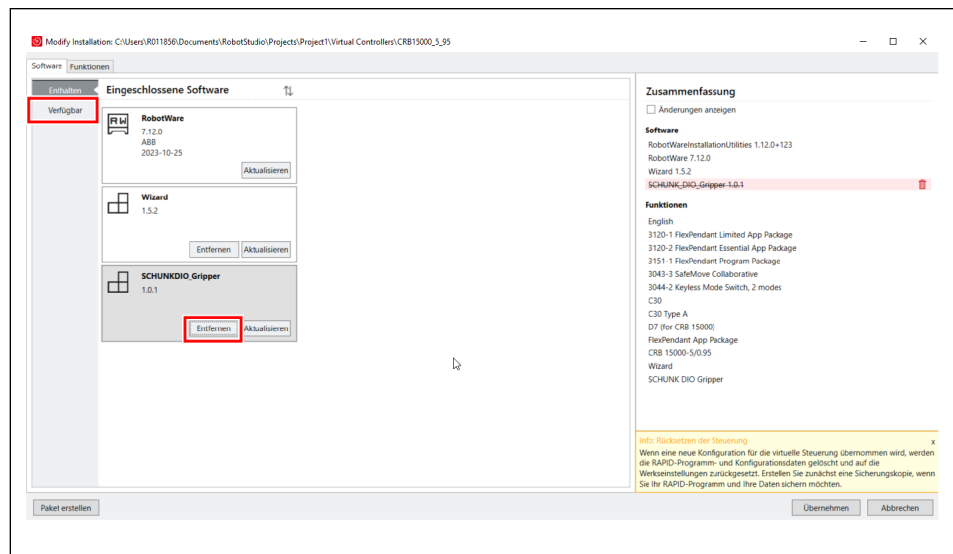

⇒ The software module has been uninstalled.

Further measures to remove all files from the robot:

- Delete the content on the robot at *HOME/WebApps/*.
- Delete all files on the robot at *HOME/BlockLibrary/*.
- Delete all controller signals with the name "MTB_DIO_x" under RobotStudio.
- Select "Reset Rapid and System Parameter" in RobotStudio.
Caution! All values and settings have been reset.

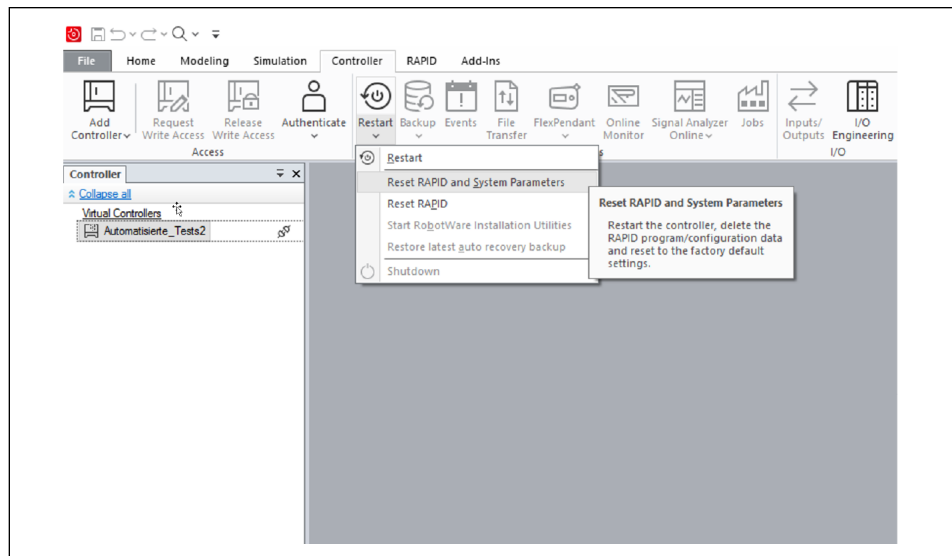
**Delivery state****Resetting the app to delivery state**

If it is necessary to reset the application to the delivery state, SCHUNK recommends the following procedure:

1. Delete the "cfg" file under *HOME/WebApps/SCHUNKWebApp*.
 2. Delete the "xgripperx.coblox" file under *HOME/BlockLibrary*.
- ⇒ The app has been reset to the delivery state.

6 Configuring and testing the software module

6.1 Configuring gripper or clamping force block

Basic configurations of the SCHUNK gripper can be made in the "SCHUNK IO" app.

- Selecting the implemented gripper
- Deleting and modifying configured grippers
- Wizard app is closed.

1. Select the "SCHUNK IO" app.

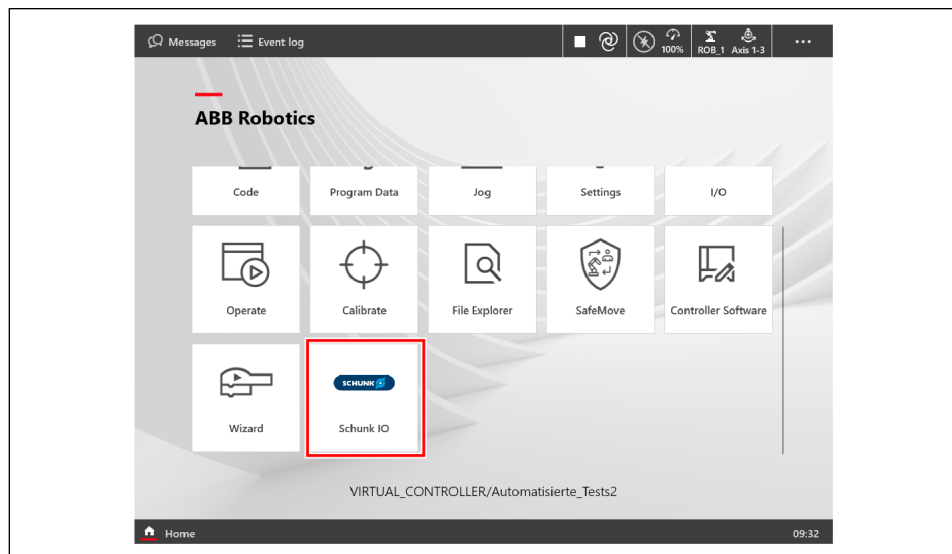

⇒ The SCHUNK start page opens.

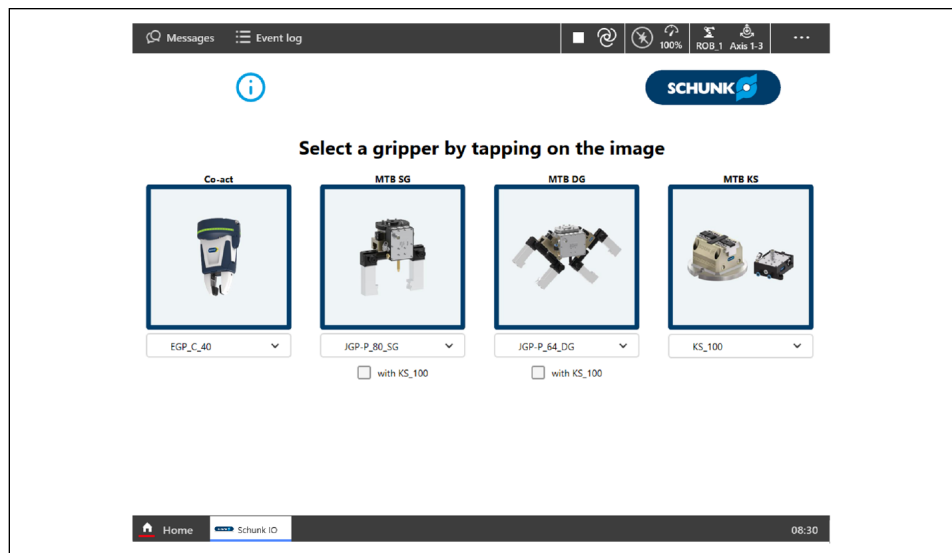

2. Select the connected gripper.

⇒ A walkthrough opens showing how to connect the gripper.

⇒ After completing the second to last page, the gripper is placed in the robot and restarted.

3. Start the "SCHUNK IO" app again.

⇒ The digital inputs and outputs of the gripper are displayed on the last page.

4. Select the "Next" button.

⇒ The test page opens to check the functionality of the gripper.

6.2 Testing functions

After restarting the control, the gripper functions and the correct wiring of the gripper can be checked.

Attention: The robot's motor must be switched on in order to be able to use the software module completely and correctly.

- The robot's motor is switched on.
- **CAUTION! Risk of injury! Moving parts. Components may move when testing the "Disable" function.** Select the respective button to test the function.

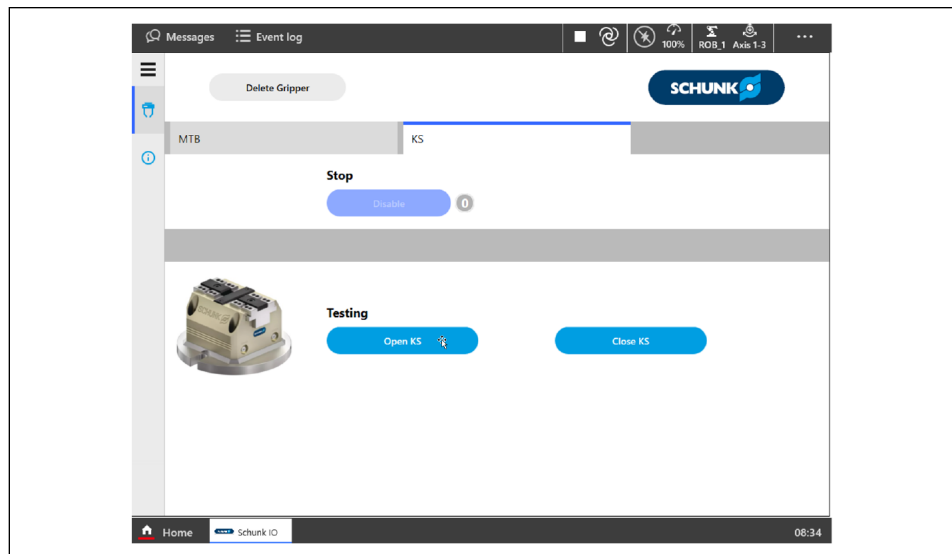
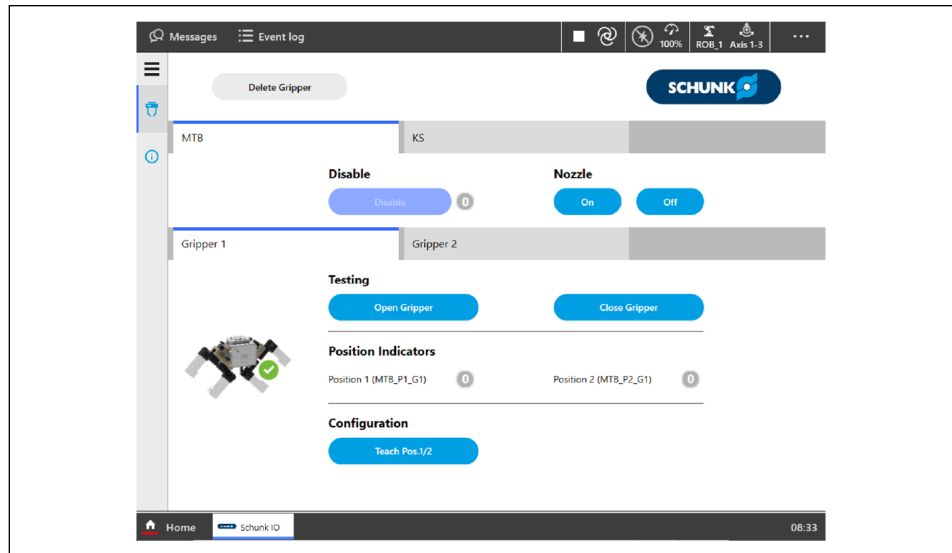

6.3 Teaching sensors

1. Move the base jaws to the desired position.
2. Select the "Configuration" > "Teach Pos. 1/2" buttons.
3. In the pop-up menu, select the sensor to be taught.
 - ⇒ The teach-in process is started and can take up to 30 seconds. The progress is shown in the progress bar at the bottom.

7 Tool Center Point (TCP)

For proper use of the product on an ABB robot, it is recommended to store the Tool Center Point (TCP), center of gravity and gripper weight in the robot settings.

TCP – Tool Center Point

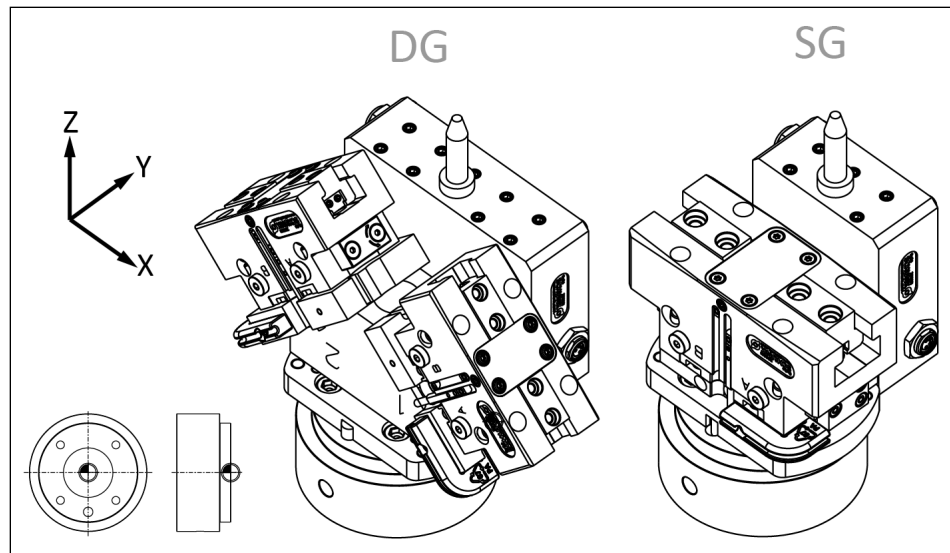

Tool Center Point, DG: double gripper, SG: single gripper

Size	TCP				Center of gravity			Weight [kg]
	X [mm]	Y [mm]	Z [mm]	RY [deg]	CX [mm]	CY [mm]	CZ [mm]	
MTB DG-JGP-P 64 *	62.6	0	68.5	±45	-0.5	12.8	44.5	1.73
MTB DG-JGP-P 80 *	69.7	0	75.5	±45	-0.5	15.3	37.6	2.21
MTB SG-JGP-P 80	0	0	65.5	-	-0.5	10	49.3	1.1
MTB SG-JGP-P 100	0	0	71.5	-	-0.5	11.4	40.9	1.49

* For the double gripper: Note the angle of 45° when calculating the TCP values.

NOTE

The blow-off nozzle may protrude beyond the TCP, creating an interference contour. For dimensions, see catalog data sheet at [schunk.com/downloads](https://www.schunk.com/downloads).

8 Inserting the functions into the program code

The Wizard app simplifies the programming procedure on ABB robots. The generated sequences are translated into RAPID code. To be able to use the tool data of a gripper, it must first be assigned to a variable of the type "tooldata".

NOTE

If the gripper configuration changes, the old configuration must be removed in the dashboard via the "Delete Grippers" button and a new configuration must be created by going through the walk-through again.

1. Select the "Wizard" button.

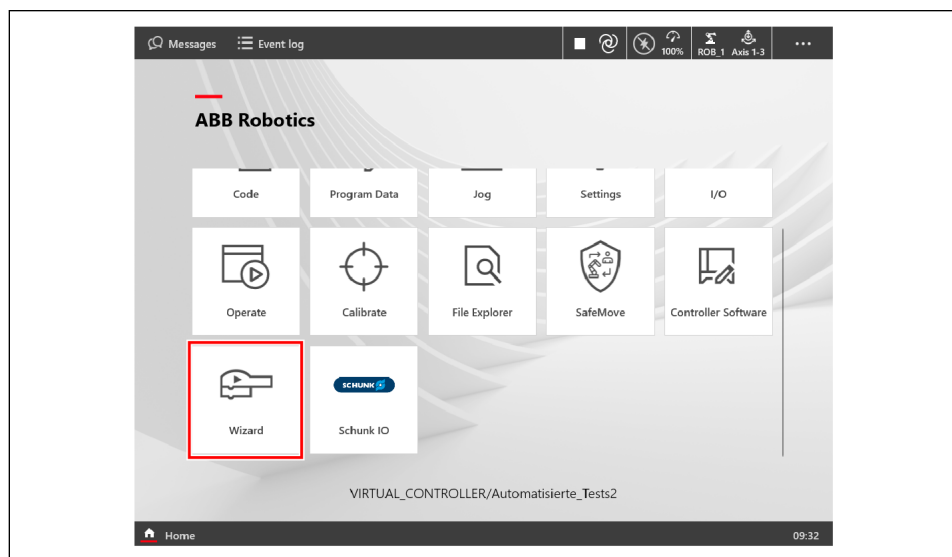

2. Open the "Code" app.
3. Open the "SCHUNK_IO_Gripper" file.

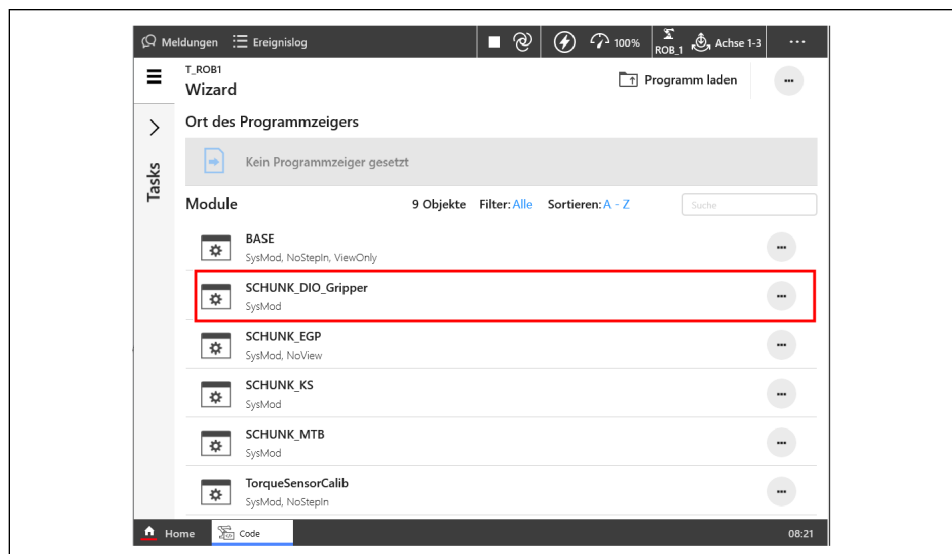

⇒ Tool data can be viewed in the Rapid files.

- ⇒ The three variables "DIO_grpParam..." contain the tool data for the configured grippers. The fingers have not yet been taken into account and must be added, ▶ 7 [19].

```

1 MODULE SCHUNK_DIO_Gripper(SYSMODULE)
2 ! (c) SCHUNK SE & Co. KG 2024
3 RECORD DIO_SCHUNK_gripperParam
4   string gripperName;
5   string group;
6   tooldata tool;
7   bool outerGrip;
8 ENDRECORD
9
10 PERS DIO_SCHUNK_gripperParam DIO_grpParam1 := ["JGP-P 64", "", [TRUE,
11 PERS DIO_SCHUNK_gripperParam DIO_grpParam2 := ["JGP-P 64", "", [TRUE
12 PERS DIO_SCHUNK_gripperParam DIO_grpParam3 := ["KS_100", "", [TRUE, [
13
14 ! only for compatibility
15 ! not needed in actual version
16 ! do not removed cause APP not working correct
17 PERS num DIO_actGrp;
18 ENDMODULE
19
20

```

4. Open the "Wizard" app.
5. Insert a "Custom code" command under "Script".
6. Select "Insert the Rapid" and insert lines for each gripper according to the following scheme: tooldata grippername = [TRUE,[[0,0,0],[1,0,0,0]],[0,[0,0,0],[1,0,0,0],0,0,0]]

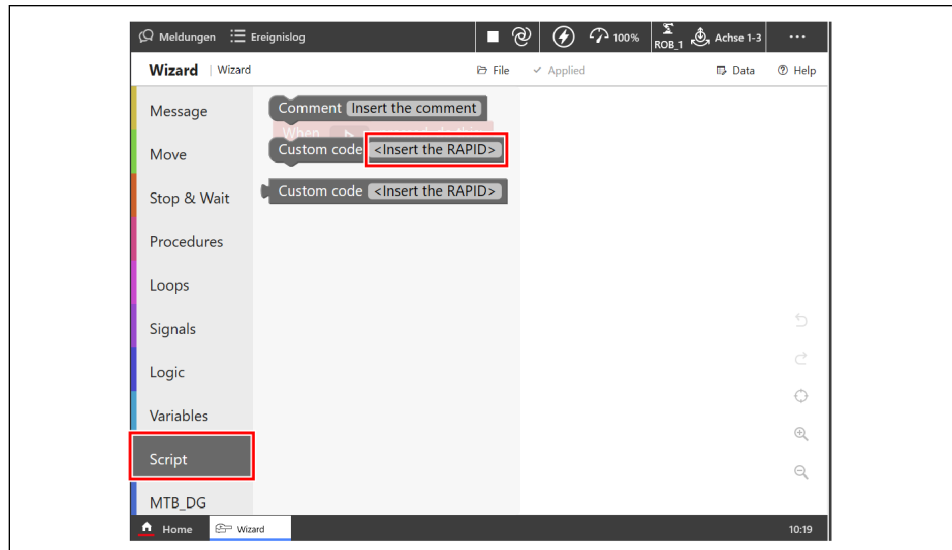

8.1 Wizard command: Open Gripper

The gripper is opened completely, i.e. the base jaws move to the maximum possible position.

8.2 Wizard command: Close Gripper

The gripper is closed completely, i.e. the base jaws move to the minimum possible position.

8.3 Wizard command: Blow Off ON

The blow-off nozzle is switched on.

8.4 Wizard command: Blow Off OFF

The blow-off nozzle is switched off.

8.5 Wizard command: Blow Off OFF for time

The blow-off nozzle is switched on for a certain time. This is specified in seconds [s]. After the time has elapsed, the blow-off nozzle is switched off.

9 Example program: Pick & Place application

This example shows the use of a gripper to pick up an object at a given position (*Picking_Position*) and place it at a second position (*Placing_Position*). If the gripping or placing fails, the robot should move to a safe position (*Safe_Position*).

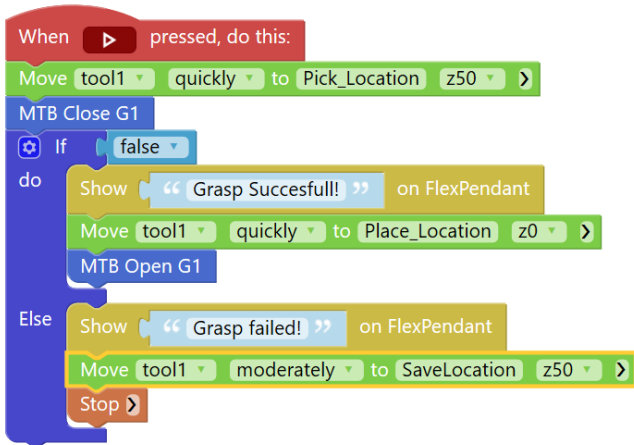

Pick Object with inner grip at Picking_Location

Robot moves to the previously taught position and tries to grip the workpiece there.

IF loop

Checks whether the gripper has reached its previously taught position and therefore gripped the object correctly.

If the digital input is MTB_P1_G1 -> HIGH, the object has been gripped successfully. The robot can move to the placing position to place the object.

If the digital input is 0 -> LOW, a "Grasp failed!" popup appears. The robot moves to a safe position and stops to wait for further user input.

Release object at Placing_Location

The robot moves to the previously defined position where the object is to be placed and executes the Release command there.

Move Gripper Tool to Save_Location

The robot moves to the safe position and waits for further input.

10 Advanced operation

The following knowledge/prerequisites are required for advanced operation:

- RAPID knowledge
- RobotStudio knowledge
- Familiarity with signal handling

10.1 RAPID commands

10.1.1 SCHUNK_Gripper

The SCHUNK_Gripper system module contains all of the commands used to activate a SCHUNK IO gripper:

- EGP_Open
- EGP_Close
- EGP_IsClose
- EGP_IsOpen
- KS_Stop
- KS_Open
- KS_Close
- MTB_Open_G1
- MTB_Close_G1
- MTB_MTB_IsPos1_G1
- MTB_MTB_IsPos2_G1
- MTB_Open_G2
- MTB_Close_G2
- MTB_MTB_IsPos1_G2
- MTB_MTB_IsPos2_G2
- MTB_Stop
- MTB_Nozzle_OnTime(\num time)
- MTB_Nozzle_Off
- MTB_Nozzle_On

10.1.2 TCP data for the grippers

This data can be changed in RAPID if

- the TCP does not just move along the fingers or
- the gripper is not attached to the robot arm using the adapter plate supplied by SCHUNK.

10.2 Module specification

10.2.1 MTB SG

- Teachable sensors available
- In the delivery state, the sensors are set to completely open/closed.
- Blow-off nozzle available.

10.2.1.1 Signal functions

- ENABLE: Activation of the functions
- CONTROL_N: Actuation of blow-off nozzle
- CONTROL_1: Control of gripper 1
- TEACH_1: Teach input position sensor gripper 1

10.2.1.2 Tool data

MTB-SG-JGP-P-80:

```
["JGP-P_80","MTB_SG",[TRUE,[[0,0,65.5],[1,0,0,0]],[1.1,[-0.5,15.3,37.6],[1,0,0,0],0,0,0]],FALSE];
```

MTB-SG-JGP-P-100:

```
["JGP-P_100","MTB_SG",[TRUE,[[0,0,71.5],[1,0,0,0]],[1.49,[-0.5,11.4,40.9],[1,0,0,0],0,0,0]],FALSE];
```

10.2.2 MTB DG

- Teachable sensors available
- In the delivery state, the sensors are set to completely open/closed.
- Blow-off nozzle available.
- Two grippers on one mechanism
 - For gripper 1, the gripper instance is preceded by a "1".
 - For gripper 2, the gripper instance is preceded by a "2".
 - Rotation around the y-axis is included in the TCP calculations.

10.2.2.1 Signal functions

- ENABLE: Activation of the functions
- CONTROL_N: Actuation of blow-off nozzle
- CONTROL_1: Control of gripper 1
- CONTROL_2: Control of gripper 2
- TEACH_1: Teach input position sensor gripper 1
- TEACH_2: Teach input position sensor gripper 2
- P1_1: Position sensor 1 Gripper 1
- P1_2: Position sensor 1 Gripper 2
- P2_1: Position sensor 2 Gripper 1
- P2_2: Position sensor 2 Gripper 2

10.2.2.2 Tool data

$q1 := \text{Sqrt}(1 + 2 * \cos(45^\circ) + 1) / 2$

$q2 := \text{Sqrt}(1 - 2 * \cos(45^\circ) + 1) / 2$

mtbTool_q2{1} := q2

mtbTool_q2{2} := -q2

MTB-DG-JGP-P-64:

["JGP-P_64","MTB_DG",[TRUE,[[0,-62.6,68.5],[0.924,0.383,0,0]],
[1.73,-0.5,12.8,44.5],[1,0,0,0],0,0,0]],FALSE];

["JGP-P_64","",[TRUE,[[0,62.6,68.5],[0.924,-0.383,0,0]],
[1.73,-0.5,12.8,44.5],[1,0,0,0],0,0,0]],FALSE];

MTB-DG-JGP-P-80:

["JGP-P_80","MTB_DG",[TRUE,[[0,-69.7,75.5],[0.924,0.383,0,0]],
[2.21,-0.5,10,49.3],[1,0,0,0],0,0,0]],FALSE];

["JGP-P_80","",[TRUE,[[0,69.7,75.5],[0.924,-0.383,0,0]],
[2.21,-0.5,10,49.3],[1,0,0,0],0,0,0]],FALSE];

10.2.3 MTB KS

Note: This product line is not designed to be attached to a robot.

10.2.3.1 Signal functions

- ENABLE: Activation of the functions
- CONTROL_N: Actuation of blow-off nozzle





SCHUNK SE & Co. KG
Spanntechnik | Greiftechnik | Automatisierungstechnik

Bahnhofstr. 106 - 134
D-74348 Lauffen/Neckar
Tel. +49-7133-103-0
info@de.schunk.com
schunk.com

Folgen Sie uns | *Follow us*



Wir drucken nachhaltig | *We print sustainable*