

# Modular tool mounting device

## TOOLFIX

### Assembly and Operating Manual

Translation of Original Operating  
Manual

Hand in hand for tomorrow

## Imprint

### Copyright:

This manual is protected by copyright. The author is SCHUNK SE & Co. KG.  
All rights reserved.

### Technical changes:

We reserve the right to make alterations for the purpose of technical improvement.

**Document number:** 1510829

**Version:** 02.00 | 23/01/2025 | en

Dear Customer,

Thank you for trusting our products and our family-owned company, the leading technology supplier of robots and production machines.

Our team is always available to answer any questions on this product and other solutions. Ask us questions and challenge us. We will find a solution!

Best regards,

Your SCHUNK team

Customer Management

Tel. +49-7572-7614-1300

Fax +49-7572-7614-1039

cmm@de.schunk.com



**Please read the operating manual in full and keep it close to the product.**

## Table of Contents

<b>1 General</b> .....	<b>5</b>
1.1 About this manual.....	5
1.1.1 Illustration of warnings .....	5
1.1.2 Applicable documents .....	6
1.2 Warranty .....	6
1.3 Product Overview .....	6
<b>2 Basic safety notes</b> .....	<b>7</b>
2.1 Appropriate use .....	7
2.2 Inappropriate use .....	7
2.3 Structural changes.....	7
2.4 Spare parts .....	7
2.5 Ambient conditions and operating conditions .....	8
2.6 Personnel qualifications .....	8
2.7 Personal protective equipment .....	9
2.8 Notes on safe operation.....	9
2.9 Transport.....	10
2.10 Malfunctions .....	10
2.11 Disposal .....	10
2.12 Fundamental dangers .....	10
2.12.1 Protection during handling and assembly .....	11
2.12.2 Protection during commissioning and operation .....	11
2.12.3 Notes on particular risks .....	11
<b>3 Technical data</b> .....	<b>13</b>
3.1 Maximum load values .....	13
<b>4 Assembly</b> .....	<b>16</b>
4.1 Screw tightening torques .....	16
4.2 Pre-assembly measures .....	16
4.3 Mounting .....	17
<b>5 Description of function</b> .....	<b>18</b>
5.1 TOOLFIX MONO basic module .....	18
5.2 TOOLFIX VARIO basic module .....	19
5.3 TOOLFIX MONO tool adapter .....	19
5.4 TOOLFIX VARIO tool adapter .....	20
5.5 TOOLFIX TURN tool adapter .....	20
5.6 Various locking mechanisms .....	21
5.6.1 Spring latch .....	21
5.6.2 Screw lever .....	21
5.6.3 Screw .....	22

<b>6 Operation</b> .....	<b>23</b>
<b>7 Maintenance and care</b> .....	<b>24</b>
7.1 TOOLFIX MONO basic module .....	24
7.2 TOOLFIX VARIO basic module .....	25
7.3 TOOLFIX MONO or VARIO tool adapter – ISO ( SK/BTCat ) / HSK ( A+B ) / VDI .....	27
7.4 TOOLFIX MONO or VARIO tool adapter – HSK (E+F) .....	28
7.5 TOOLFIX MONO or VARIO tool adapter – Capto .....	29
7.6 TOOLFIX TURN tool adapter .....	30
<b>8 Storage</b> .....	<b>31</b>

# 1 General

## 1.1 About this manual

This manual contains important information for the safe, correct use of the product.

It is an integral part of the product and must be kept accessible for personnel at all times.

Personnel must have read and understood this manual before beginning any work. The observance of all safety notes in this manual is a prerequisite to ensure safe work processes.

The illustrations are intended to provide a basic understanding and may deviate from the actual version.

Besides this manual, other documents which apply are those listed under ▶ 1.1.2 [ 6 ]

### 1.1.1 Illustration of warnings

To make risks clear, the following signal words and symbols are used for safety notes.



#### **⚠ DANGER**

Denotes a hazard with a high degree of risk that, if not avoided, will result in death or serious injury.



#### **⚠ WARNING**

Denotes a hazard with a medium degree of risk that, if not avoided, could result in death or serious injury.



#### **⚠ CAUTION**

Denotes a hazard with a low degree of risk that, if not avoided, could result in a minor or moderate injury.

#### **CAUTION**

Information about avoiding material damage.

### 1.1.2 Applicable documents

- General Terms and Conditions \*
- Catalog data for the purchased product
- Product approval drawing

The documents labeled with an asterisk (\*) can be viewed and/or downloaded at [www.schunk.com](http://www.schunk.com).

### 1.2 Warranty

The warranty is valid for 24 months from the date of delivery from the production facility.

Parts touching the workpiece and wearing parts are not covered by the warranty.

### 1.3 Product Overview

#### TOOLFIX tool mounting devices

- Basic modules for mounting the system at the workplace
  - TOOLFIX MONO → with permanently mounted tool adapter
  - TOOLFIX VARIO → with quick-change function for tool adapter
- Tool adapters for basic modules in all common sizes ( ISO / SK / BT / Cat / VDI / HSK / CAPTO)
  - MONO system → tool adapters are permanently mounted on the basic module
  - VARIO system → tool adapters can be inserted into the VARIO basic module via quick-change function
  - TURN system → tool adapters for MONO and VARIO system with additional turning function around the tool axis including detent positions

## 2 Basic safety notes

### 2.1 Appropriate use

The TOOLFIX system series is intended for installing toolholder mountings for cutting machines at industrial workplaces for the purpose of maintenance or service work on the toolholder mounting or changing the tool or indexable cutter inserts clamped in the mounting.

- The products may only be used within the scope of their technical application
- The products are intended for industrial applications.
- Appropriate use of the product includes compliance with all instructions in this manual.

### 2.2 Inappropriate use

TOOLFIX tool mounting devices are being used inappropriately, for example, if:

- they are used as a clamping device, toolholder, load-handling device or as lifting equipment.
- toolholder tapers are fixed for the purpose of machining.
- they are used in working environments that are not permissible.
- the technical data specified by the manufacturer are exceeded during usage.

### 2.3 Structural changes

#### Implementation of structural changes

Modifications, changes or reworking, e.g. additional threads, holes, or safety devices, can damage the product or impair its functionality or safety.

- Structural changes may only be implemented with the written approval of SCHUNK.

### 2.4 Spare parts

#### Use of unauthorized spare parts

Using unauthorized spare parts can endanger personnel and damage the product or cause it to malfunction.

- Only use original spare parts and spares authorized by SCHUNK.

## 2.5 Ambient conditions and operating conditions

### Required ambient conditions and operating conditions

Incorrect ambient and operating conditions can make the product unsafe, leading to the risk of serious injuries, considerable material damage and/or a significant reduction in the product's life span.

- Make sure that the product is only used within its defined application parameters.
- Ensure that the product is of a sufficient size for the workpiece.
- Ensure that the insertion surfaces of the tool adapters are always clean. Always ensure that no chips of any kind enter the insertion surfaces.

## 2.6 Personnel qualifications

Any work on the product by inadequately qualified personnel can lead to serious injuries and considerable material damage.

- All work must only be performed by appropriately qualified personnel.
- Personnel must have read and understood the complete manual before beginning any work on the product.
- Observe country-specific accident prevention regulations and the general safety notes.

The following personnel qualifications are required for the various activities on the product:

### Specialist personnel:

Specialist personnel have the specialized training, knowledge, and experience to perform the tasks entrusted to them, to recognize and avoid potential dangers, and know the relevant standards and regulations.

### Instructed person:

Instructed persons have been instructed by the operator regarding the tasks entrusted to them and the potential dangers of inappropriate behavior.

### Manufacturer's service personnel:

The manufacturer's service personnel have the specialized training, knowledge, and experience to perform the work entrusted to them and to recognize and avoid potential dangers.

## 2.7 Personal protective equipment

### Use of personal protective equipment

Personal protective equipment serves to protect staff against danger which may interfere with their health or safety at work.

- When working on and with the product, observe the occupational health and safety regulations and wear the required personal protective equipment.
- Observe the valid safety and accident prevention regulations.
- Wear protective gloves to guard against sharp edges and corners and rough surfaces.

## 2.8 Notes on safe operation

### Incorrect manner of working by personnel

An incorrect manner of working can make the product unsafe and risks serious injuries and considerable material damage.

- Only toolholder mountings suitable for the tool adapter may be clamped.
- Modified or damaged toolholder mountings must not be clamped with the TOOLFIX adapters.
- Do not use a hammer to loosen any stuck screws on clamped toolholder mountings.
- Avoid any manner of working that may interfere with the function and operational safety of the product.
- Use the product as intended.
- Observe the safety notes and assembly instructions.
- Do not expose the product to any corrosive media.
- Rectify malfunctions as soon as they occur.
- Observe the care and maintenance instructions.
- Observe the current safety, accident prevention, and environmental protection regulations for the application field of the product.

### Maintenance specifications

Follow the maintenance and care instructions. These instructions relate to a normal industrial environment. If the product is to be operated in an environment with abrasive dusts or corrosive or aggressive fumes or fluids, prior approval must be obtained from SCHUNK.

### Safety during assembly and servicing

During assembly, connection, adjustment, commissioning and testing, make sure that no accidental operation of the system by the installation technician or other persons is possible.

## 2.9 Transport

### Handling during transport

Incorrect handling during transport can make the product unsafe and risks serious injuries and considerable material damage.

- When handling heavy weights, use lifting equipment to lift the product and transport it by appropriate means.
- During transport and handling, secure the product to prevent it from falling.
- Do not walk under suspended loads.

## 2.10 Malfunctions

### Behavior in case of malfunctions

- Immediately remove the product from operation and report the malfunction to the responsible departments/persons.
- Order appropriately trained personnel to rectify the malfunction.
- Do not recommission the product until the malfunction has been rectified.
- Test the product after a malfunction to establish whether it still functions properly and ensure no further risks have arisen.

## 2.11 Disposal

### Handling during disposal

Incorrect handling during disposal can make the product unsafe and risks serious injuries and considerable material and environmental harm.

- Follow local regulations on dispatching product components for recycling or proper disposal.

## 2.12 Fundamental dangers

### General

- Observe safety distances.
- Never deactivate safety installations.

### 2.12.1 Protection during handling and assembly

#### Incorrect handling and assembly

Incorrect handling and assembly can make the product unsafe and risk serious injuries or considerable material damage.

- All work must only be performed by appropriately qualified personnel.
- For all work, secure the product against accidental operation.
- Observe the relevant accident prevention regulations.
- Use suitable assembly and transport equipment and take precautions to prevent jamming and crushing.

#### Incorrect lifting of loads

Falling loads can cause serious injuries and even death.

- Stand clear of suspended loads and do not step within their swiveling range.
- Never move loads without supervision.
- Do not leave suspended loads unattended.

### 2.12.2 Protection during commissioning and operation

#### Falling components

Falling tools and toolholders can lead to serious injury or death.

- Take suitable protective measures to secure the danger zone.
- Wear suitable protective equipment.

### 2.12.3 Notes on particular risks



#### **⚠ WARNING**

**Risk of injury from tools or toolholder tapers falling out when using the TOOLFIX mounting systems.**

Parts that have not been properly secured can come loose and fall out.

- Ensure that the locking mechanism of the tool adapter is correctly engaged and that the toolholder mounting is correctly seated.
- Ensure that only suitable toolholder mountings are clamped in the tool adapters.
- Wear personal protective equipment.



### **⚠ WARNING**

**Risk of injury to the operating personnel during transport and assembly of the TOOLFIX mounting system.**

- Use a crane or a transport truck when transporting.
- Wear personal protective equipment.



### **⚠ WARNING**

**Risk of injury from sharp cutting edges. There is a fundamental risk of injury when working with machining tools.**

- When working with machining tools in TOOLFIX mounting systems, special care is required when standing within direct reach of the free-standing tool in the TOOLFIX component.
- Wear personal protective equipment.
- Make sure that no other person besides the operator is within reach of the fixed tool.



### **⚠ CAUTION**

**There is a risk of limbs being crushed by moving parts during manual loading and unloading and the clamping procedure.**

- Do not reach into the toolholder mounting.
- Use loading devices.
- Wear protective gloves.

### 3 Technical data

Installation position      Mount basic modules in the vertical axis

Operating temperature      +5°C to +60°C

#### Basic modules

Type	Quick change	Suitable adapters
TOOLFIX MONO	No	MONO and TURN
TOOLFIX VARIO	Yes	VARIO and TURN

#### Tool adapter

Type	Quick change	Rotatable around the tool axis
MONO tool adapter	No	No
VARIO tool adapter	Yes	No
TURN tool adapter	Yes	Yes

All TOOLFIX tool adapters are available ex works in the following sizes:

**ISO (SK, BT):** 20, 25, 30, 35, 40, 45, 50 & 60

**VDI:** 16, 20, 25, 30, 40, 50, 60 & 80

**HSK (Form A-F):** 32, 40, 50, 63, 80, 100, 125

**Capto:** C3, C4, C5, C6, C8 & C10

Further sizes are available on request.

#### 3.1 Maximum load values

For the following calculation values, it should be noted that hammer blows and impulses are not taken into account.

Maximum load TOOLFIX MONO basic module:



**Maximum load TOOLFIX VARIO basic module:**

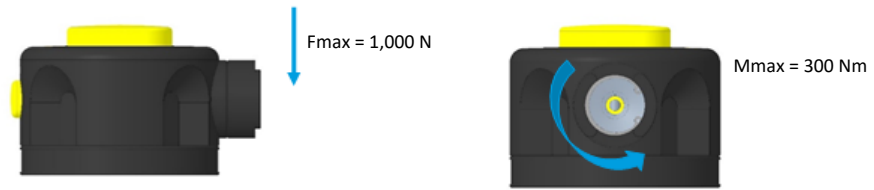

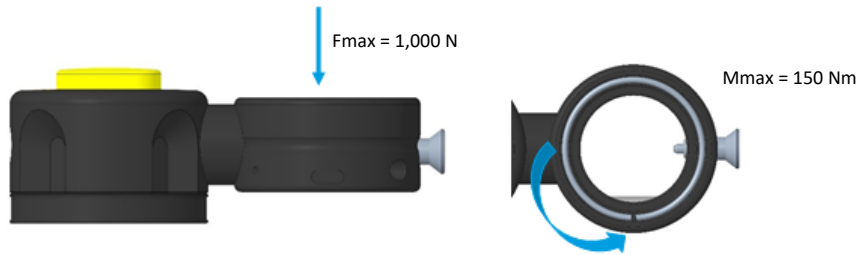

**Maximum load TOOLFIX TURN basic module:**

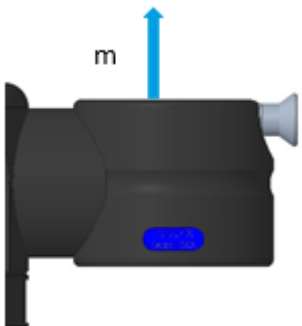

**Maximum load of the tool adapter:**

Tool adapter type	Size	Maximum loading weight m	Permissible torque M
	32	3.5 kg	150 Nm
	40	7 kg	150 Nm
	50	7 kg	300 Nm
	63	7 kg	300 Nm
	80	7 kg	300 Nm
	100	6 kg	300 Nm
	125	8 kg	300 Nm
	30	5 kg	100 Nm
	35	6 kg	120 Nm
	40	6 kg	120 Nm
	45	6 kg	200 Nm
	50	6 kg	300 Nm
	60	7 kg	300 Nm
	20	5 kg	80 Nm
	25	4 kg	80 Nm
	30	4 kg	200 Nm
	40	4.5 kg	250 Nm
	50	4.5 kg	300 Nm

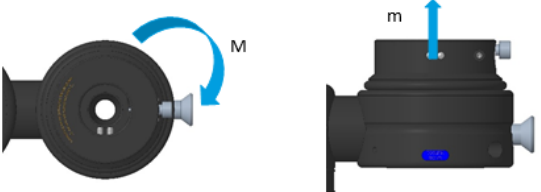
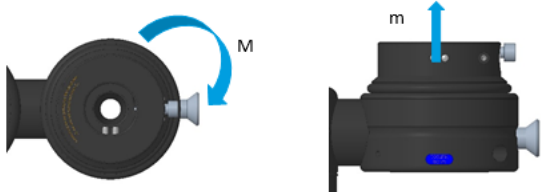
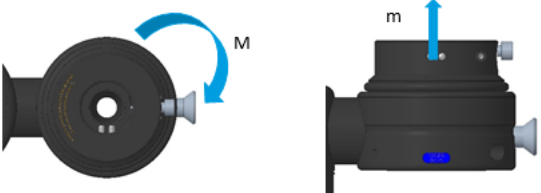
Tool adapter type	Size	Maximum loading weight m	Permissible torque M
CAPTO 	C3	50 kg	-
	C4	100 kg	-
	C5	100 kg	-
	C6	100 kg	-
	C8	100 kg	-
KM 	40	100 kg	200 Nm
	50	100 kg	100 Nm
ISO TURN 	30	100 kg	150 Nm
	40	100 kg	150 Nm
	50	100 kg	150 Nm
	60	5 kg	150 Nm
HSK-A Turn 	40	100 kg	150 Nm
	63	6.5 kg	100 Nm
	80	6.5 kg	150 Nm
	100	7 kg	150 Nm
	125	100 kg	150 Nm
Capto Turn 	C4	100 kg	150 Nm
	C6	100 kg	150 Nm
	C8	100 kg	150 Nm

## 4 Assembly

### 4.1 Screw tightening torques

Screw tightening torques for fastening TOOLFIX MONO and VARIO basic modules to the workstation (screw quality 10.9).

Screw size	M10	M12
Maximum admissible torques $M_A$ [Nm]	69	121

### 4.2 Pre-assembly measures



#### **⚠ CAUTION**

**Risk of injury due to sharp edges and rough or slippery surfaces.**

- Wear personal protective equipment, particularly protective gloves.

Check that the delivery is complete and that there is no transport damage. Assembly, dismantling and modification work on the products may only be carried out by specialist personnel.

When selecting the location for mounting the TOOLFIX system, ensure there is suitable and ergonomic accessibility and take heed of the ambient conditions. Mounting the TOOLFIX system is only permitted on firmly anchored work tables or cabinets. Slippery or uneven surfaces in front of the mounted system must be avoided to enable the employee to stand as safely as possible.

The mounting surface for the TOOLFIX basic module should be level and free of chips and other contamination.

If the TOOLFIX basic module is to be screwed on from above, four M10 threads of sufficient depth must be produced in a 90 mm x 90 mm  $\pm 0.1$  arrangement.

If the TOOLFIX basic module is to be screwed on from below, four  $\varnothing 13$  holes must be drilled through. If the screw heads are countersunk due to sinks, care must be taken to ensure that the countersinks are made in accordance with the standards.

### 4.3 Mounting



#### ⚠ WARNING

**Risk of injury to the operating personnel during transport and assembly of the TOOLFIX components**

- Use a crane or a transport truck when transporting.
- Wear personal protective equipment.

During installation, observe the correct tightening torques of the mounting screws as well as a sufficient screw-in depth.

Below is an example of M10 mounting from above ① and an example of M12 mounting from below ②.

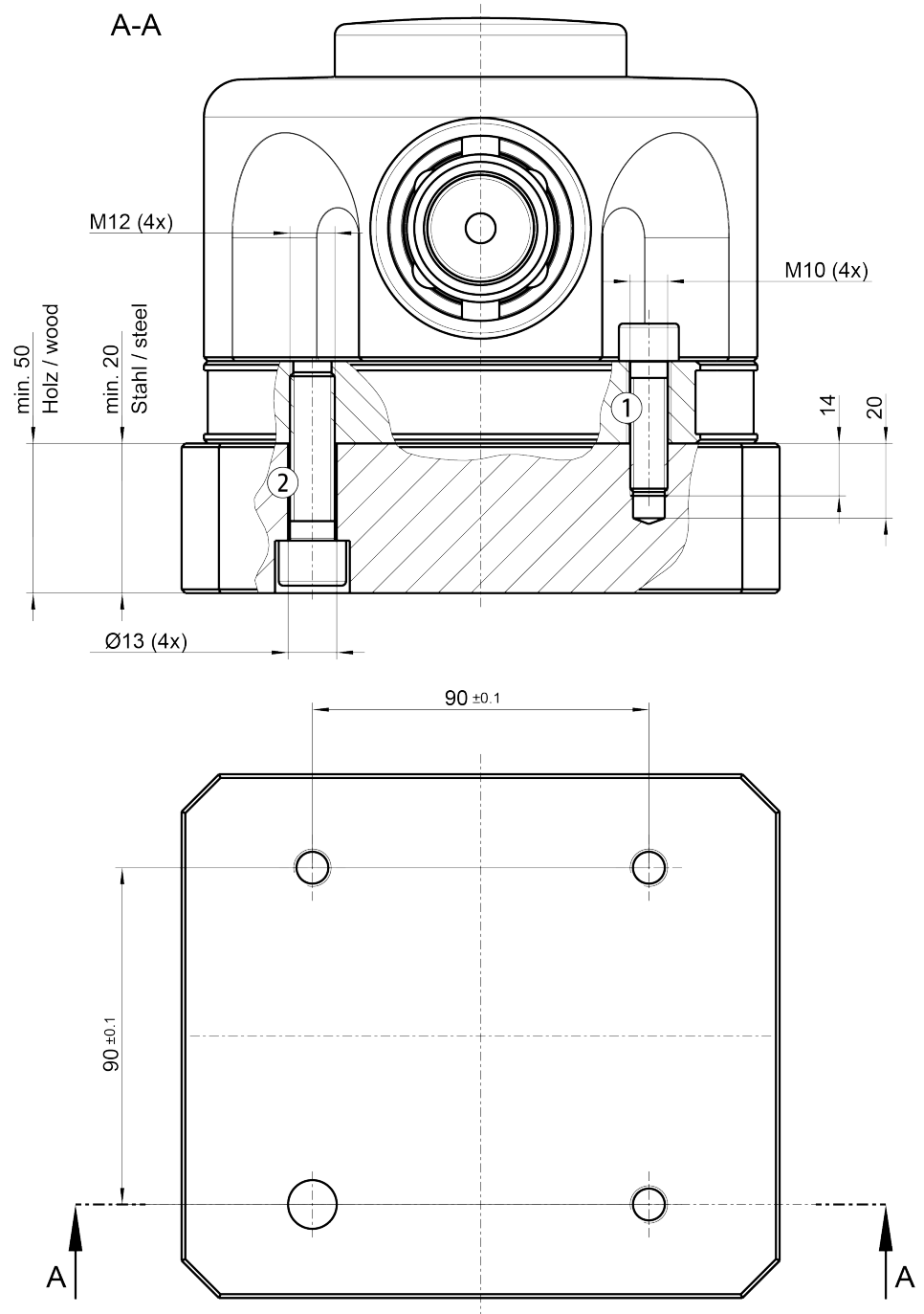

## 5 Description of function

TOOLFIX products enable the quick fixing of toolholder tapers for the servicing, maintenance and replacement of tools and indexable cutter inserts. The VARIO product series also allows for the flexible quick-change of various tool adapters.

The TURN product series (available in MONO and VARIO versions) allows the clamped tool to be rotated around its own axis and locked in various rotational positions to achieve optimum tool accessibility.

Before working on clamped tools / toolholder mountings, check locking of the tool adapter.

### 5.1 TOOLFIX MONO basic module

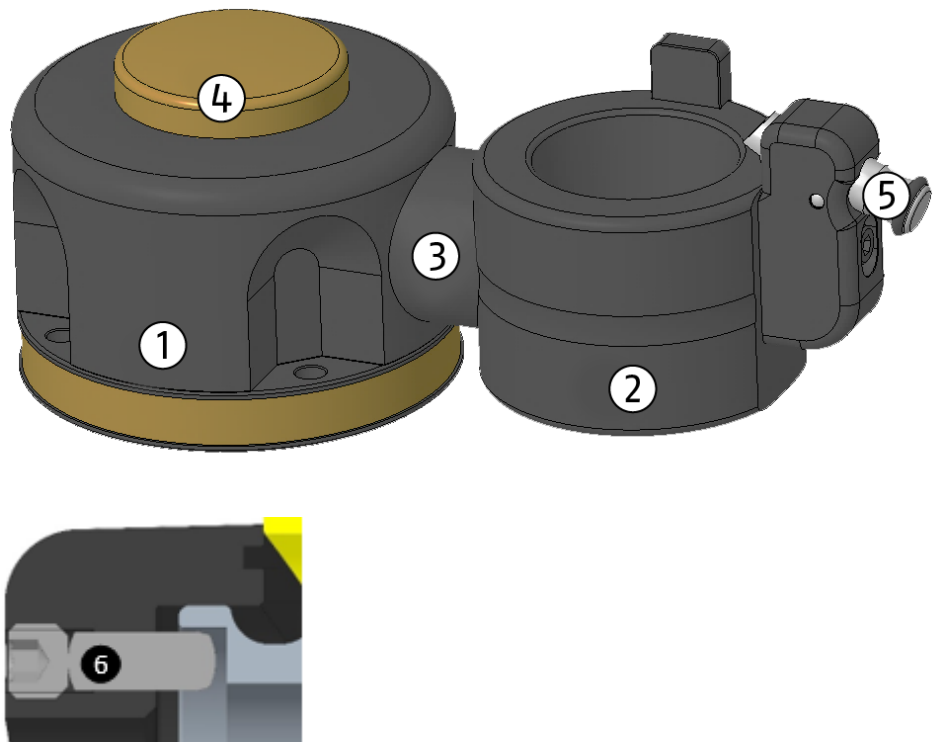

The TOOLFIX MONO basic module ① is firmly connected to the associated tool adapter ② via the connecting shaft ③. Pressing the top release mechanism ④ releases a lock and the tool adapter ② can now be rotated 180° around the middle axis of the connecting shaft ③. The cylindrical pin ⑥ on the back of the basic module prevents it from rotating 360°. Removing the cylindrical pin ⑥ is not permitted. When the release mechanism ④ is released, the tool adapter ② snaps back into place at one of 4 possible detent positions.

## 5.2 TOOLFIX VARIO basic module

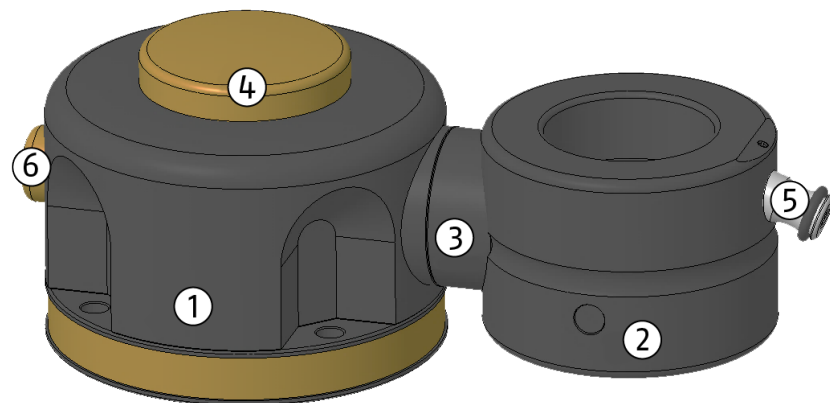

The TOOLFIX VARIO basic module ① enables the associated tool adapters ② to be changed quickly by actuating the release mechanism ⑥. If the release mechanism ⑥ is pressed, the tool adapter ② with connecting shaft ③ can be pulled out of the basic module ① to the right.

Pressing the top release mechanism ④ releases a lock and the tool adapter ② can now be rotated freely around the middle axis of the connecting shaft ③.

When the release mechanism ④ is released, the tool adapter ② snaps back into place at one of 8 possible detent positions.

## 5.3 TOOLFIX MONO tool adapter

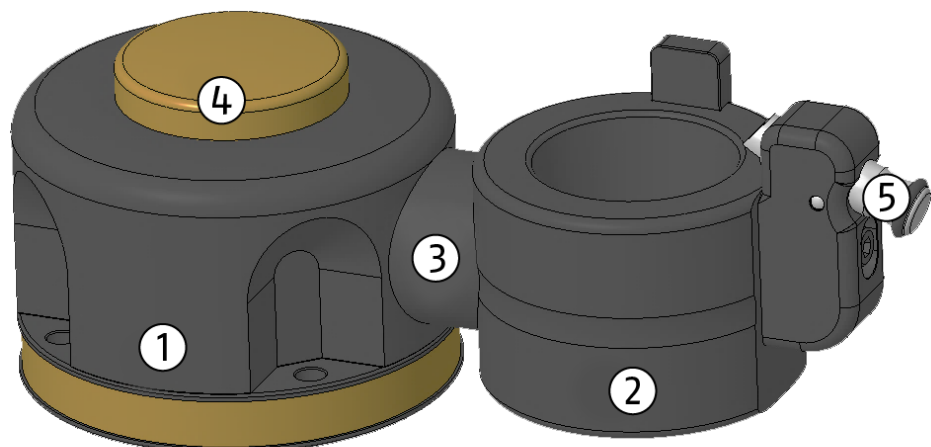

The TOOLFIX MONO tool adapter ② is compatible with the TOOLFIX MONO basic body and is firmly connected to it ① via the connecting shaft ③. After equipping the tool adapter with a toolholder mounting, secure it against falling out by locking the locking mechanism ⑤. Depending on the design of the tool adapter, different locking mechanisms are implemented. Before loading and unloading the tool adapter, bring the axis of the toolholder mounting of the tool adapter ② into vertical position. The opening of the clamped toolholder taper protrudes upwards.

## 5.4 TOOLFIX VARIO tool adapter

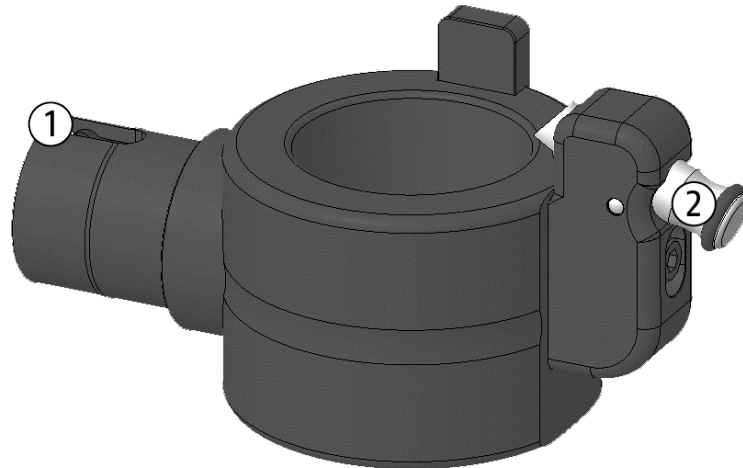

The TOOLFIX VARIO tool adapter is compatible with the TOOLFIX VARIO basic module. The quick-change interface ① allows a quick and easy change between different tool adapters in the basic module. After equipping the tool adapter with a toolholder mounting, secure it against falling out by locking the locking mechanism ②. Depending on the design of the tool adapter, different locking mechanisms are implemented. Before loading and unloading the tool adapter, bring the axis of the toolholder mounting in the tool adapter ② into vertical position. The opening of the clamped toolholder taper protrudes upwards.

## 5.5 TOOLFIX TURN tool adapter



The TOOLFIX TURN tool adapter is compatible with the TOOLFIX VARIO basic module or the TOOLFIX MONO basic module (depending on which version is available). After equipping the tool adapter with a toolholder mounting, secure it against falling out by locking the locking mechanism ②. Before loading and unloading the tool adapter, bring the axis of the toolholder mounting in the tool adapter ② into vertical position. The opening of the clamped toolholder taper protrudes upwards. The TOOLFIX TURN tool adapter also allows clamped toolholder mountings to be rotated around their own axis to ensure optimum accessibility to all desired positions. This turning function is released

when the spring latch ③ is pulled outwards. The clamped toolholder mounting can now be rotated around its own axis until the spring latch ③ engages again at the next detent position.

## 5.6 Various locking mechanisms

### 5.6.1 Spring latch

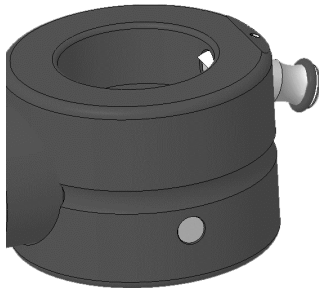

Fig. 1: ISO/VDI/HSK (A+B)

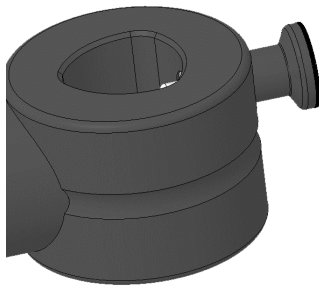
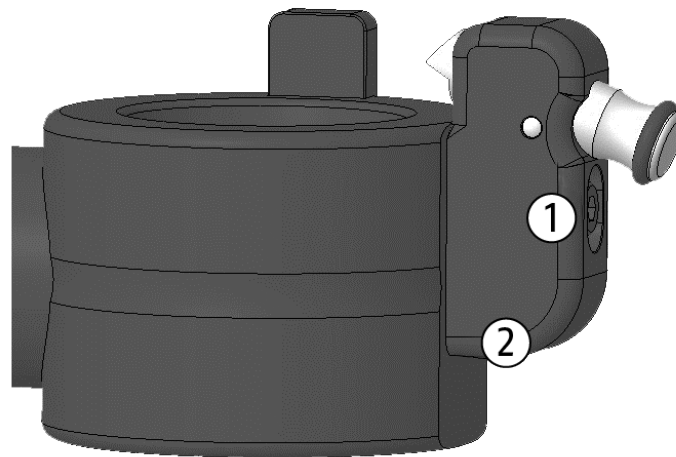

Fig. 2: Capto



On the TOOLFIX VARIO or MONO tool adapter of the ISO version, the spring latch is positioned on the tool adapter via a cylindrical clamp. The height of the cylindrical clamp is adjustable. For this, the clamping screw ① must first be loosened with a hexagon socket wrench SW6 in order to be able to adjust the height of the complete cylindrical clamp via the adjusting screw ② with a hexagon socket wrench SW4. The height of the cylindrical clamp must be adjusted so that the spring latch rests on the flank of the groove or on the edge of the toolholder taper.

### 5.6.2 Screw lever

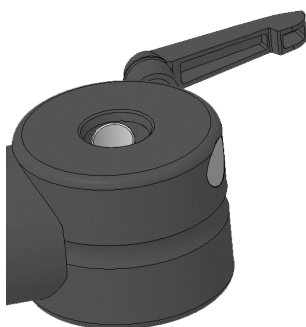

Fig. 3: HSK (E+F)

The TOOLFIX MONO and VARIO tool adapters in the HSK (E+F) version are clamped by actuating a screw lever. When the screw lever is turned clockwise, two clamping fingers move tangentially towards the toolholder mounting. When these reach their maximum end position, the toolholder taper is securely clamped. The toolholder mounting is released again by turning the screw lever counterclockwise.

### 5.6.3 Screw

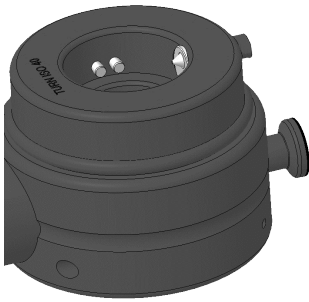

Fig. 4: TOOLFIX TURN

The TOOLFIX MONO and VARIO tool adapters in the TURN version are clamped by screwing in a locking screw. Turning the screw clockwise locks the toolholder taper in the tool adapter. The toolholder mounting is released again by turning the screw counterclockwise.



The height of the locking screw for the flat work surface of the tool adapter is adjustable and must be set so that the cone at the threaded end of the screw engages in the groove of the toolholder taper. To adjust the height of the locking screw, the clamping screw ② must first be loosened with a hexagon socket wrench SW3. Now the eccentric nut ① can be turned until the locking screw is at the desired height. After the adjustment, the clamping screw ② must be tightened again.

## 6 Operation



### ⚠ WARNING

**Risk of injury from tools or toolholder tapers falling out when using the TOOLFIX mounting system.**

Parts that have not been properly secured can come loose and fall down.

- Ensure that the locking mechanism of the tool adapter is correctly engaged and that the toolholder mounting is correctly seated.
- Ensure that only suitable toolholder mountings are clamped in the tool adapters.
- Wear personal protective equipment.



### ⚠ WARNING

**Risk of injury to the operating personnel during transport and assembly of the TOOLFIX mounting system.**

- Use a crane or a transport truck when transporting.
- Wear personal protective equipment.



### ⚠ WARNING

**Risk of injury from sharp cutting edges. There is a fundamental risk of injury when working with machining tools.**

- When working with machining tools in TOOLFIX components, special care is required when standing within direct reach of the free-standing tool in the TOOLFIX component.
- Wear personal protective equipment.
- Make sure that no other person besides the operator is within reach of the fixed tool.



### ⚠ CAUTION

**There is a risk of limbs being crushed by moving parts during manual loading and unloading and the clamping procedure.**

- Do not reach into the toolholder mounting.
- Use loading devices.
- Wear protective gloves.



5. The tool adapter ② must still be rotatable and the release mechanism must remain engaged.
6. Now continue to turn the tool adapter ② clockwise until, at a total rotation of approx. 45°, the release mechanism ④ snaps back up.
7. The tool adapter ② must now no longer be rotatable in any direction.
8. Now repeat steps 3 – 7 and check the grid positions at the total rotations -90°, -45°, 0°, 45° and 90°.

## 7.2 TOOLFIX VARIO basic module

**Monthly: Visual and functional inspection and cleaning of the quick-change interface for tool adapters:**

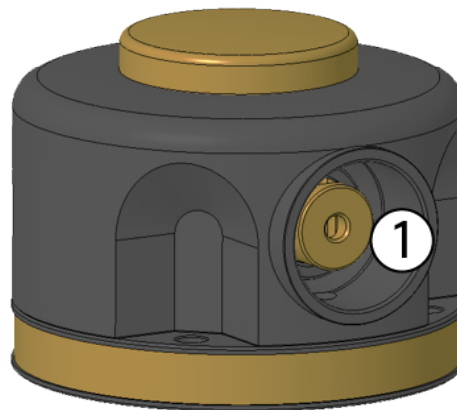

1. Remove the engaged tool adapter from the quick-change interface ①.
2. Clean the interface and visually inspect it for damage or increased signs of wear.
3. Actuate the release mechanism several times and observe the quick-change interface ①. When the release mechanism is actuated, a selector shaft in the center of the quick-change interface ① moves in and out axially.
4. Measure the axial stroke of the selector shaft. Set value: 4.7 mm  $\pm$  0.3 mm
5. Now insert a tool adapter into the quick-change interface ① without actuating the release mechanism. Slide the tool adapter into the basic module up to the stop and measure the distance shown. Nominal dimension: 12.5 mm.

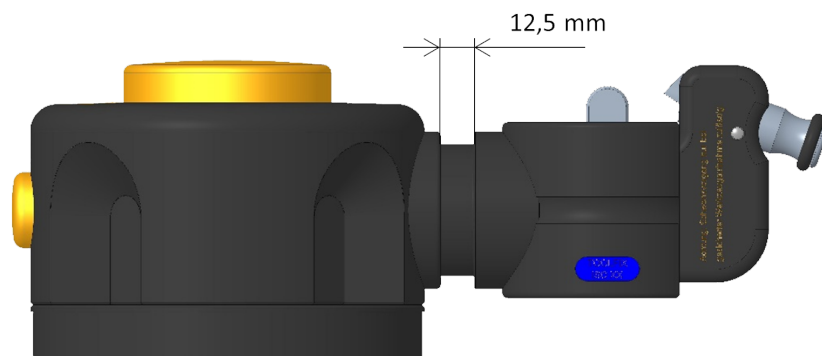

6. Activate the release mechanism and slide the tool adapter 2 – 3 mm further.
7. Take the pressure off the release mechanism.
8. The push button for the release mechanism remains engaged.
9. Now slide the tool adapter into the basic module up to the stop. When the end position is reached, the push button of the release mechanism disengages again. The tool adapter can now no longer be removed.

**Monthly: Functional test 45° detent and rotary function tool adapter:**

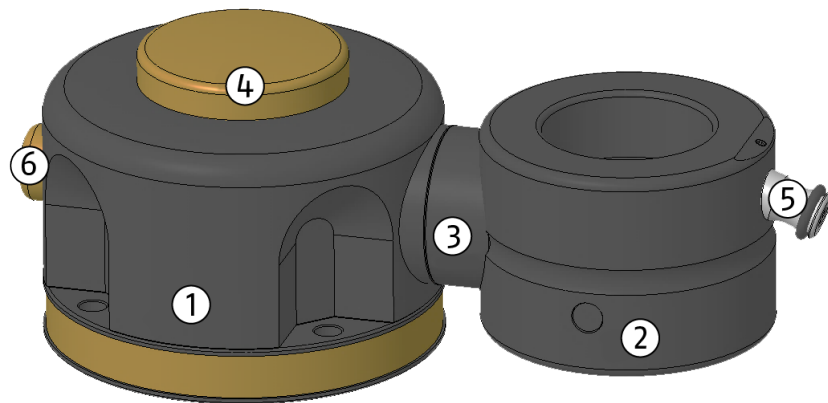

1. If there is a toolholder mounting in the tool adapter ②, remove it.
2. Turn and lock the tool adapter ② to create a vertical axis alignment with the toolholder mounting, the exposed side of which is at the top. (See graphic above).
3. Press the release mechanism ④ down and turn the tool adapter ② approx. 5 – 10° clockwise around the middle axis of the connecting shaft ③.
4. Take the pressure off the release mechanism ④.
5. The tool adapter ② must still be rotatable and the release mechanism must remain engaged.
6. Now continue to turn the tool adapter ② clockwise until, at a total rotation of approx. 45°, the release mechanism ④ snaps back up.
7. The tool adapter ② must now no longer be rotatable in any direction.
8. Now repeat steps 3 – 7 and check the grid positions at the total rotations 0° – 45° – 90° – 135° – 180° – 225° – 270° – 315°.

### 7.3 TOOLFIX MONO or VARIO tool adapter – ISO ( SK/BTCat ) / HSK ( A+B ) / VDI



#### **Monthly: Visual inspection and cleaning of the quick-change interface ①**

Clean and inspect the quick-change interface ① of the tool adapter. In case of damage or heavy wear, the interface must be replaced (only necessary for adapters of the VARIO series).

#### **Monthly: Cleaning and visual inspection of the toolholder mounting interface ②**

Clean and inspect the toolholder mounting interface and associated alignment elements. In case of damage or heavy wear, the components must be replaced.

#### **Monthly: Functional check of the tool locking mechanism ③**

To check the function, pull the tool locking mechanism ③ several times to the rear and front end positions and release it. It must be possible to pull the pin completely out of the toolholder mounting interface ②. After releasing, the pin must snap automatically to the inner end position and must not rebound from this position. The pin must remain axially free from play in the inner end position. It must be possible to pull the pin with two fingers (smoothly).

#### **Monthly: Functional check of the torque pin**

Perform a test clamping to ensure that the torque pins at the lower end of the shaft engage securely in the toolholder mounting.

## 7.4 TOOLFIX MONO or VARIO tool adapter – HSK (E+F)

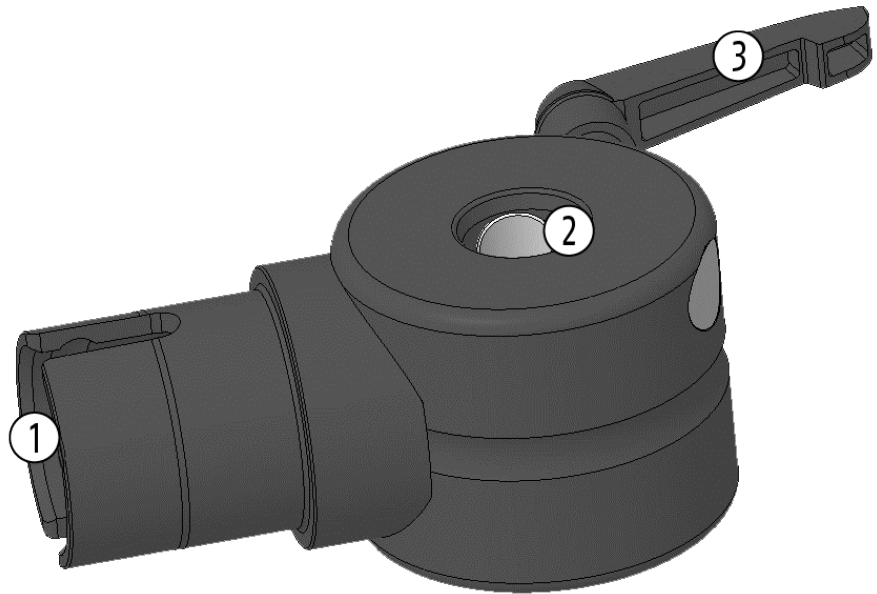

### **Monthly: Visual inspection and cleaning of the quick-change interface ①**

Clean and inspect the quick-change interface ① of the tool adapter. In case of damage or heavy wear, the interface must be replaced (only necessary for adapters of the VARIO series).

### **Monthly: Cleaning and visual inspection of the toolholder mounting interface ②**

Clean and inspect the toolholder mounting interface. In case of damage or heavy wear, the tool adapter must be replaced.

### **Monthly: Functional check of the tool locking mechanism ③**

Turn the tool locking mechanism counterclockwise until the two internal chuck jaws are completely retracted into the base body of the tool adapter. Then turn the locking mechanism clockwise until the jaws have moved to the inner end position. The hand lever of the locking mechanism must move smoothly during the complete clamping stroke. Perform a test clamping with an HSK form E or F toolholder.

## 7.5 TOOLFIX MONO or VARIO tool adapter – Capto

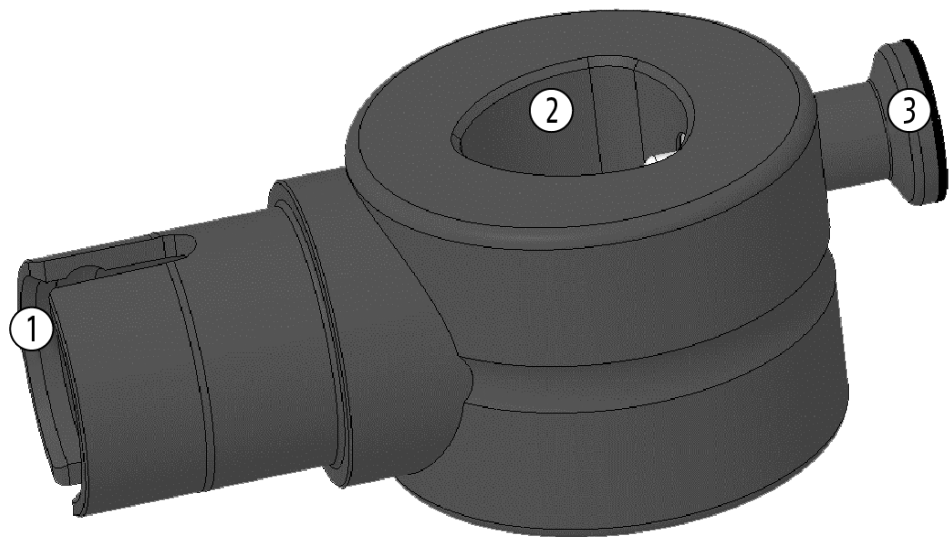

### Monthly: Visual inspection and cleaning of the quick-change interface ①

Clean and inspect the quick-change interface ① of the tool adapter. In case of damage or heavy wear, the interface must be replaced (only necessary for adapters of the VARIO series).

**Monthly: Cleaning and visual inspection of the toolholder mounting interface ②** Clean and inspect the toolholder mounting interface. In case of damage or heavy wear, the tool adapter must be replaced.

### Monthly: Functional check of the tool locking mechanism ③

Make sure that the tool locking mechanism ③ is completely screwed in. To do this, turn it clockwise and tighten it. To check the function, pull the tool locking mechanism ③ several times to the rear and front end positions and release it. It must be possible to pull the pin completely out of the toolholder mounting interface ②. After releasing, the pin must snap automatically to the inner end position and must not rebound from this position. The pin must remain axially free from play in the inner end position. It must be possible to pull the pin with two fingers (easily).

## 7.6 TOOLFIX TURN tool adapter



### **Monthly: Visual inspection and cleaning of the quick-change interface ①**

Clean and inspect the quick-change interface ① of the tool adapter. In case of damage or heavy wear, the interface must be replaced (only necessary for adapters of the VARIO series).

### **Monthly: Cleaning and visual inspection of the toolholder mounting interface ②**

Clean and inspect the toolholder mounting interface and associated alignment elements. In case of damage or heavy wear, the tool adapter must be replaced.

### **Monthly: Functional check of the tool locking mechanism ②**

Turn the screw of the locking mechanism ② completely out of the thread and clean the external thread of the screw and the nut thread. Visually inspect the cone at the front end of the screw. If the cone or the thread on the screw or nut thread is damaged, the corresponding parts must be replaced.

### **Monthly: Functional test 30° detent and rotary function toolholder taper:**

1. If there is a toolholder mounting in the tool adapter ②, remove it.
2. Turn the toolholder mounting until the tool locking mechanism ② comes to rest directly over the spring latch for the rotary lock ③.
3. Pull the spring latch for the rotary lock ③ outward and continue to turn the toolholder mounting 5° - 10° clockwise in the tool adapter.
4. Release the spring latch for the rotary lock ③ again.
5. The toolholder taper can still be rotated. Continue turning the toolholder taper until a total rotation of approx. 30° is reached. The spring latch must snap in and the rotation is locked.
6. Now repeat steps 3 - 5 and check the grid positions at the total rotations 0° - 30° - 60° - 90° - 120° - 150° - 180° - 210° - 240° - 270° - 300° - 330° - 360°.

### **Monthly: Functional check of the torque pin**

Perform a test clamping to ensure that the torque pins on the inside of the tool shank engage securely in the toolholder mounting.

## 8 Storage

When storing the product for a longer period of time, observe the following points:

- Clean the product and lubricate it lightly.
- Store the product in a suitable transport container.
- Only store the product in dry rooms.
- Protect the product from major temperature fluctuations.

**NOTE:** Before recommissioning, clean the product and all attachments, check for damage, functionality and leaks.



H.-D. SCHUNK GmbH & Co.  
Spanntechnik KG

Lothringer Str. 23  
D-88512 Mengen  
Tel. +49-7572-7614-0  
info@de.schunk.com  
schunk.com

Folgen Sie uns | *Follow us*



Wir drucken nachhaltig | *We print sustainable*