



# Assembly and Operating Manual

## SWS

### Quick-Change System

Translation of the original manual

## Imprint

### Copyright:

This manual is protected by copyright. The author is SCHUNK SE & Co. KG.  
All rights reserved.

### Technical changes:

We reserve the right to make alterations for the purpose of technical improvement.

**Document number:** 389456

**Version:** 15.00 | 22/04/2025 | en

Dear Customer,

Thank you for trusting our products and our family-owned company, the leading technology supplier of robots and production machines.

Our team is always available to answer any questions on this product and other solutions. Ask us questions and challenge us. We will find a solution!

Best regards,

Your SCHUNK team

Customer Management

Tel. +49-7133-103-2503

Fax +49-7133-103-2189

cmg@de.schunk.com



**Please read the operating manual in full and keep it close to the product.**

## Table of Contents

<b>1</b>	<b>General</b>	<b>7</b>
1.1	About this manual	7
1.1.1	Presentation of Warning Labels	7
1.1.2	Definition of Terms	7
1.1.3	Applicable documents	8
1.2	Warranty	8
1.3	Scope of delivery	8
1.4	Accessories	8
1.4.1	Seal kit	9
<b>2</b>	<b>Basic safety notes</b>	<b>10</b>
2.1	Intended use	10
2.2	Not intended use	10
2.3	Constructional changes	11
2.4	Spare parts	11
2.5	Ambient conditions and operating conditions	11
2.6	Personnel qualification	11
2.7	Personal protective equipment	12
2.8	Notes on safe operation	12
2.9	Transport	13
2.10	Malfunctions	13
2.11	Disposal	13
2.12	Fundamental dangers	13
2.12.1	Protection during handling and assembly	14
2.12.2	Protection during commissioning and operation	14
2.12.3	Protection against dangerous movements	14
2.13	Notes on particular risks	15
<b>3</b>	<b>Technical data</b>	<b>16</b>
3.1	Basic data	16
3.2	Ambient conditions and operating conditions	17
3.3	Max. permissible offset when mounting the SWA with end effector	17
<b>4</b>	<b>Design and description</b>	<b>19</b>
4.1	Description	19
4.1.1	Functional principle	19
4.2	Design	21
4.2.1	SWS 001	21
4.2.2	SWS 005	22
4.2.3	SWS 007	23
4.2.4	SWS 011	24

4.2.5	SWS 011HM .....	25
4.2.6	SWS 020 / 021 / 041 / 060 .....	26
4.2.7	SWS 020HM / 021HM.....	27
4.2.8	SWS 022.....	28
4.2.9	SWS 029 .....	29
4.2.10	SWS 040Q / 071 .....	30
4.2.11	SWS 046 .....	31
4.2.12	SWS 076 / 110 / 160 .....	32
<b>5</b>	<b>Assembly.....</b>	<b>33</b>
5.1	Installing and connecting .....	33
5.2	Mechanical connection.....	34
5.2.1	SWS 001.....	35
5.2.2	SWS 005 / 011 .....	37
5.2.3	SWS 007 .....	39
5.2.4	SWS 011HM .....	41
5.2.5	SWS 020 / 021 / 022 / 041 / 060 .....	43
5.2.6	SWS 020HM / 021HM.....	45
5.2.7	SWS 029 .....	47
5.2.8	SWS 040Q / 071 .....	49
5.2.9	SWS 046 .....	52
5.2.10	SWS 076 / 110 / 160 .....	54
5.3	Pneumatic connection.....	56
5.3.1	Example for pneumatic control .....	56
5.3.2	SWS 001.....	57
5.3.3	SWS 005 .....	58
5.3.4	SWS 007 .....	58
5.3.5	SWS 011 .....	61
5.3.6	SWS 011HM .....	62
5.3.7	SWS 020 / 021 / 041 / 060 .....	63
5.3.8	SWS 020HM / 021HM.....	64
5.3.9	SWS 022.....	65
5.3.10	SWS 029 .....	66
5.3.11	SWS 040Q / 071 .....	67
5.3.12	SWS 046 .....	68
5.3.13	SWS 076 / 110 / 160 .....	69
5.4	Mounting the sensor.....	70
5.4.1	Overview of sensors .....	70
5.4.2	Check integrated piston stroke control .....	71
5.4.3	Mount and check external piston stroke control.....	73
5.4.4	Mount sensor ready-to-lock.....	82
5.4.5	Wrench sizes and tightening torques .....	83
5.5	Mount the optional module.....	84

<b>6 Troubleshooting.....</b>	<b>85</b>
6.1 Product does not lock or unlock .....	85
6.2 Electrical signals are not transmitted .....	86
6.3 Locking or unlocking signal faulty .....	86
6.4 Tool presence monitoring faulty .....	86
<b>7 Maintenance .....</b>	<b>87</b>
7.1 Notes.....	87
7.2 Maintenance intervals.....	87
7.3 Lubricants/greasing areas.....	88
7.4 Removing the product from the robot arm.....	89
7.5 Clean and lubricate product .....	90
7.6 Replace seals.....	93
7.6.1 Overview of the seals .....	93
7.6.2 Change O-ring .....	95
7.6.3 Change rubber bushing .....	96
7.6.4 Replace rubber bushing with sleeve .....	97
7.7 Change alignment pins.....	98
7.7.1 External alignment pins .....	98
7.7.2 Internal alignment pins.....	100
7.8 Change sensors.....	101
7.8.1 Change integrated piston stroke control .....	101
7.8.2 Change external piston stroke control.....	105
7.8.3 Change sensor ready-to-lock.....	108
7.9 Maintain option modules.....	109
7.9.1 Clean electric feed-through module .....	109
7.9.2 Replace V-ring seal on electric feed-through module.....	110
7.9.3 Change rubber bushing on the fluid feed-through module .....	111
7.10 Assembly drawings .....	112
7.10.1 SWS 001.....	112
7.10.2 SWS 005 .....	113
7.10.3 SWS 007 .....	114
7.10.4 SWS 011 .....	115
7.10.5 SWS 011HM .....	116
7.10.6 SWS 020 .....	117
7.10.7 SWS 020HM .....	118
7.10.8 SWS 021 .....	119
7.10.9 SWS 021HM .....	120
7.10.10 SWS 022.....	121
7.10.11 SWS 029 .....	122
7.10.12 SWS 040Q .....	123
7.10.13 SWS 041.....	124

7.10.14 SWS 046 .....	125
7.10.15 SWS 060 .....	126
7.10.16 SWS 071 .....	127
7.10.17 SWS 076 .....	128
7.10.18 SWS 110 .....	129
7.10.19 SWS-160 .....	130
<b>8 Translation of the original declaration of incorporation .....</b>	<b>131</b>
<b>9 UKCA declaration of incorporation .....</b>	<b>132</b>
<b>10 Information on the RoHS Directive, REACH Regulation and Substances of Very High Concern (SVHC) .....</b>	<b>133</b>

# 1 General

## 1.1 About this manual

This manual contains important information for a safe and appropriate use of the product.

This manual is an integral part of the product and must be kept accessible for the personnel at all times.

Before starting work, the personnel must have read and understood this operating manual. Prerequisite for safe working is the observance of all safety instructions in this manual.

In addition to these instructions, the documents listed under ▶ 1.1.3 [ 8 ] are applicable.

**NOTE:** The illustrations in this manual are intended to provide a basic understanding and may deviate from the actual version.

### 1.1.1 Presentation of Warning Labels

To make risks clear, the following signal words and symbols are used for safety notes.



#### **⚠ DANGER**

**Dangers for persons!**

Non-observance will inevitably cause irreversible injury or death.



#### **⚠ WARNING**

**Dangers for persons!**

Non-observance can lead to irreversible injury and even death.



#### **⚠ CAUTION**

**Dangers for persons!**

Non-observance can cause minor injuries.

#### **NOTICE**

**Material damage!**

Information about avoiding material damage.

### 1.1.2 Definition of Terms

The term "product" replaces the product name on the title page in this manual.

### 1.1.3 Applicable documents

- General terms of business \*
- Catalog data sheet of the purchased product \*
- Catalog data sheet for electric feed-through modules SWO-E and for fluid feed-through modules SWO-F
- Catalog data sheet for SWM storage racks

The documents labeled with an asterisk (\*) can be downloaded from [schunk.com/downloads](https://schunk.com/downloads).

### 1.2 Warranty

If the product is used as intended, the warranty is valid for 24 months from the ex-works delivery date under the following conditions:

- Observe the specified maintenance and lubrication intervals
- Observe the ambient conditions and operating conditions

Parts touching the workpiece and wear parts are not included in the warranty.

### 1.3 Scope of delivery

The scope of delivery includes

- Quick-Change System SWS in the version ordered, consisting of the following components
  - Quick-change master SWK
  - Quick-change adapter SWA
- Assembly and Operating Manual
- Accessory pack

### 1.4 Accessories

The following accessories are available for the product, which must be ordered separately:

- Electric modules SWO-E and fluid modules SWO-F
- Modular storage rack SWM
- Sensors for piston stroke control and presence monitoring of the SWA
- Dust cover SWD for quick-change adapter SWA
- Seal kit
- Cable connectors and cable extensions
- Adapter plates for screwing to the robot

For information regarding which accessory articles can be used with the corresponding product variants, see catalog data sheet.

### 1.4.1 Seal kit

Size	ID.-No. of the seal kit
SWS 001	available from SCHUNK on request
SWS 005	0370819
SWS 007	1371094
SWS 011	0370977
SWS 011HM	available from SCHUNK on request
SWK 020	0370821
SWA 020	0370822
SWS 020HM	available from SCHUNK on request
SWS 021	0370978
SWS 021HM	available from SCHUNK on request
SWS 022	1502927
SWS 029	1502940
SWS 040Q	0370949
SWS 041	0370979
SWS 046	1371095
SWS 060	0370824
SWS 071	0370980
SWS 076	0370948
SWS 110	0370806
SWS 160	0370992

## 2 Basic safety notes

### 2.1 Intended use

- The quick-change system SWS consists of a quick-change master SWK and a quick-change adapter SWA. It is exclusively intended for the automated changing of tools, e.g. grippers or other end effectors on robots.
- The quick-change master SWK is mounted on a robot. An end effector is mounted on the quick-change adapter SWA. By using an optionally available storage rack and several tools with quick-change adapters, the possibilities for automation are extended.
- When implementing and operating components in safety-related parts of the control systems, the basic safety principles in accordance with DIN EN ISO 13849-2 apply. The proven safety principles in accordance with DIN EN ISO 13849-2 also apply to categories 1, 2, 3 and 4.
- The product is intended for installation in a machine/ automated system. The applicable guidelines for the machine/ automated system must be observed and complied with.
- The product may only be used within the scope of its technical data, ▶ 3 [16].

#### Operating conditions

- Use only in covered or closed areas.
- Use in non-explosive areas.
- Only the substances permitted for the respective product should be fed through (fluids, electricity). All substances are only to be fed through the modules provided for this purpose. Never feed through corrosive or flammable gases.
- Only use the accessories permitted for the respective product.
- The product is intended for industrial and industry-oriented use.
- Appropriate use of the product includes compliance with all instructions in this manual.

### 2.2 Not intended use

Any use that exceeds or differs from the appropriate use is regarded as misuse. This includes in particular:

- Assembly on products that are not robots
- Use of the product as lifting equipment
- Outdoor use
- Use in potentially explosive areas

## 2.3 Constructional changes

### Implementation of structural changes

Modifications, changes or reworking, e.g. additional threads, holes, or safety devices, can damage the product or impair its functionality or safety.

- Structural changes should only be made with the written approval of SCHUNK.

## 2.4 Spare parts

### Use of unauthorized spare parts

Using unauthorized spare parts can endanger personnel and damage the product or cause it to malfunction.

- Use only original spare parts or spares authorized by SCHUNK.

## 2.5 Ambient conditions and operating conditions

### Required ambient conditions and operating conditions

Incorrect ambient and operating conditions can make the product unsafe, leading to the risk of serious injuries, considerable material damage and/or a significant reduction to the product's life span.

- Make sure that the product is used only in the context of its defined application parameters, ▶ 3 [16].

## 2.6 Personnel qualification

### Inadequate qualifications of the personnel

If the personnel working with the product is not sufficiently qualified, the result may be serious injuries and significant property damage.

- All work may only be performed by qualified personnel.
- Before working with the product, the personnel must have read and understood the complete assembly and operating manual.
- Observe the national safety regulations and rules and general safety instructions.

The following personal qualifications are necessary for the various activities related to the product:

#### Trained electrician

Due to their technical training, knowledge and experience, trained electricians are able to work on electrical systems, recognize and avoid possible dangers and know the relevant standards and regulations.

<b>Qualified personnel</b>	Due to its technical training, knowledge and experience, qualified personnel is able to perform the delegated tasks, recognize and avoid possible dangers and knows the relevant standards and regulations.
<b>Instructed person</b>	Instructed persons were instructed by the operator about the delegated tasks and possible dangers due to improper behaviour.
<b>Service personnel of the manufacturer</b>	Due to its technical training, knowledge and experience, service personnel of the manufacturer is able to perform the delegated tasks and to recognize and avoid possible dangers.

## 2.7 Personal protective equipment

### Use of personal protective equipment

Personal protective equipment serves to protect staff against danger which may interfere with their health or safety at work.

- When working on and with the product, observe the occupational health and safety regulations and wear the required personal protective equipment.
- Observe the valid safety and accident prevention regulations.
- Wear protective gloves to guard against sharp edges and corners or rough surfaces.
- Wear heat-resistant protective gloves when handling hot surfaces.
- Wear protective gloves and safety goggles when handling hazardous substances.
- Wear close-fitting protective clothing and also wear long hair in a hairnet when dealing with moving components.

## 2.8 Notes on safe operation

### Incorrect handling of the personnel

Incorrect handling and assembly may impair the product's safety and cause serious injuries and considerable material damage.

- Avoid any manner of working that may interfere with the function and operational safety of the product.
- Use the product as intended.
- Observe the safety notes and assembly instructions.
- Do not expose the product to any corrosive media. This does not apply to products that are designed for special environments.
- Eliminate any malfunction immediately.
- Observe the care and maintenance instructions.

- Observe the current safety, accident prevention and environmental protection regulations regarding the product's application field.

## 2.9 Transport

### Handling during transport

Incorrect handling during transport may impair the product's safety and cause serious injuries and considerable material damage.

- When handling heavy weights, use lifting equipment to lift the product and transport it by appropriate means.
- Secure the product against falling during transportation and handling.
- Stand clear of suspended loads.

## 2.10 Malfunctions

### Behavior in case of malfunctions

- Immediately remove the product from operation and report the malfunction to the responsible departments/persons.
- Order appropriately trained personnel to rectify the malfunction.
- Do not recommission the product until the malfunction has been rectified.
- Test the product after a malfunction to establish whether it still functions properly and no increased risks have arisen.

## 2.11 Disposal

### Handling of disposal

The incorrect handling of disposal may impair the product's safety and cause serious injuries as well as considerable material and environmental harm.

- Follow local regulations on dispatching product components for recycling or proper disposal.

## 2.12 Fundamental dangers

### General

- Observe safety distances.
- Never deactivate safety devices.
- Before commissioning the product, take appropriate protective measures to secure the danger zone.

- Disconnect power sources before installation, modification, maintenance, or calibration. Ensure that no residual energy remains in the system.
- If the energy supply is connected, do not move any parts by hand.
- Do not reach into the open mechanism or movement area of the product during operation.

### **2.12.1 Protection during handling and assembly**

#### **Incorrect handling and assembly**

Incorrect handling and assembly may impair the product's safety and cause serious injuries and considerable material damage.

- Have all work carried out by appropriately qualified personnel.
- For all work, secure the product against accidental operation.
- Observe the relevant accident prevention rules.
- Use suitable assembly and transport equipment and take precautions to prevent jamming and crushing.

#### **Incorrect lifting of loads**

Falling loads may cause serious injuries and even death.

- Stand clear of suspended loads and do not step into their swiveling range.
- Never move loads without supervision.
- Do not leave suspended loads unattended.

### **2.12.2 Protection during commissioning and operation**

#### **Falling or violently ejected components**

Falling and violently ejected components can cause serious injuries and even death.

- Take appropriate protective measures to secure the danger zone.
- Never step into the danger zone during operation.

### **2.12.3 Protection against dangerous movements**

#### **Unexpected movements**

Residual energy in the system may cause serious injuries while working with the product.

- Switch off the energy supply, ensure that no residual energy remains and secure against inadvertent reactivation.
- Never rely solely on the response of the monitoring function to avert danger. Until the installed monitors become effective, it must be assumed that the drive movement is faulty, with its

action being dependent on the control unit and the current operating condition of the drive. Perform maintenance work, modifications, and attachments outside the danger zone defined by the movement range.

- To avoid accidents and/or material damage, human access to the movement range of the machine must be restricted. Limit/prevent accidental access for people in this area due through technical safety measures. The protective cover and protective fence must be rigid enough to withstand the maximum possible movement energy. EMERGENCY STOP switches must be easily and quickly accessible. Before starting up the machine or automated system, check that the EMERGENCY STOP system is working. Prevent operation of the machine if this protective equipment does not function correctly.

### 2.13 Notes on particular risks



#### **⚠ WARNING**

##### **Risk of injury due to unexpected movements!**

If the power supply is switched on or residual energy remains in the system, components can move unexpectedly and cause serious injuries.

- Before starting any work on the product: Switch off the power supply and secure against restarting.
- Make sure, that no residual energy remains in the system.



#### **⚠ WARNING**

##### **Risk of crushing from objects falling and being ejected!**

During operation, the load can no longer be held if the maximum permissible load is exceeded, if a component breaks or if the pressure drops.

- Check product for damage before operation. Arrange for repairs if necessary.
- Observe maintenance intervals.
- Take suitable protective measures to secure the danger zone.

### 3 Technical data

#### 3.1 Basic data

SWS	Weight [kg]		Recommended handling weight [kg]	Max. moment [Nm]	
	SWK	SWA		$M_x$ and $M_y$	$M_z$
001	0.03	0.02	1.4	2.8	3.45
005	0.27	0.09	8	37.5	51
007	0.16	0.08	16	61	38
011	0.13	0.09	16	61	38
011HM	0.29	0.09	16	20.3	12.4
020	0.69	0.32	25	169.5	105
020HM	0.68	0.32	25	56.5	78
021	0.5	0.3	25	169.5	105
021HM	0.7	0.3	25	56.5	78
022	0.87	0.55	25	169.5	230
029	0.98	0.67	35	169.5	230
040Q	1.27	0.6	50	471	648
041	1.4	0.7	50	471	648
046	1.95	1.03	50	678	450
060	1.3	0.7	75	591	326
071	1.8	1.3	79	1185	378
076	2.25	1.43	100	1626	2103
110	4	2.2	150	2352	2352
160	6.44	2.86	300	7170	3800

More technical data is included in the catalog data sheet. Whichever is the latest version.

### 3.2 Ambient conditions and operating conditions

#### All SWS sizes

Designation	SWS
Ambient temperature [°C]	
min.	+5
max.	+60
Pressure medium	Compressed air, compressed air quality according to ISO 8573-1:2010 [7:4:4]
Permissible pressure range [bar]	4.5-6.9

\* For use in dirty ambient conditions (e.g. sprayed water, vapors, abrasion or processing dust) SCHUNK offers corresponding product options as standard. SCHUNK also offers customized solutions for special applications in dirty ambient conditions.

### 3.3 Max. permissible offset when mounting the SWA with end effector

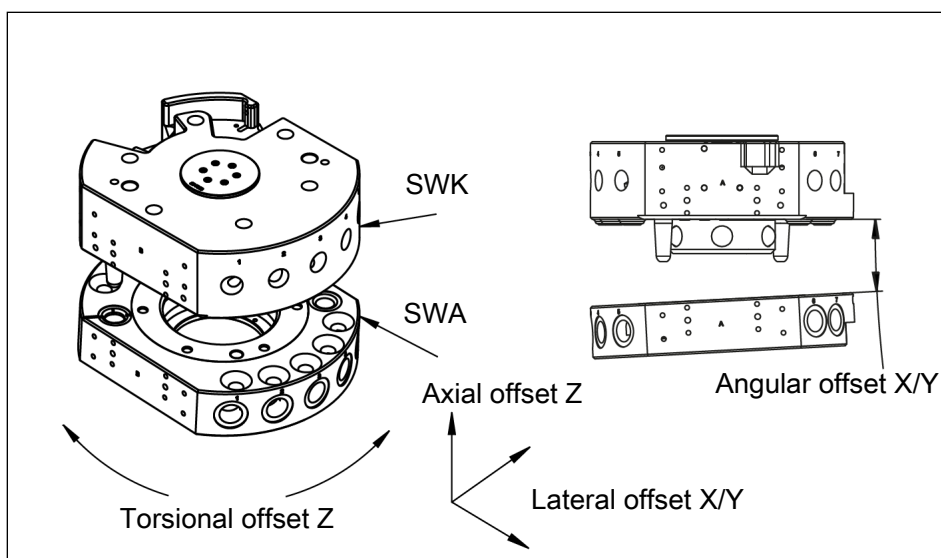

Offset definition

SWS	Max. torsional offset Z [°]	Max. axial offset Z [mm] *	Max. lateral offset XY [mm] **	Max. angular offset XY [°]
001	±1	3	±2	±0.7
005	±2	2	±1	±1.1
007	±2	1.5	±1	±1.5
011	±2	1.5	±1	±0.8
011HM	±2	1.5	±1	±0.8
020	±2	2	±1	±0.8
020HM	±2	2	±1	±0.8

SWS	Max. torsional offset Z [°]	Max. axial offset Z [mm] *	Max. lateral offset XY [mm] **	Max. angular offset XY [°]
021	±2	2	±1	±0.8
021HM	±2	2	±1	±0.8
022	±2	2	±1	±0.8
029	±1	1.5	±0.9	±0.8
040Q	±2	5	±2	±1.0
041	±2	3	±2	±1.0
046	±2	2.5	±1.5	±1.0
060	±1	3	±2	±0.6
071	±1	3	±2	±0.6
076	±1	2	±1	±1.0
110	±1	3	±1	±0.7
160	±1	2.5	±2	±0.7

\* Maximum values specified. By reducing the actual values, the wear and tear during coupling / decoupling is minimized.

\* The actual values may be higher in some cases. However, higher

\* offset values increase the wear and tear during coupling / decoupling.

## 4 Design and description

### 4.1 Description

Quick-change systems (SWS) enable automated tool change and consist of two components:

- Quick-change master SWK: The SWK is connected to the robot and, together with the SWA, forms the interface between the robot and the end effector.
- Quick-change adapter SWA: The SWA is connected to the end effector. If different tools are used with an SWK, each end effector is equipped with an SWA. The unused tools are stored by the robot in a storage rack during when not being used.

Storage racks are optionally available as accessories from SCHUNK.

#### 4.1.1 Functional principle

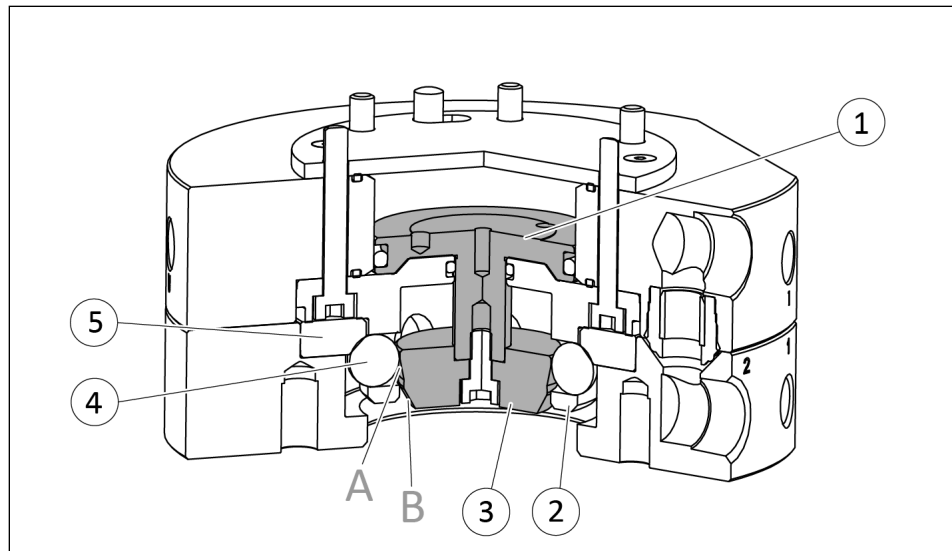

*Schematic diagram of locking mechanism*

1	Locking piston
2	Male coupling
3	Cam
4	Locking ball
5	Bearing race

#### Locking

The cam (3) is attached to the locking piston (1) and has two bevels. When the locking piston (1) is actuated, the cam (3) with the bevel A presses the locking balls (4) under the hardened bearing race (5). This presses SWK and SWA together. In the locked state, the locking balls are between the male coupling (2) and the incline B of the cam (3). The bevel B (fail-safe reverse

taper) causes a high locking force. Therefore, separation of SWK and SWA in the self-locking state is only possible by pneumatic or manual actuation of the locking piston.

### **Unlocking**

If the locking piston is actuated again, the cam (3) moves in the opposite direction. The locking balls (4) release from the hardened bearing race (5). The SWK is in the unlocked state and the SWA can be separated from the SWK.

## 4.2 Design

### 4.2.1 SWS 001

#### SWK

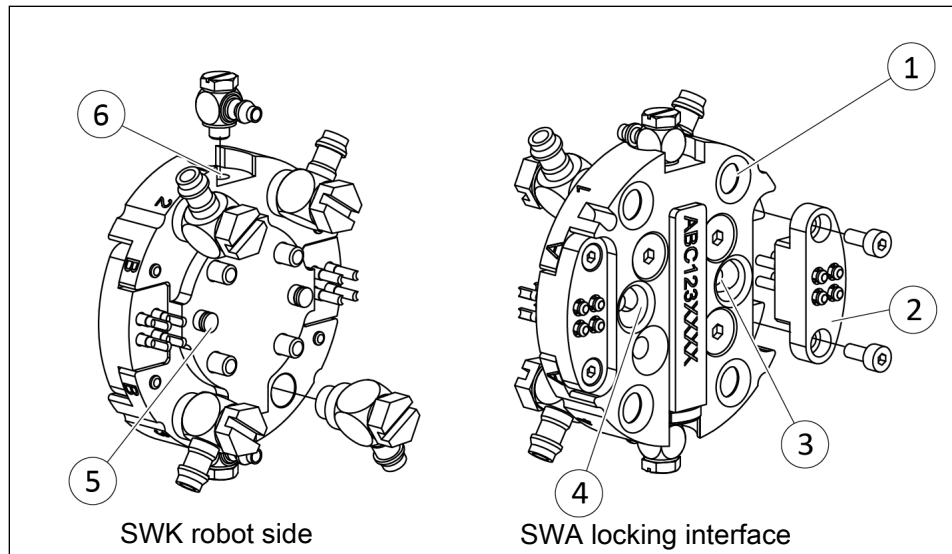

Design SWK 001

- 1 Pneumatic feed-through with 0-ring

---

- 2 Optional module

---

- 3 Alignment pin

---

- 4 Locking mechanism

---

- 5 Dowel pin

---

- 6 Air supply lock and unlock

#### SWA

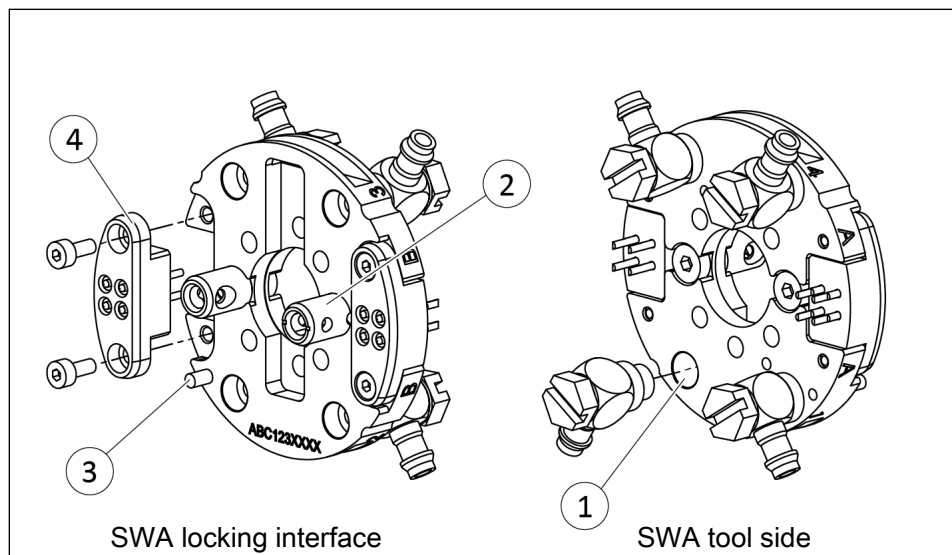

Design SWA 001

- 1 Port for pneumatic feed-through

---

- 2 Centering / locking sleeve

---

- 3 Dowel pin

---

- 4 Optional module

### 4.2.2 SWS 005

SWK

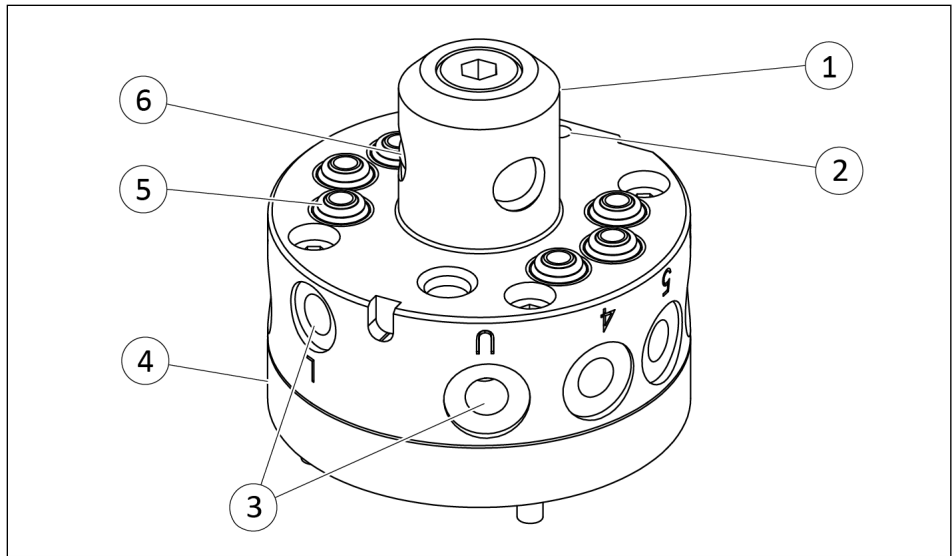

Design SWK 005

- 1 Locking mechanism

---

- 2 Alignment pin bushing

---

- 3 Air supply lock and unlock  
(observe reverse piston direction)

---

- 4 Cover plate

---

- 5 Pneumatic feed-through with rubber bushing

---

- 6 Locking ball

SWA

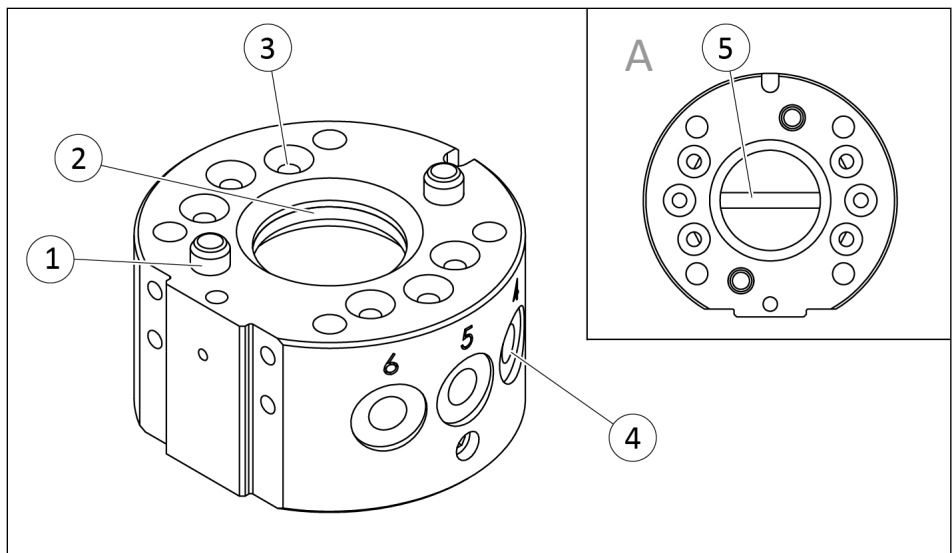

Design SWA 005, A = view from above

- 1 Alignment pin

---

- 2 Bearing race

---

- 3 Pneumatic feed-through

---

- 4 Port for pneumatic feed-through

---

- 5 Release bolts

### 4.2.3 SWS 007

SWK

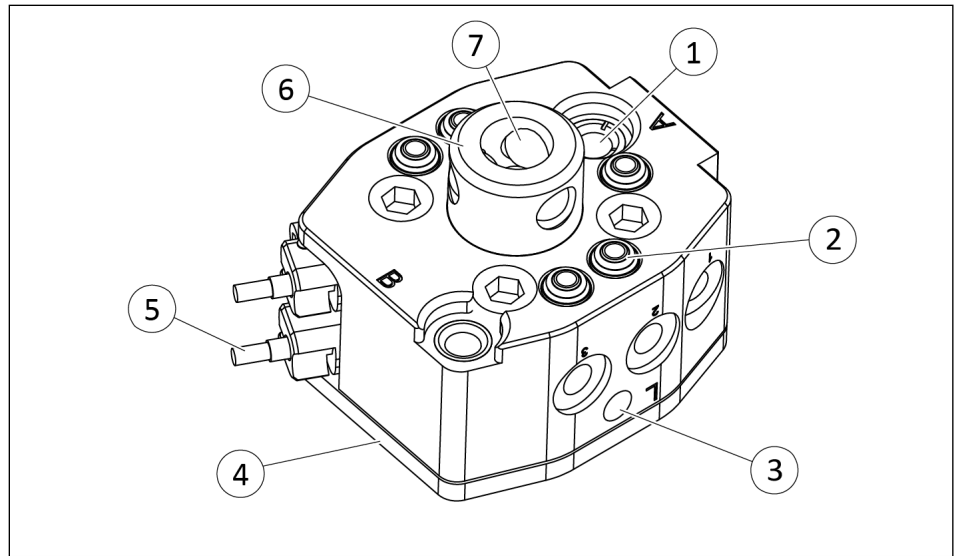

Design SWK 007

- 1 Alignment pin bushing

---

- 2 Pneumatic feed-through with rubber bushing

---

- 3 Air supply lock

---

- 4 Cover plate

---

- 5 Integrated piston stroke control

---

- 6 Locking mechanism

---

- 7 Locking ball

SWA

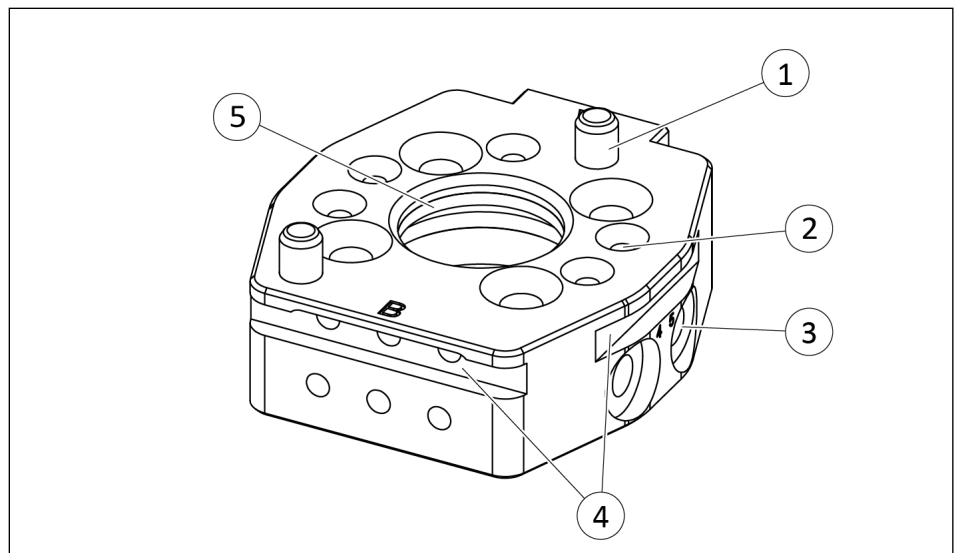

Design SWA 007

- 1 Alignment pin

---

- 2 Pneumatic feed-through

---

- 3 Port for pneumatic feed-through

---

- 4 Slot for depositing in storage rack

---

- 5 Bearing race

### 4.2.4 SWS 011

SWK

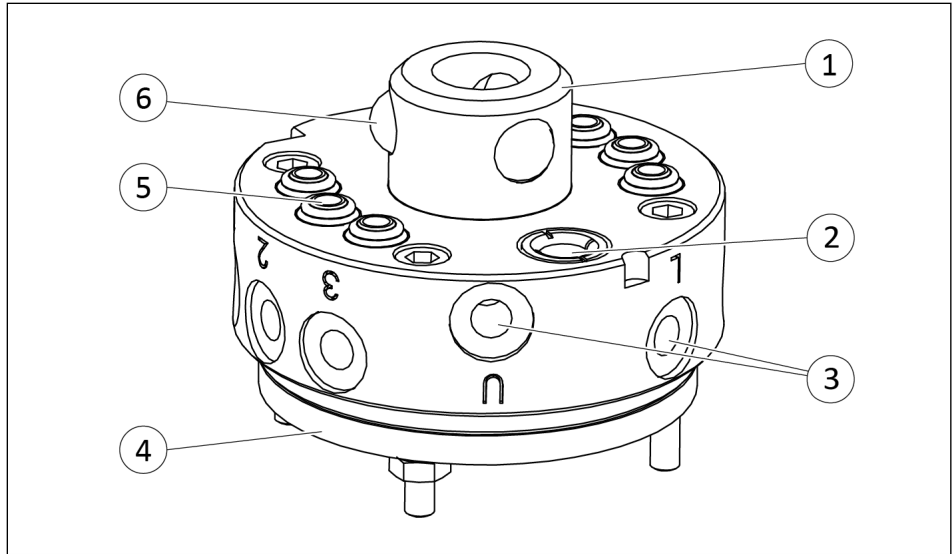

Design SWK 011

- 1 Locking mechanism
- 2 Alignment pin bushing
- 3 Air supply lock and unlock
- 4 Cover plate
- 5 Pneumatic feed-through with rubber bushing
- 6 Locking ball

SWA

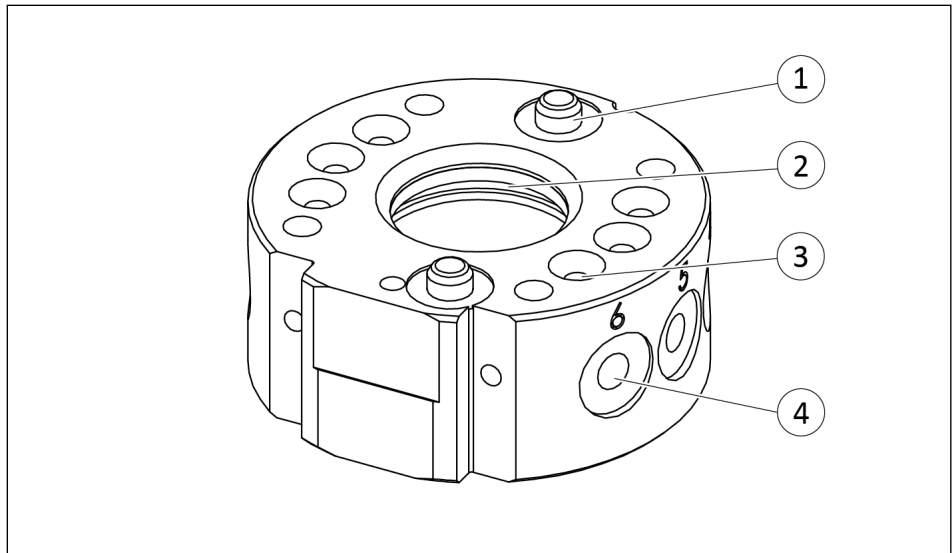

Design SWA 011

- 1 Alignment pin
- 2 Bearing race
- 3 Pneumatic feed-through
- 4 Port for pneumatic feed-through

### 4.2.5 SWS 011HM

SWK

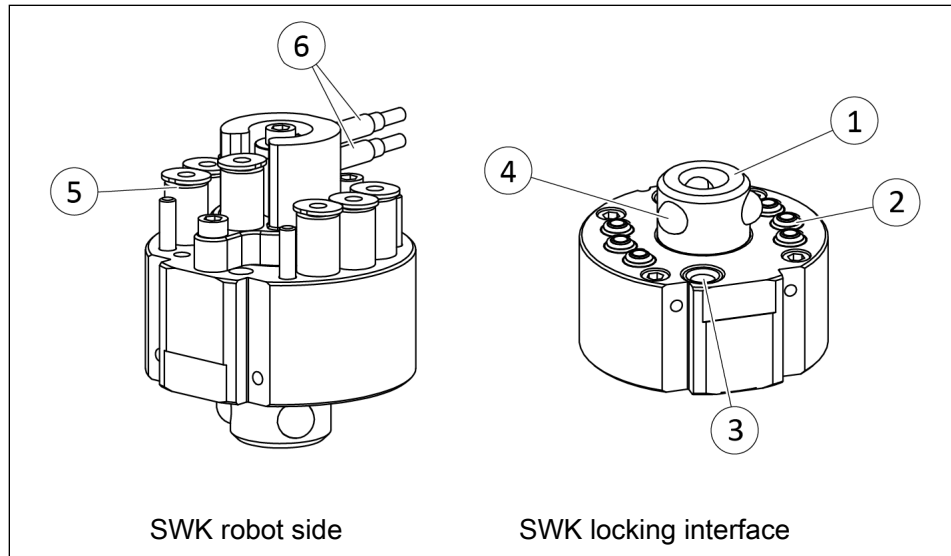

Design SWK 011HM

- 1 Locking mechanism

---

- 2 Pneumatic feed-through with rubber bushing

---

- 3 Alignment pin bushing

---

- 4 Locking ball

---

- 5 Air supply lock and unlock

---

- 6 Integrated piston stroke control

---

SWA

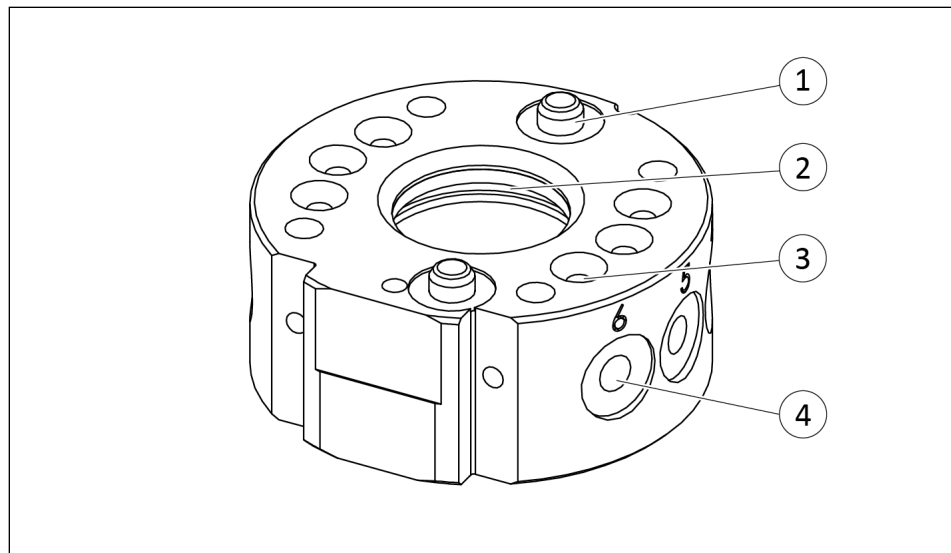

Design SWA 011

- 1 Alignment pin

---

- 2 Bearing race

---

- 3 Pneumatic feed-through

---

- 4 Port for pneumatic feed-through

---

### 4.2.6 SWS 020 / 021 / 041 / 060

#### NOTE

The rubber bushings are located at the SWS 020 in SWA and not, as shown here, in SWK.

SWK

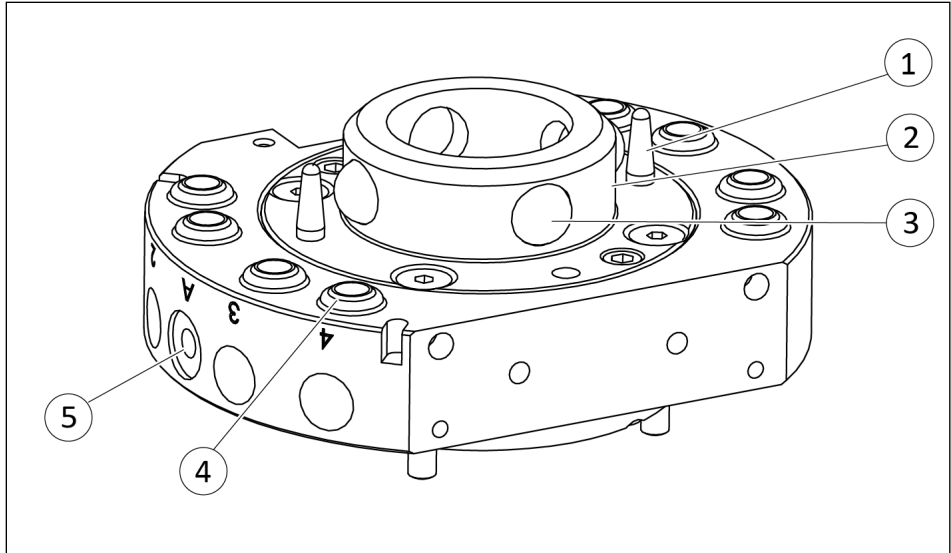

Exemplary design shown on SWK 021

- 1 Alignment pin
- 2 Locking mechanism
- 3 Locking ball
- 4 Pneumatic feed-through with rubber bushing
- 5 Air supply lock and unlock

SWA

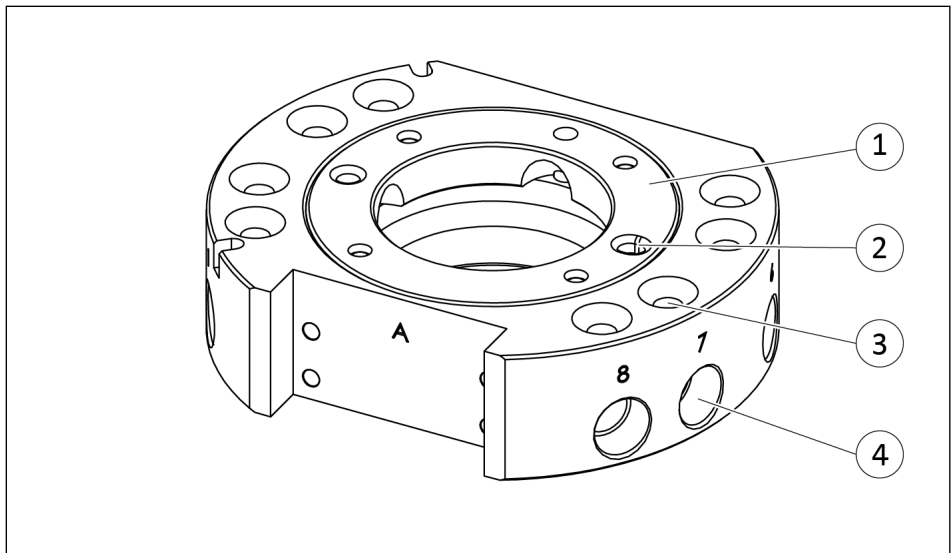

Exemplary design shown on SWA 021

- 1 Bearing race with recesses for locking balls
- 2 Alignment pin bushing
- 3 Pneumatic feed-through
- 4 Port for pneumatic feed-through

### 4.2.7 SWS 020HM / 021HM

SWK

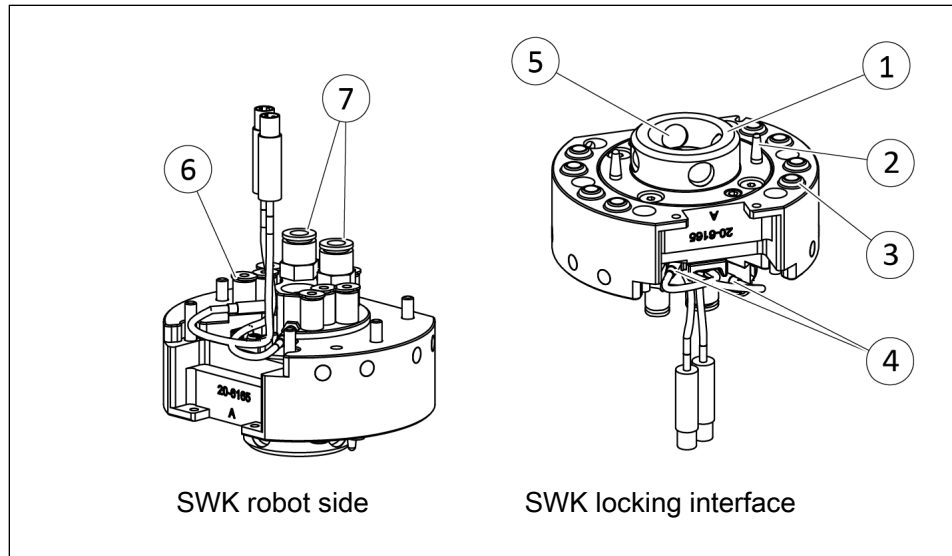

Exemplary design shown on SWK 021HM

- 1 Locking mechanism

---

- 2 Alignment pin

---

- 3 Pneumatic feed-through with rubber bushing

---

- 4 Integrated piston stroke control

---

- 5 Locking ball

---

- 6 Air supply lock and unlock

---

- 7 Port for pneumatic feed-through

---

SWA

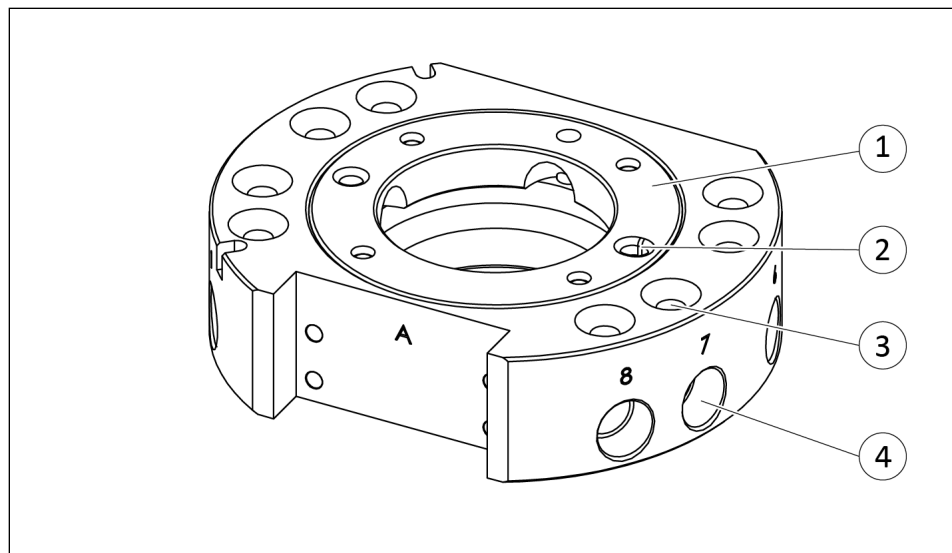

Exemplary design shown on SWA 021

- 1 Bearing race with recesses for locking balls

---

- 2 Alignment pin bushing

---

- 3 Pneumatic feed-through

---

- 4 Port for pneumatic feed-through

---

### 4.2.8 SWS 022

#### SWK

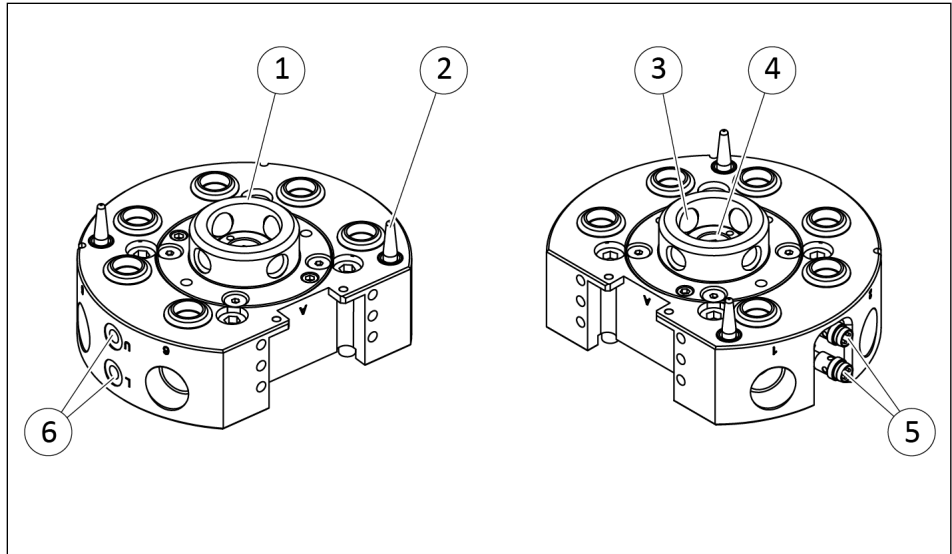

Design SWK 022

- 1 Locking mechanism
- 2 Alignment pin
- 3 Locking ball
- 4 Locking piston
- 5 Integrated piston stroke control
- 6 Air supply lock and unlock

#### SWA

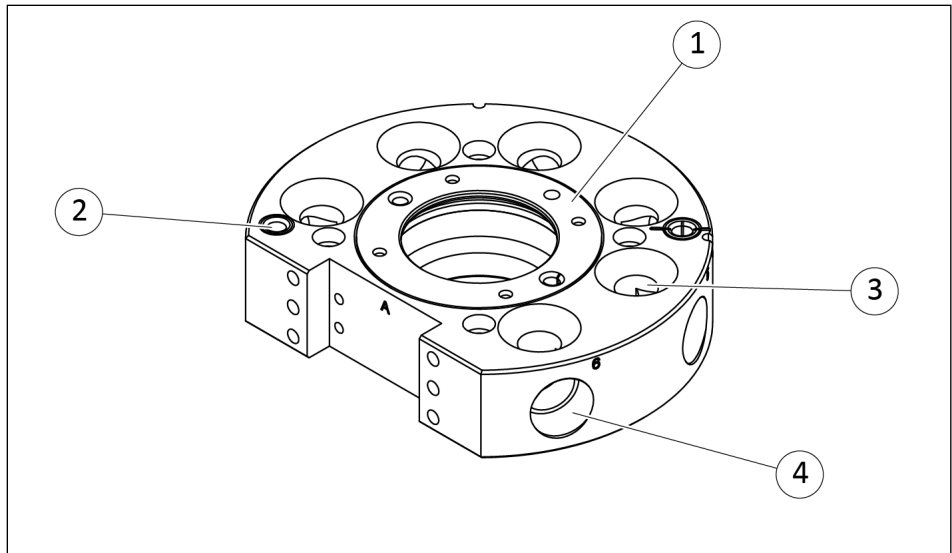

Design SWA 022

- 1 Bearing race with recesses for locking balls
- 2 Alignment pin bushing
- 3 Pneumatic feed-through
- 4 Port for pneumatic feed-through

## 4.2.9 SWS 029

SWK

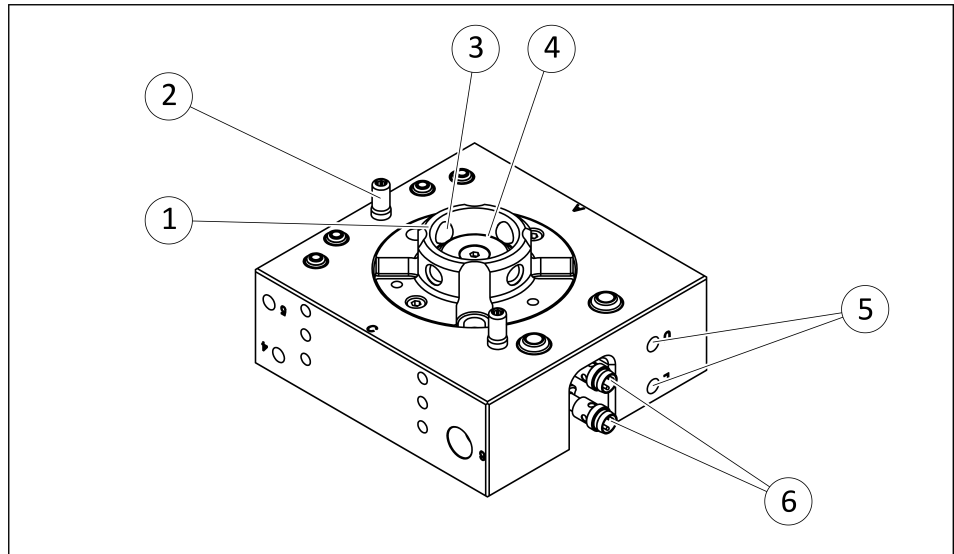

Design SWK 029

- 1 Locking mechanism

---

- 2 Alignment pin

---

- 3 Locking ball

---

- 4 Locking piston

---

- 5 Air supply lock and unlock

---

- 6 Integrated piston stroke control

---

SWA

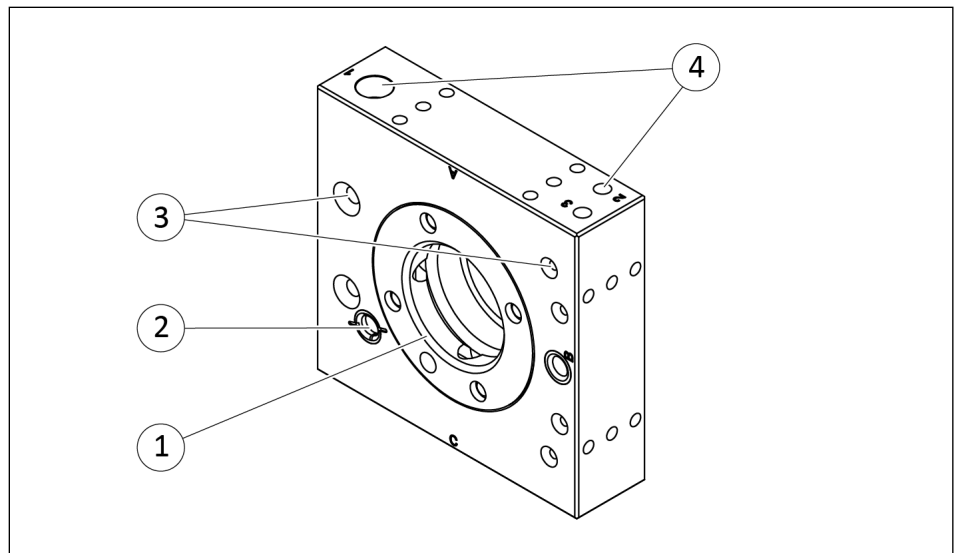

Design SWA 029

- 1 Bearing race with recesses for locking balls

---

- 2 Alignment pin bushing

---

- 3 Pneumatic feed-through

---

- 4 Port for pneumatic feed-through

---

### 4.2.10 SWS 040Q / 071

**SWK**

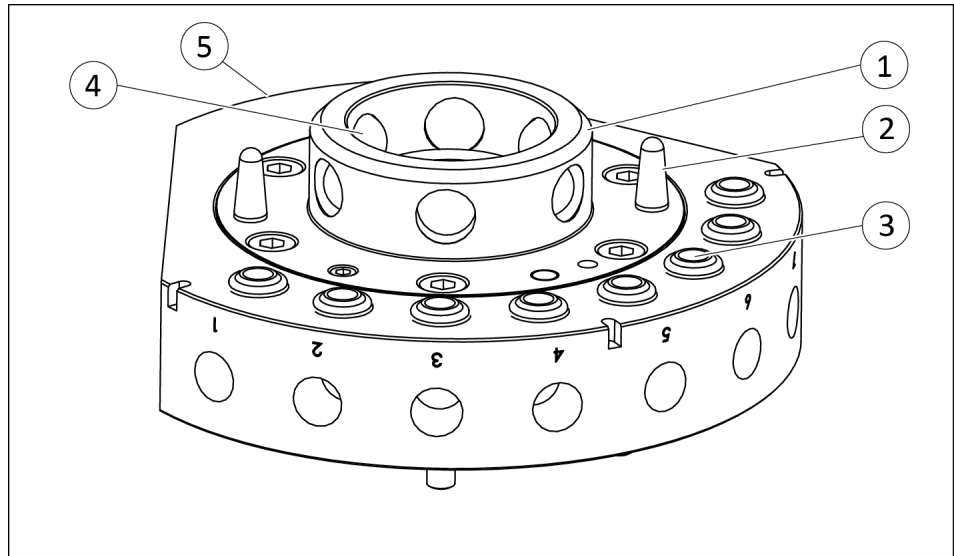

*Exemplary design shown on SWK 071*

- 1 Locking mechanism
- 2 Alignment pin
- 3 Pneumatic feed-through with rubber bushing
- 4 Locking ball
- 5 Air supply lock and unlock

**SWA**

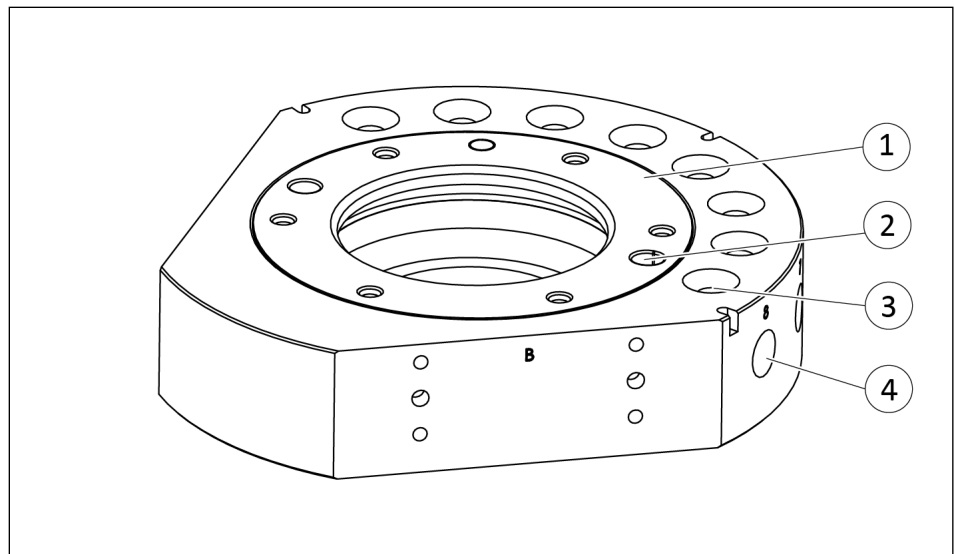

*Exemplary design shown on SWA 071*

- 1 Bearing race
- 2 Alignment pin bushing
- 3 Pneumatic feed-through
- 4 Port for pneumatic feed-through

### 4.2.11 SWS 046

SWK

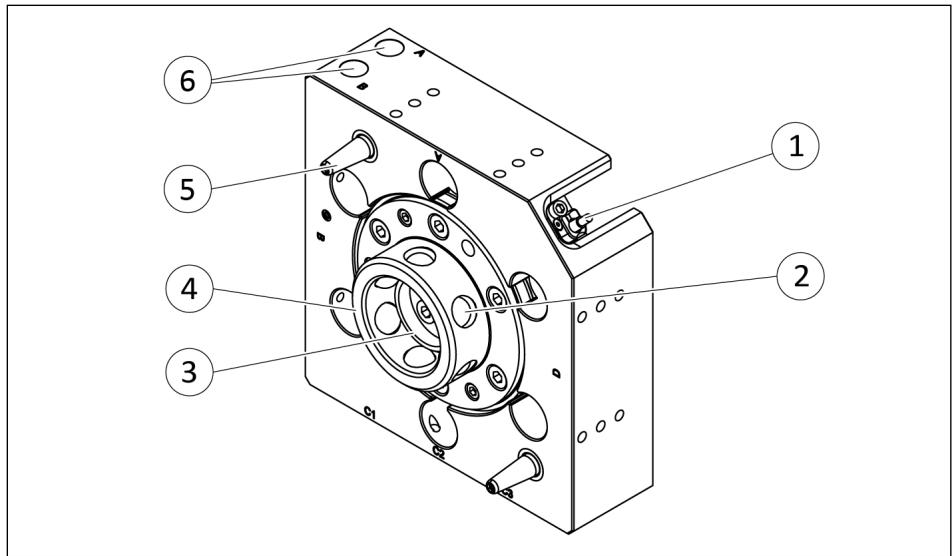

Design SWK 046

- 1 Integrated piston stroke control

---

- 2 Locking ball

---

- 3 Locking piston

---

- 4 Locking mechanism

---

- 5 Alignment pin

---

- 6 Air supply lock and unlock

---

SWA

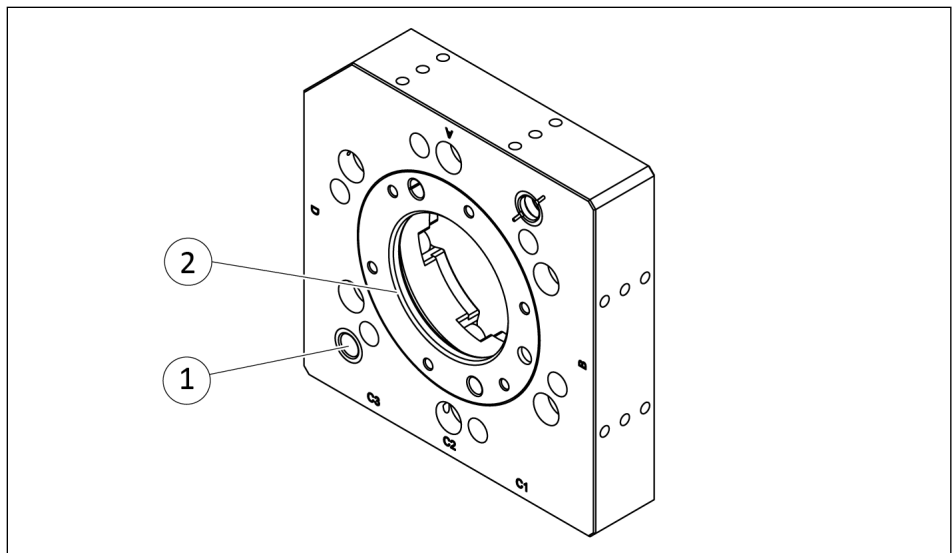

Design SWA 046

- 1 Alignment pin bushing

---

- 2 Bearing race

---

### 4.2.12 SWS 076 / 110 / 160

#### SWK

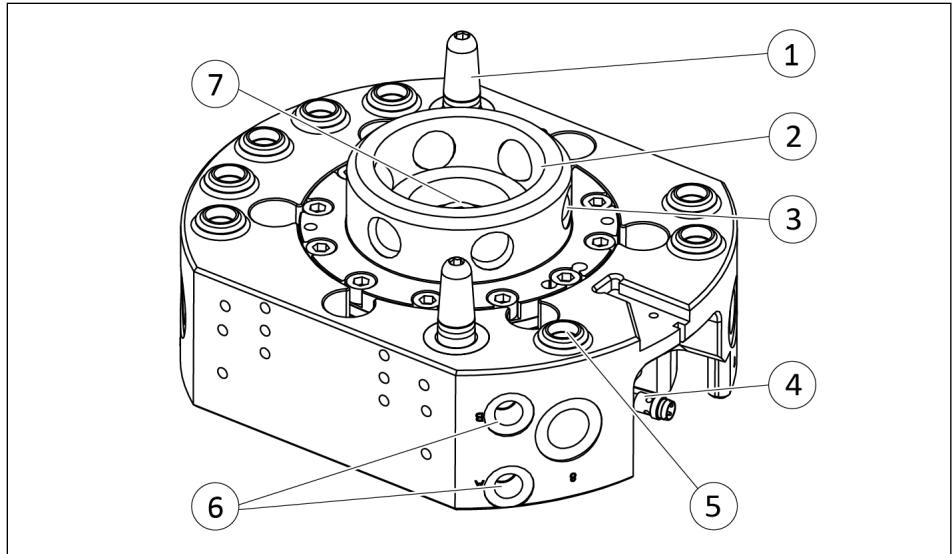

Exemplary design shown on SWK 110

- 1 Alignment pin
- 2 Locking mechanism
- 3 Locking ball
- 4 Integrated piston stroke control
- 5 Pneumatic feed-through with rubber bushing
- 6 Air supply lock and unlock
- 7 Locking piston

#### SWA

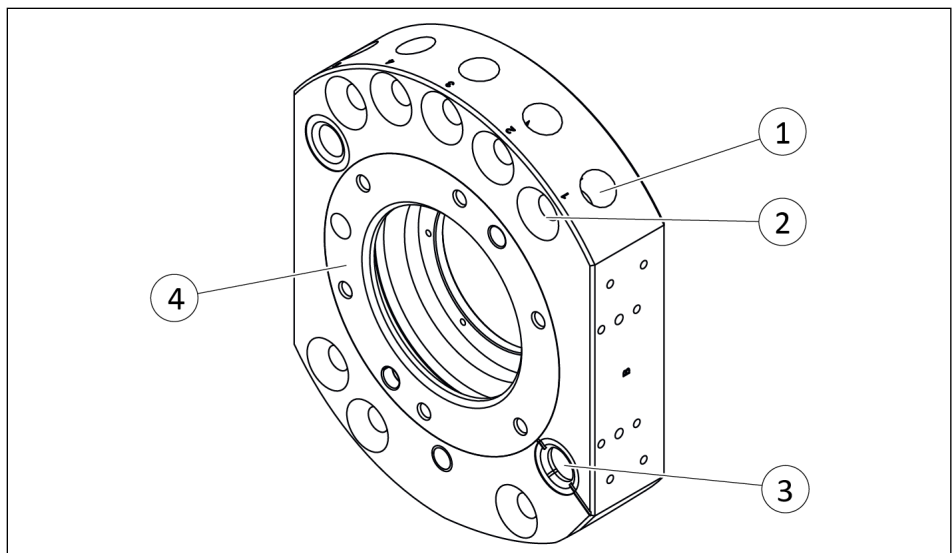

Exemplary design shown on SWA 110

- 1 Port for pneumatic feed-through
- 2 Pneumatic feed-through
- 3 Alignment pin bushing
- 4 Bearing race

## 5 Assembly

### 5.1 Installing and connecting



#### **⚠ WARNING**

##### **Risk of injury due to unexpected movements!**

If the power supply is switched on or residual energy remains in the system, components can move unexpectedly and cause serious injuries.

- Before starting any work on the product: Switch off the power supply and secure against restarting.
- Make sure, that no residual energy remains in the system.



#### **⚠ WARNING**

##### **Risk of injury due to improperly carried out assembly!**

Improperly carried out assembly work can lead to severe injuries and property damage.

- Before beginning work, ensure sufficient assembly clearance.
- Secure components from falling down or over.
- Ensure that all work has been carried out in accordance with the specifications in these instructions.
- Observe tightening torques.

1. Check the evenness of the mounting surface, ▶ 5.2 [ 34].
2. Attach the product to the robot, ▶ 5.2 [ 34].
  - ⇒ Observe the maximal tightening torque, admissible screw-in depth and, if necessary, strength class.
3. Connect pneumatic connections to compressed air supply via a suitable 4 or 5-way valve, ▶ 5.3 [ 56]
4. Mount sensors if necessary, ▶ 5.4 [ 70].
5. Mount optional modules if necessary, ▶ 5.5 [ 84]
6. Make sure that the connections are not stressed due to tensile and pressure forces. Apply appropriate strain relief devices if required.

## 5.2 Mechanical connection

### NOTE

- Secure all screws with Loctite®. To do this, apply adhesive to the exposed screw threads.
  - ⇒ Use adhesive only once. Always apply new adhesive if reusing fastening elements.
- Mounted screws may not protrude above the surface! Select screws so that they are flush with the surfaces and screw them together without washers.

### Evenness of the mounting surface

The values apply to the whole mounting surface to which the product is mounted.

Edge length	Permissible unevenness
< 100	< 0.02
> 100	< 0.05

Tab.: Requirements for evenness of the mounting surface (Dimensions in mm)

### Adapter plate requirements

An adapter plate can be used for mounting the SWK on the robot and the end effector on the SWA. An adapter plate is necessary if the screw connection diagram of the SWS has to be adapted to the customer's equipment (robot flange, end effector). **NOTICE! Only use adapter plates if they have bores and recesses that match the product exactly. Precisely fitting installation is a prerequisite for the function.**

The adapter plate must meet the following requirements:

- The adapter plate requires bores for the mounting screws with sufficient thread depth for mounting on the robot.
- The adapter plate requires centering recesses for dowel pins with sufficient depth so that no gap is created during assembly.
- Depending on the robot flange, the adapter plate requires a centering plate on the robot side and a centering recess at the interface to the SWK robot side.
- Depending on the end effector, the adapter plate requires a centering plate on the SWA tool side and a centering recess at the interface to the end effector.
- For sizes with an external piston stroke control, the adapter plate requires a recess adapted to the sensor outlet.

The catalog data sheet contains detailed information and precise manufacturing instructions for possible adapter plate design.

**NOTE**

The mounting of the SWK with an external piston stroke control is described in chapter ▶ 5.4.3 [ 73].

**5.2.1 SWS 001**

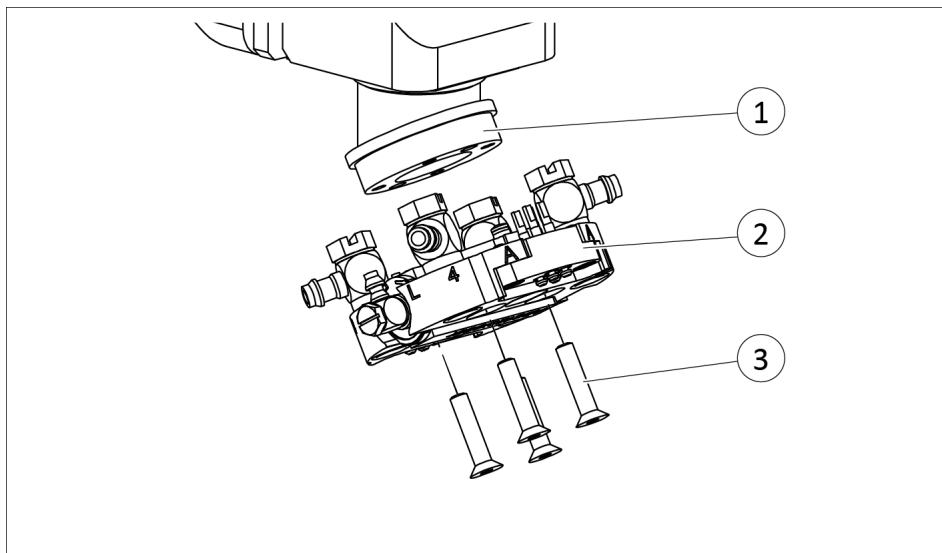

Mounting on robot for SWK 001

1. Clean the mounting patterns on the robot (1) and SWK (2).
2. Mount optional adapter plate between the robot and SWK.
3. Insert the SWK (2) with integrated dowel pins into the bores on the robot.
4. Apply screw lock to screws (3).
5. Secure SWK (2) to robot (1) with screws (3).  
 ⇒ Observe the tightening torque for the mounting screws.

Item	Mounting	SWK 001
3	Mounting screw according to standard	M3 x 14, DIN EN ISO 10642
	Strength class	8.8
	Max. tightening torque [Nm]	0.79
	Threadlocker	Loctite ® 222

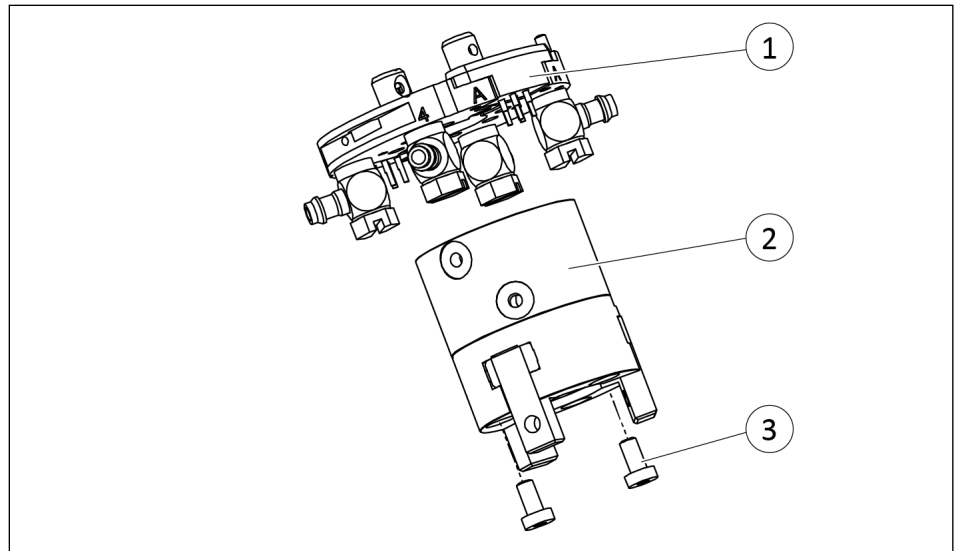

*Mount the end effector to SWA 001*

- 1.** Clean the mounting patterns on the SWA (1) and end effector (2).
- 2.** Mount optional adapter plate between SWA and end effector.
- 3.** Secure the end effector (2) with screws (3).
  - ⇒ Observe the tightening torque for the mounting screws.



**7. In the event that the cover plate (6) has to be removed:**

Remove the cover plate (6) from the SWK (7).

**NOTICE! Product may leak! When removing the cover plate, ensure that the O-ring remains in the SWK**

- 8. Insert dowel pin (5) into bore on cover plate / SWK.
- 9. Apply screw lock to screws (8).
- 10. Insert SWK (7) with dowel pin (5) into the bore in the adapter plate.
- 11. Secure SWK (7) to adapter plate (3) with screws (8).
  - ⇒ Observe the tightening torque for the mounting screws.

Item	Mounting	SWK 005	SWK 011
5	Alignment pin	∅ 3 x 8	∅ 3 x 10
8	Mounting screw according to standard	M3 x 25, DIN EN ISO 4762	
	Strength class	8.8	
	Max. tightening torque [Nm]	1.13	
	Threadlocker	Loctite ® 222	

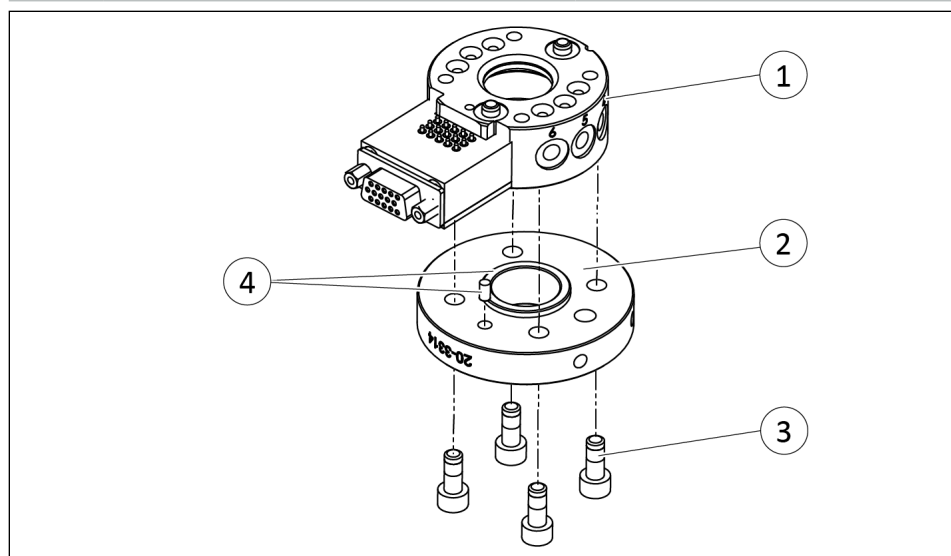

Mount adapter plate (shown as an example) to SWA, illustrated on SWA 011

- 1. Clean mounting surfaces on SWA (1) and adapter plate (2).
- 2. Insert the adapter plate (2) with two alignment pins and/or with one alignment pin and the centering collar on the adapter plate (4) into the holes provided for this purpose.
- 3. Fasten the adapter plate (2) to the SWA (1) with screws (3).
  - ⇒ Observe the tightening torque for the mounting screws.
- 4. Mount the end effector.

### 5.2.3 SWS 007

#### NOTE

The product in this size has an ISO flange as standard. When using a robot without ISO flange interface, the product can be mounted to the robot using an adapter plate.

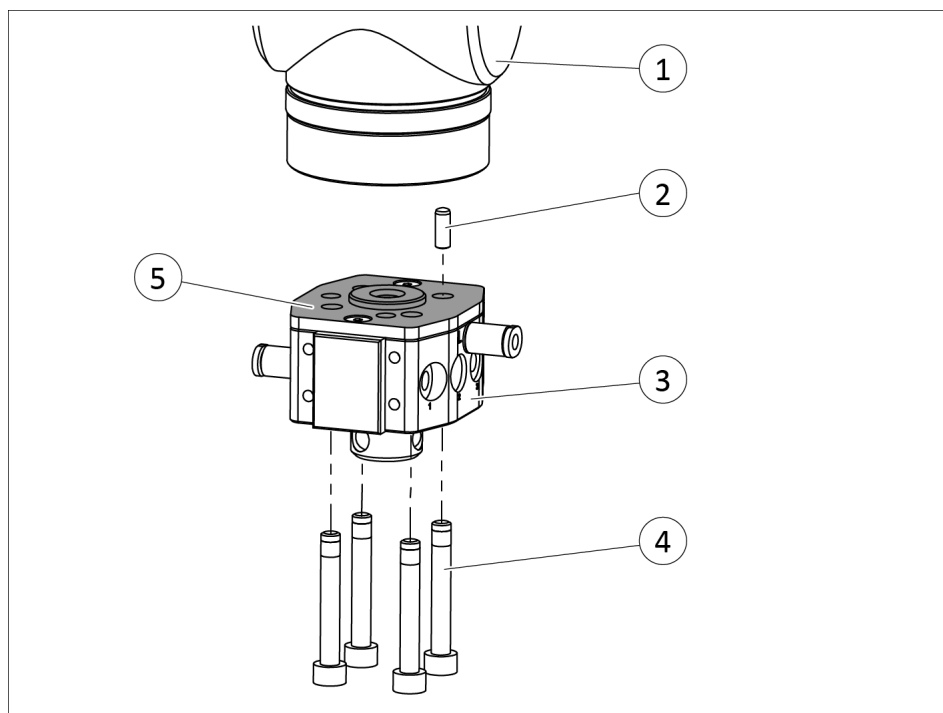

Mounting on robot for SWK 007

1. Clean the mounting surfaces on the robot (1) and SWK (3).
2. **For mounting on a robot without ISO flange interface:**  
Mount adapter plate between robot (1) and SWK (3).
3. Insert alignment pin (2) in SWK (3).
4. Apply screw lock to screws (4).
5. Align SWK with alignment pin (2) on robot and insert SWK (3) with centering collar (5) into the fitting bore on the robot (1).
6. Secure SWK (3) with screws (4) to the robot (1).  
⇒ Observe the tightening torque for the mounting screws.

Item	Mounting	SWK 007
5	ISO-Flange	ISO 9409-1-31.5-4-M5

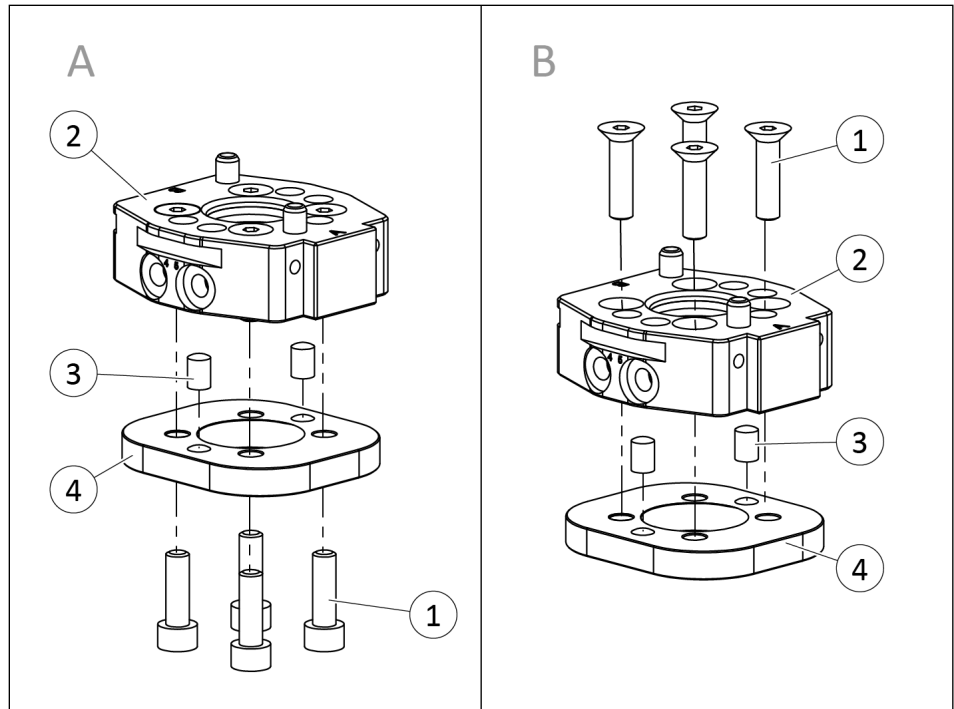

Mount adapter plate (shown as an example) to SWA 007 (A = mounting from below; B = mounting from above)

**NOTE**

If the axial pneumatic feed-throughs are to be used on SWA 007, observe chapter ▶ 5.3.4.1 [ 59].

1. Clean mounting patterns on SWA (2) and adapter plate (4).
2. Insert the adapter plate (4) with two dowel pins (3) or one dowel pin and a centering plate into the bores provided for this purpose.
3. Secure the adapter plate (4) to the SWA (2) from above or below with screws (1).
4. Mount the end effector.

## 5.2.4 SWS 011HM

### NOTE

Observe requirements when using an adapter plate, ▶ 5.2 [ 34]. Further information on the adapter plate design and precise manufacturing instructions can be found in the catalog data sheet, ▶ 1.1.3 [ 8].

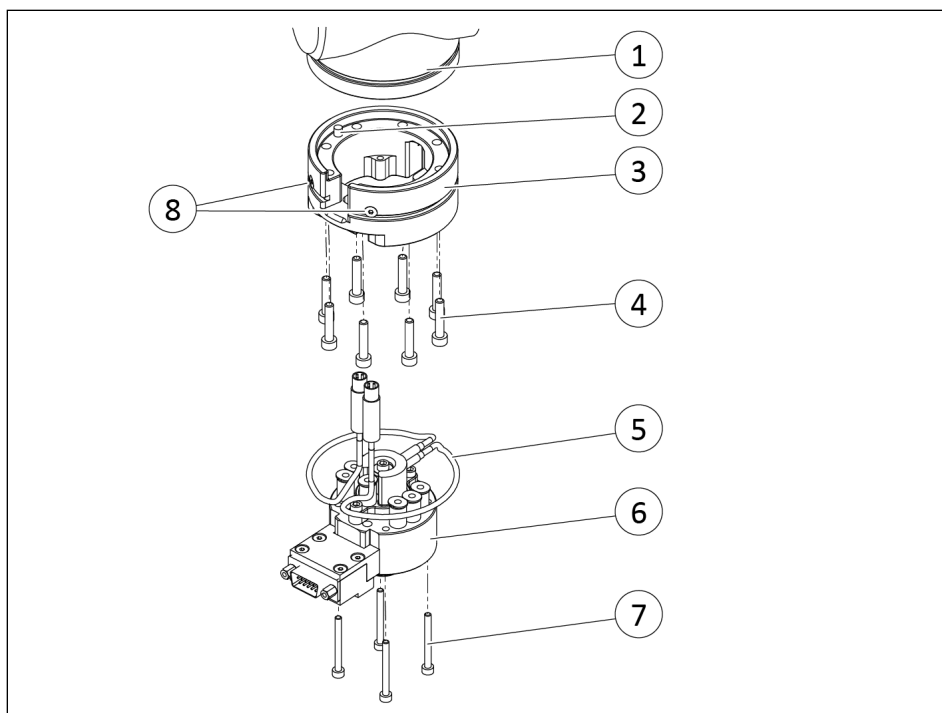

Mounting on robot for SWK 011HM

1. Clean the mounting patterns on the robot (1), adapter plate (3) and SWK (6).
2. Insert dowel pin (2) into adapter plate (3).
3. Apply screw lock to screws (4).
4. Insert the adapter plate (3) with dowel pin (2) into the bore on the robot.
5. Secure the adapter plate (3) to the robot (1) with screws (4).  
⇒ Observe the tightening torque for the mounting screws.
6. Guide the cable (5) along the adapter plate (3) in the direction of the robot (1).
7. Secure cable (5) with screws (8).
8. Insert dowel pin on SWK (6) into the bores on the adapter plate (3).
9. Apply screw lock to screws (7).
10. Fasten SWK (6) to adapter plate (3) with screws (7).  
⇒ Observe the tightening torque for the mounting screws.

Item	Mounting	SWK 011HM
7	Mounting screw according to standard	M3 x 30, DIN EN ISO 4762
	Strength class	12.9
	Max. tightening torque [Nm]	1.13
	Threadlocker	Loctite ® 222

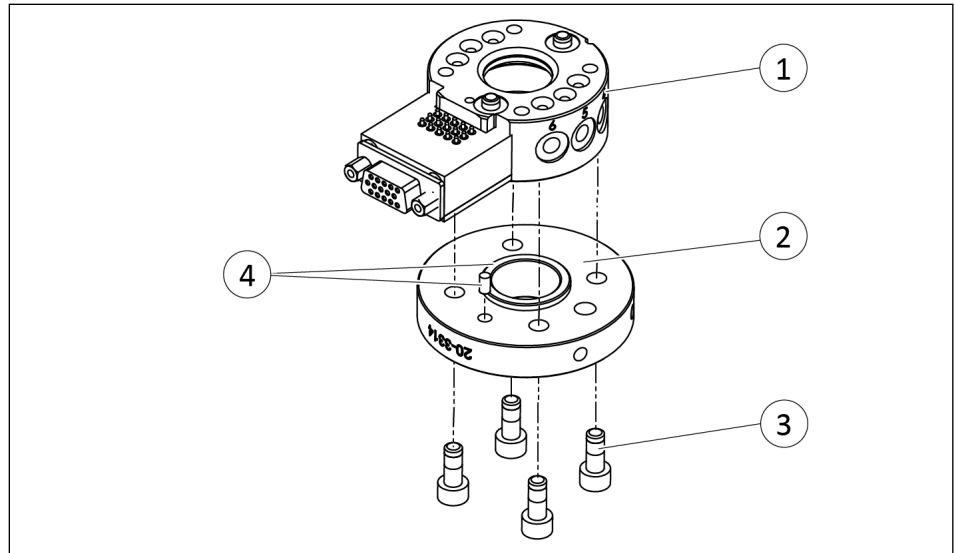

Mount adapter plate (shown as an example) to SWA 011

1. Clean mounting surfaces on SWA (1) and adapter plate (2).
2. Insert the adapter plate (2) with two alignment pins and/or with one alignment pin and the centering collar on the adapter plate (4) into the holes provided for this purpose.
3. Fasten the adapter plate (2) to the SWA (1) with screws (3).
4. Mount the end effector.

## 5.2.5 SWS 020 / 021 / 022 / 041 / 060

### NOTE

Observe requirements when using an adapter plate, ▶ 5.2 [ 34]. Further information on the adapter plate design and precise manufacturing instructions can be found in the catalog data sheet, ▶ 1.1.3 [ 8].

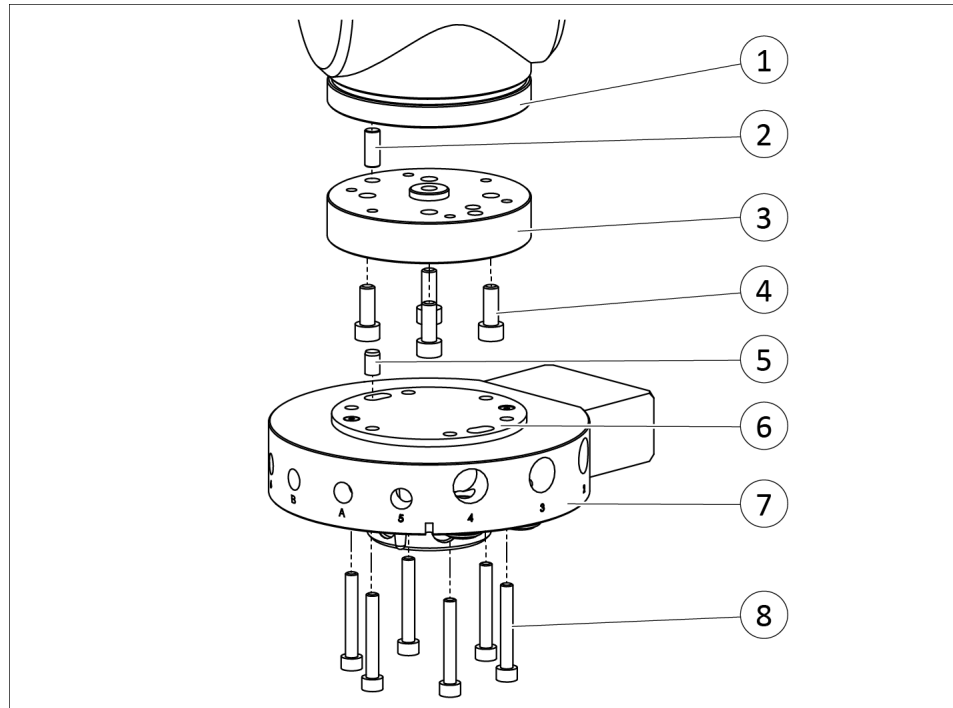

Mounting on robot shown as an example on SWK 041

1. Clean the mounting patterns on the robot (1), adapter plate (3) and SWK (7).
2. Insert dowel pin (2) into adapter plate (3).
3. Apply screw lock to screws (4).
4. Insert the adapter plate (3) with dowel pin (2) into the bore on the robot.
5. Secure the adapter plate (3) to the robot (1) with screws (4).  
⇒ Observe the tightening torque for the mounting screws.

### NOTE

Depending on the type of adapter plate (3), the SWK (7) is mounted on the adapter plate with or without the cover plate (6). If the adapter plate replaces the cover plate, the cover plate must be removed.

**6. In the event that the cover plate (6) has to be removed:**

Loosen screws (8) and remove cover plate (6) from the SWK (7).

**NOTICE! Product may leak! When removing the cover plate, ensure that the O-ring remains in the SWK**

**7.** Insert dowel pins (6) on the cover plate / SWK into the bores on the adapter plate.

**8.** Apply screw lock to screws (8).

**9.** Secure SWK (7) to adapter plate (3) with screws (8).

⇒ Observe the tightening torque for the mounting screws.

Item	Mounting	SWK 020	SWK 021	SWK 022	SWK 041	SWK 060
5	Alignment pin	Ø 4 x 14		Ø 6 x 16	Ø 6 x 20	
8	Mounting screw according to standard	M4 x 30	M4 x 35	M6 x 30	M5 x 40	M6 x 40
		DIN EN ISO 10642		DIN EN ISO 4762	DIN EN ISO 4762	DIN EN ISO 10642
	Strength class	10.9		12.9	8.8	10.9
	Max. tightening torque [Nm]	1.13		10.2	5.08	6.78
Threadlocker	Loctite ® 222		Loctite ® 242	Loctite ® 222	Loctite ® 242	

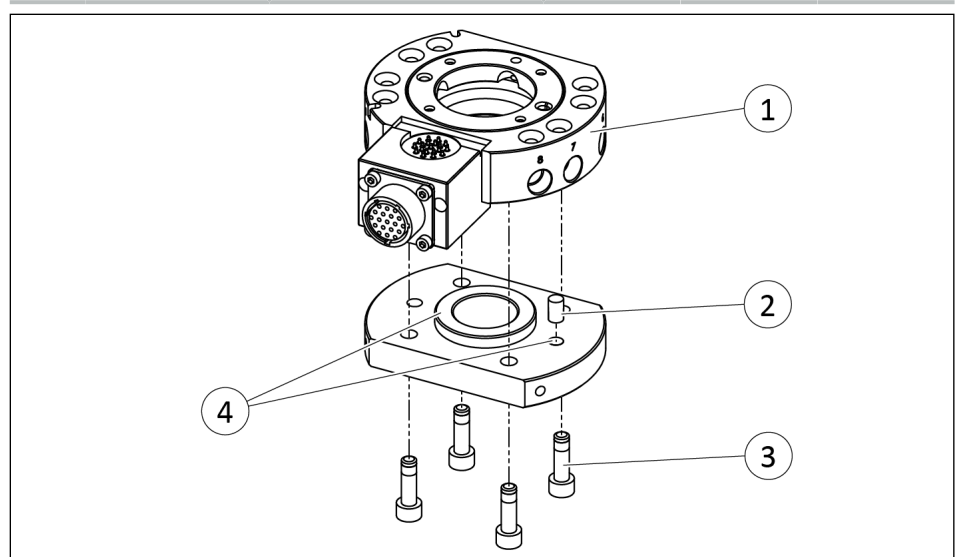

Mount adapter plate (shown as an example) to SWA, illustrated on SWA 021

**1.** Clean mounting surfaces on SWA (1) and adapter plate (2).

**2.** Insert the adapter plate (2) with two alignment pins and/or with one alignment pin and the centering collar on the adapter plate (4) into the holes provided for this purpose.

3. Fasten the adapter plate (2) to the SWA (1) with screws (3).
4. Mount the end effector.

### 5.2.6 SWS 020HM / 021HM

#### NOTE

Observe requirements when using an adapter plate, ▶ 5.2 [ 34]. Further information on the adapter plate design and precise manufacturing instructions can be found in the catalog data sheet, ▶ 1.1.3 [ 8].

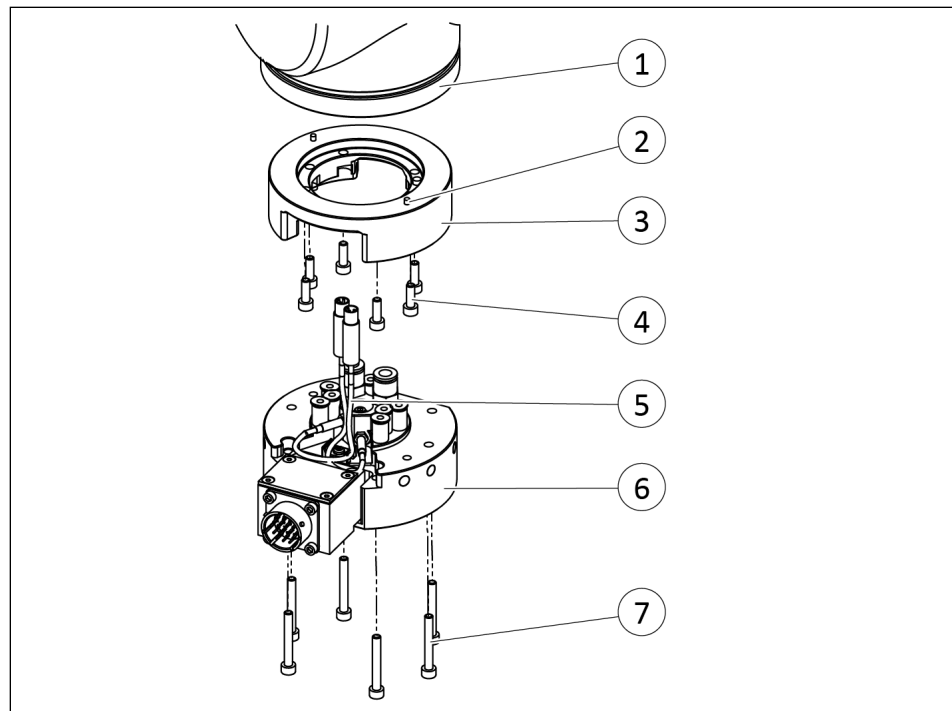

Mounting on robot shown as an example on SWK 021HM

1. Clean the mounting patterns on the robot (1), adapter plate (3) and SWK (6).
2. Insert dowel pins (2) into adapter plate (3).
3. Apply screw lock to screws (4).
4. Insert the adapter plate (3) with dowel pins (2) into the bores on the robot.
5. Secure the adapter plate (3) to the robot (1) with screws (4).  
⇒ Observe the tightening torque for the mounting screws.
6. Guide the cable (5) through the channel in the adapter plate (3) in the direction of the robot (1).
7. Insert dowel pin on SWK (6) into the bores on the adapter plate (3).
8. Apply screw lock to screws (7).
9. Fasten SWK (6) to adapter plate (3) with screws (7).  
⇒ Observe the tightening torque for the mounting screws.

Item	Mounting	SWK 020HM / 021HM
7	Mounting screw according to standard	M4 x 30, DIN EN ISO 4762
	Strength class	12.9
	Max. tightening torque [Nm]	1.69
	Threadlocker	Loctite ® 222

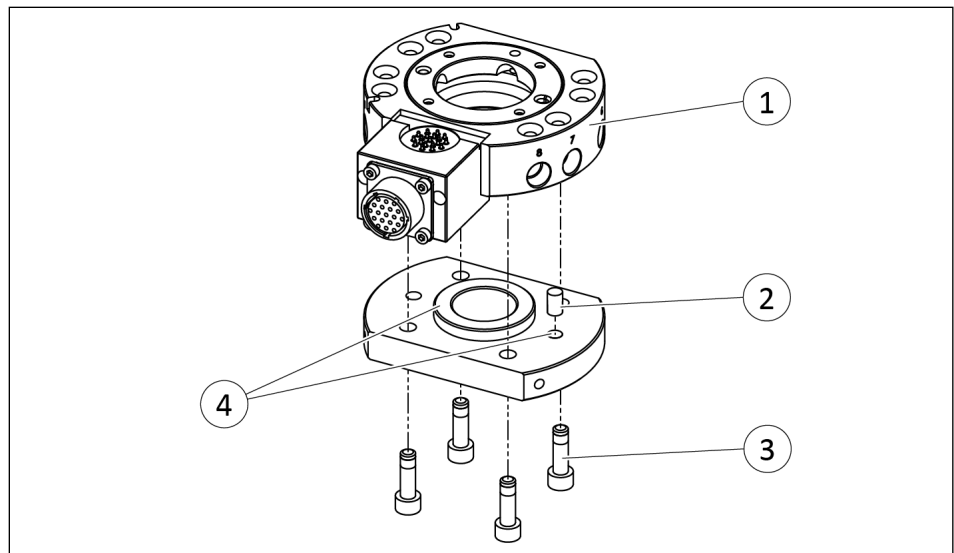

Mount adapter plate (shown as an example) to SWA, illustrated on SWA 021

1. Clean mounting surfaces on SWA (1) and adapter plate (2).
2. Insert the adapter plate (2) with two alignment pins and/or with one alignment pin and the centering collar on the adapter plate (4) into the holes provided for this purpose.
3. Fasten the adapter plate (2) to the SWA (1) with screws (3).
4. Mount the end effector.

### 5.2.7 SWS 029

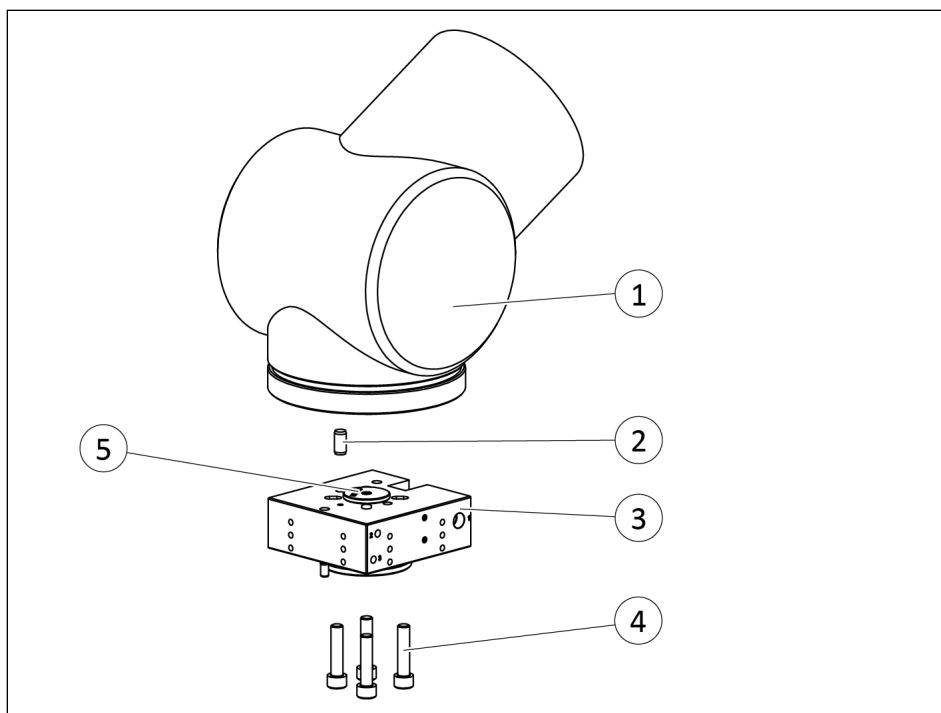

Mounting on robot for SWK 029

1. Clean the mounting surfaces on the robot (1) and SWK (3).
2. **For mounting on a robot without ISO flange interface:**  
Mount adapter plate between robot (1) and SWK (3).
3. Insert alignment pin (2) in SWK (3).
4. Apply screw lock to screws (4).
5. Align SWK with alignment pin (2) on robot and insert SWK (3) with centering collar (5) into the fitting bore on the robot (1).
6. Secure SWK (3) with screws (4) to the robot (1).  
⇒ Observe the tightening torque for the mounting screws.

Item	Mounting	SWK 029
2	Alignment pin	∅ 6 x 14
4	Mounting screw according to standard	M6 x 35 DIN EN ISO 4762
	Strength class	12.9
	Max. tightening torque [Nm]	15
	Threadlocker	Loctite ® 242

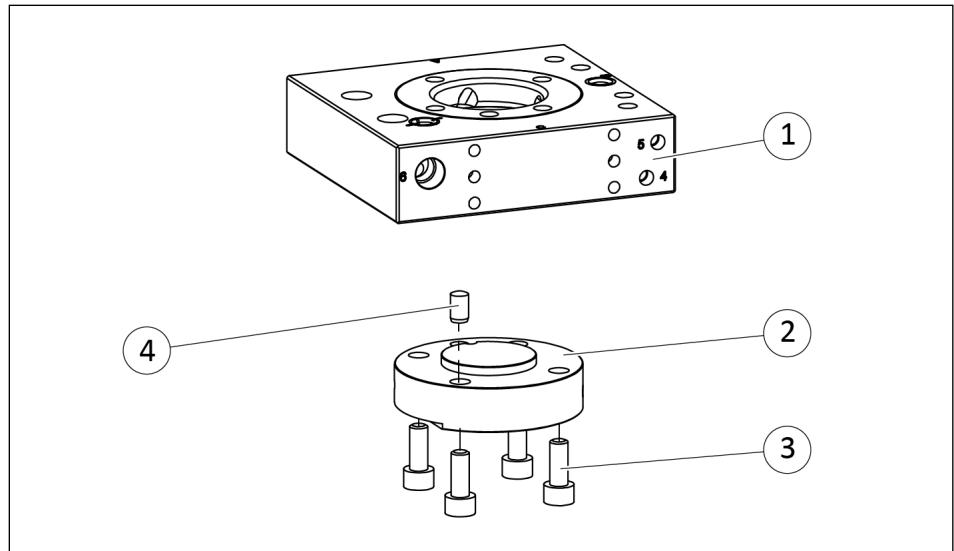

Mount adapter plate (shown as an example) to SWA 029

- 1.** Clean mounting surfaces on SWA (1) and adapter plate (2).
- 2.** Insert the adapter plate (2) with two alignment pins and/or with one alignment pin and the centering collar on the adapter plate (4) into the holes provided for this purpose.
- 3.** Fasten the adapter plate (2) to the SWA (1) with screws (3).
- 4.** Mount the end effector.

## 5.2.8 SWS 040Q / 071

### NOTE

Observe requirements when using an adapter plate, ▶ 5.2 [ 34]. Further information on the adapter plate design and precise manufacturing instructions can be found in the catalog data sheet, ▶ 1.1.3 [ 8].

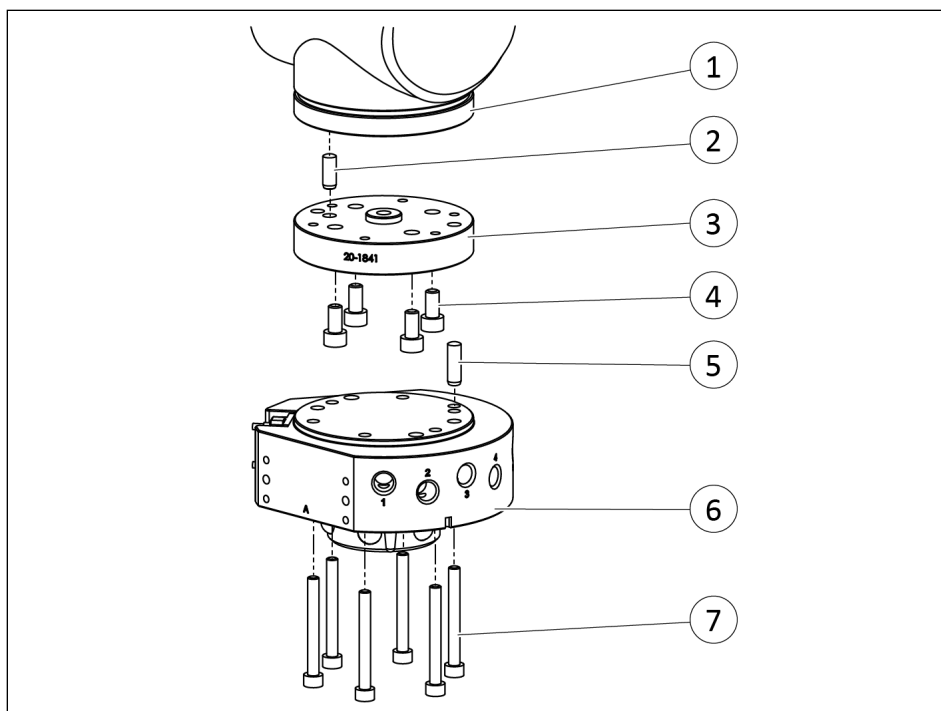

Mounting on robot for SWK 040Q

1. Clean the mounting patterns on the robot (1), adapter plate (3) and SWK (7).
2. Insert dowel pin (2) into adapter plate (3).
3. Apply screw lock to screws (4).
4. Insert the adapter plate (3) with dowel pin (2) into the bore on the robot.
5. Secure the adapter plate (3) to the robot (1) with screws (4).  
⇒ Observe the tightening torque for the mounting screws.
6. Insert dowel pins (5) into SWK (6).
7. Insert the SWK (6) with dowel pins (5) into the bores on the adapter plate.
8. Apply screw lock to screws (7).
9. Fasten SWK (6) to adapter plate (3) with screws (7).  
⇒ Observe the tightening torque for the mounting screws.

Item	Mounting	SWK 040Q
5	Alignment pin	∅ 6 x 20

Item	Mounting	SWK 040Q
7	Mounting screw according to standard	M5 x 45, DIN EN ISO 4762
	Strength class	12.9
	Max. tightening torque [Nm]	5.88
	Threadlocker	Loctite ® 242

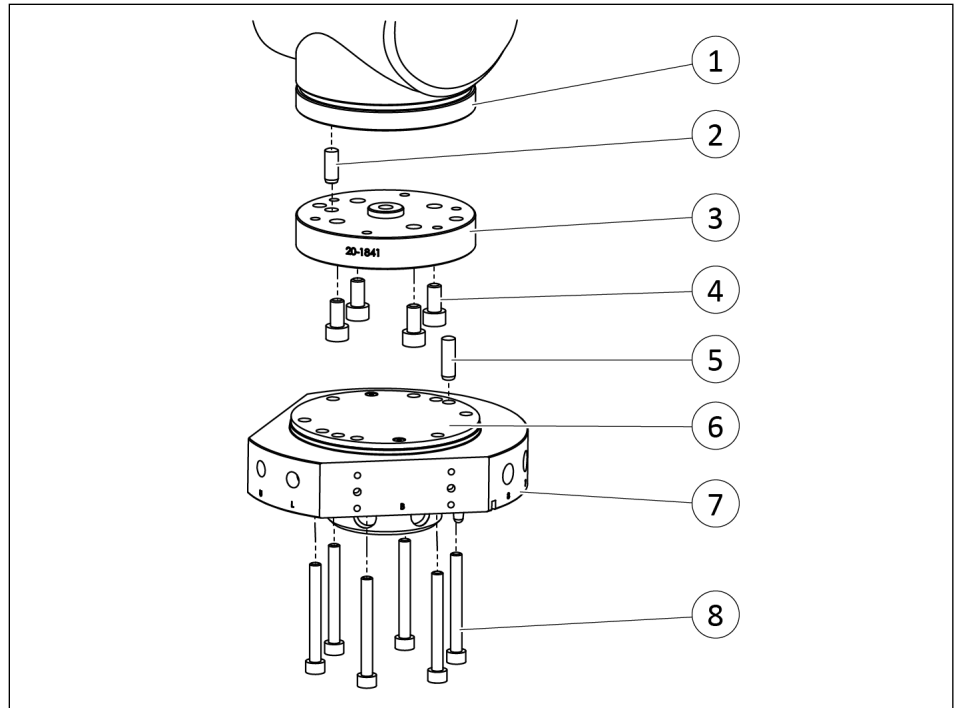

Mounting on robot for SWK 071

1. Clean the mounting patterns on the robot (1), adapter plate (3) and SWK (7).
2. Insert dowel pin (2) into adapter plate (3).
3. Apply screw lock to screws (4).
4. Insert the adapter plate (3) with dowel pin (2) into the bore on the robot.
5. Secure the adapter plate (3) to the robot (1) with screws (4).  
⇒ Observe the tightening torque for the mounting screws.

### NOTE

Depending on the type of adapter plate (3), the SWK (7) is mounted on the adapter plate with or without the cover plate (6). If the adapter plate replaces the cover plate, the cover plate must be removed.

**6. In the event that the cover plate (6) has to be removed:**

Loosen screws (8) and remove cover plate (6) from the SWK (7).

**NOTICE! Product may leak! When removing the cover plate, ensure that the O-ring remains in the SWK**

- 7. Insert dowel pins (5) into SWK (6).
- 8. Insert dowel pins (6) on the cover plate / SWK into the bores on the adapter plate.
- 9. Apply screw lock to screws (8).
- 10. Secure SWK (7) to adapter plate (3) with screws (8).

⇒ Observe the tightening torque for the mounting screws.

Item	Mounting	SWK 071
5	Alignment pin	∅ 6 x 20
8	Mounting screw according to standard	M6 x 40, DIN EN ISO 4762
	Strength class	8.8
	Max. tightening torque [Nm]	10.17
	Threadlocker	Loctite ® 242

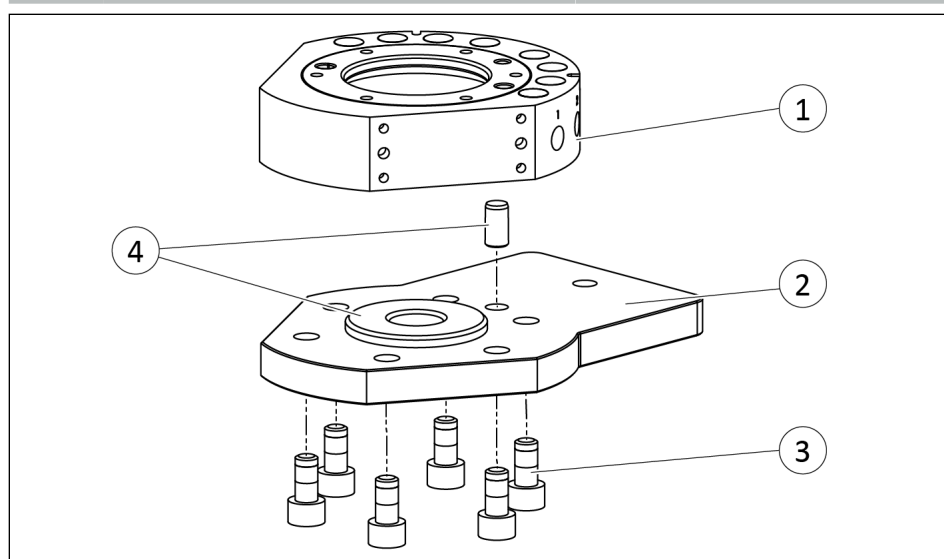

Mount adapter plate (shown as an example) to SWA, shown as an example on SWA 040Q

- 1. Clean mounting surfaces on SWA (1) and adapter plate (2).
- 2. Insert the adapter plate (2) with two alignment pins and/or with one alignment pin and the centering collar on the adapter plate (4) into the holes provided for this purpose.
- 3. Fasten the adapter plate (2) to the SWA (1) with screws (3).
- 4. Mount the end effector.

### 5.2.9 SWS 046

#### NOTE

The product in this size has an ISO flange as standard. When using a robot without ISO flange interface, the product can be mounted to the robot using an adapter plate.

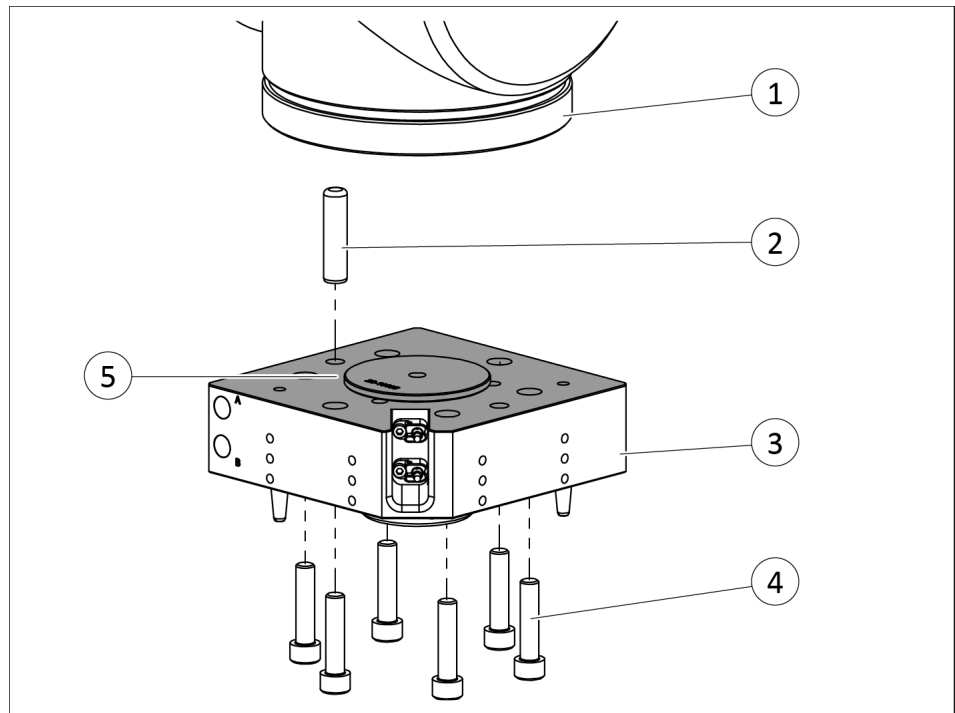

Mounting on robot for SWK 046

1. Clean the mounting surfaces on the robot (1) and SWK (3).
2. **For mounting on a robot without ISO flange interface:**  
Mount adapter plate between robot (1) and SWK (3).
3. Insert alignment pin (2) in SWK (3).
4. Apply screw lock to screws (4).
5. Align SWK with alignment pin (2) on robot and insert SWK (3) with centering collar (5) into the fitting bore on the robot (1).
6. Secure SWK (3) with screws (4) to the robot (1).  
⇒ Observe the tightening torque for the mounting screws.

Item	Mounting	SWK 046
5	ISO-Flange	ISO 9409-1-100-6-M8

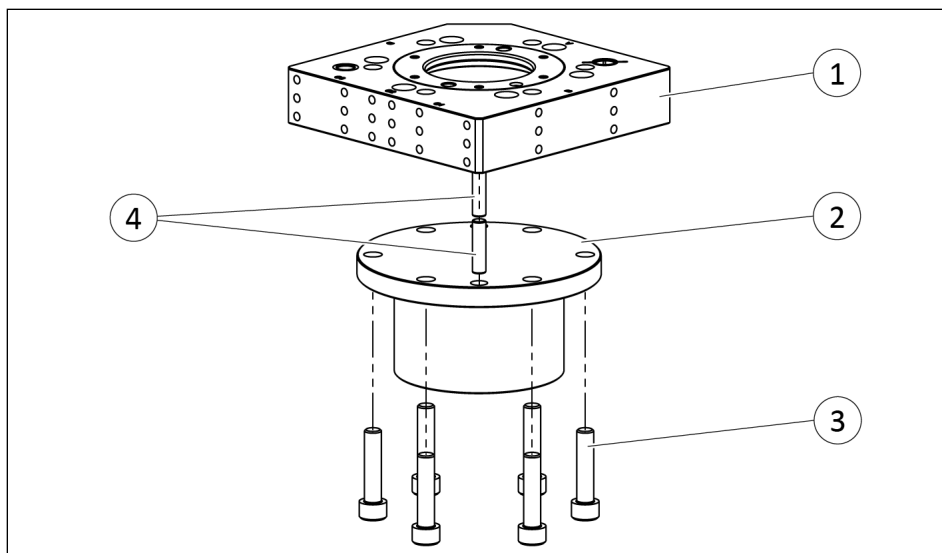

Mount adapter plate (shown as an example) to SWA 046

- 1.** Clean mounting surfaces on SWA (1) and adapter plate (2).
- 2.** Insert the adapter plate (2) with two alignment pins and/or with one alignment pin and the centering collar on the adapter plate (4) into the holes provided for this purpose.
- 3.** Fasten the adapter plate (2) to the SWA (1) with screws (3).
- 4.** Mount the end effector.

### 5.2.10 SWS 076 / 110 / 160

#### NOTE

The product in this size has an ISO flange as standard. When using a robot without ISO flange interface, the product can be mounted to the robot using an adapter plate.

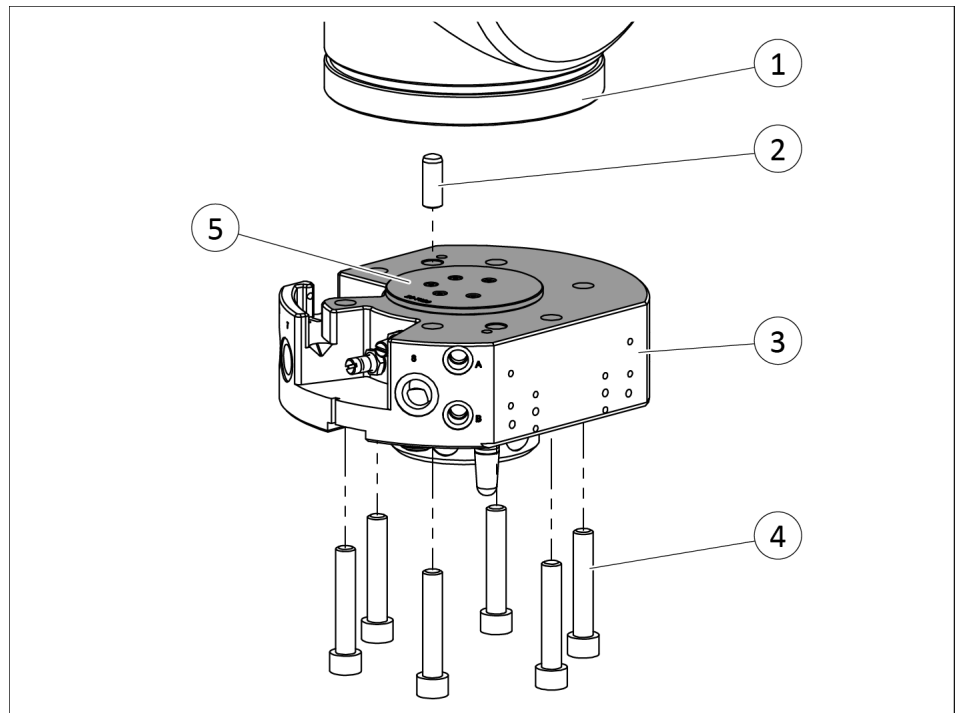

Mounting on robot shown as an example on SWK 110

1. Clean the mounting surfaces on the robot (1) and SWK (3).
2. **For mounting on a robot without ISO flange interface:**  
Mount adapter plate between robot (1) and SWK (3).
3. Insert alignment pin (2) in SWK (3).
4. Apply screw lock to screws (4).
5. Align SWK with alignment pin (2) on robot and insert SWK (3) with centering collar (5) into the fitting bore on the robot (1).
6. Secure SWK (3) with screws (4) to the robot (1).  
⇒ Observe the tightening torque for the mounting screws.

Item	Mounting	SWK 076	SWK 110	SWK 160
5	ISO-Flange	ISO 9409-1-125-6-M10		ISO 9409-1-125 -10-M10

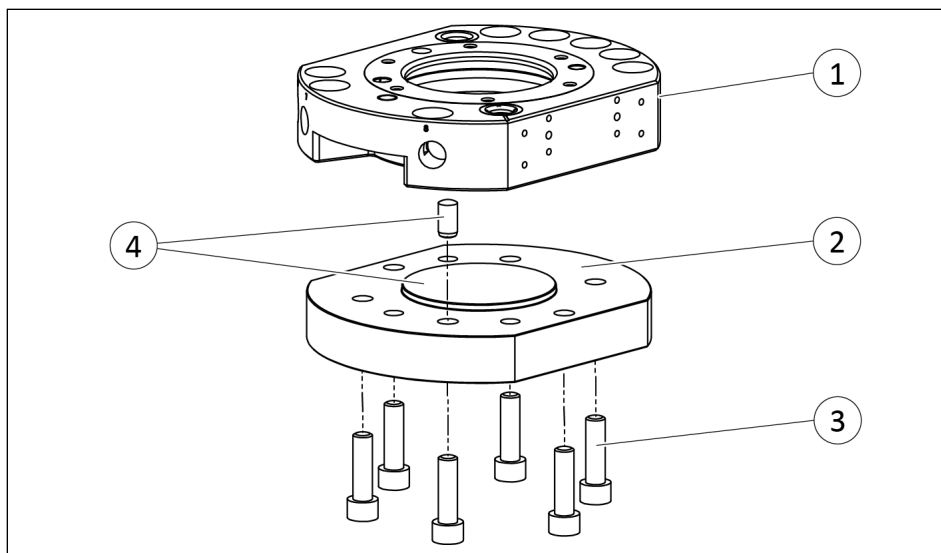

Mount adapter plate (shown as an example) to SWA, illustrated on SWA 110

- 1.** Clean mounting surfaces on SWA (1) and adapter plate (2).
- 2.** Insert the adapter plate (2) with two alignment pins and/or with one alignment pin and the centering collar on the adapter plate (4) into the holes provided for this purpose.
- 3.** Fasten the adapter plate (2) to the SWA (1) with screws (3).
- 4.** Mount the end effector.

### 5.3 Pneumatic connection

#### NOTICE

##### Material damage due to loss of compressed air!

The SWA can become loose in the event of a loss of compressed air, but the connection between SWK and SWA is ensured by a **patented self-locking** mechanism. The SWK can then no longer decouple a coupled SWA or accept a new SWA. A loss of compressed air leads to increased wear.

- End the fail-safe operation as soon as possible. To do this, restore the compressed air supply or stop operation of the machine/automated system to eliminate the cause of the failure.
- After a fail-safe operation, check the system for damage and monitor the resumption of normal operation for proper functioning.

#### NOTE

Observe the requirements for the compressed air supply, ▶ 3 [ 16].

#### 5.3.1 Example for pneumatic control

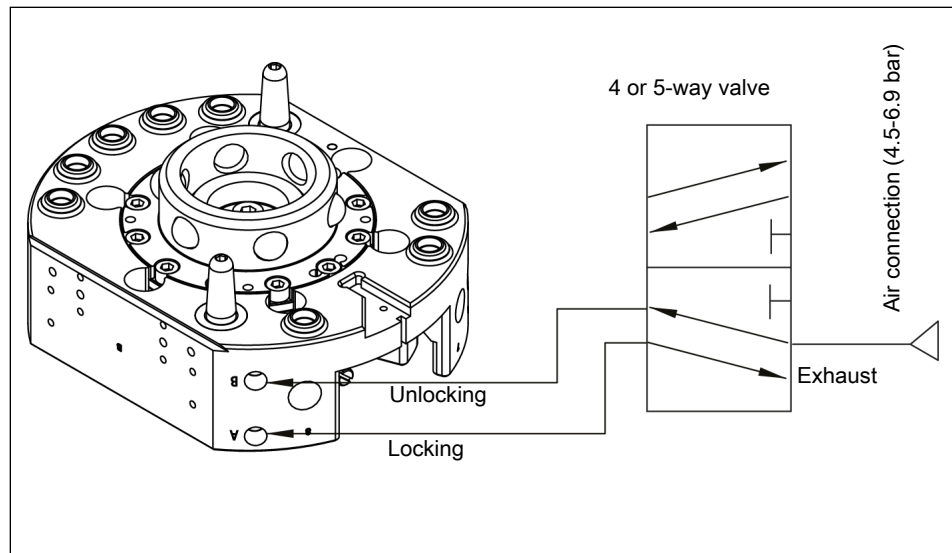

SWK, illustration unlocked, shown as an example on SWK 110

### 5.3.2 SWS 001

SWS	Pneumatic feed-throughs	Air supply lock and unlock
001	4x M5	M3

Tab.: Dimensions of the compressed air connections

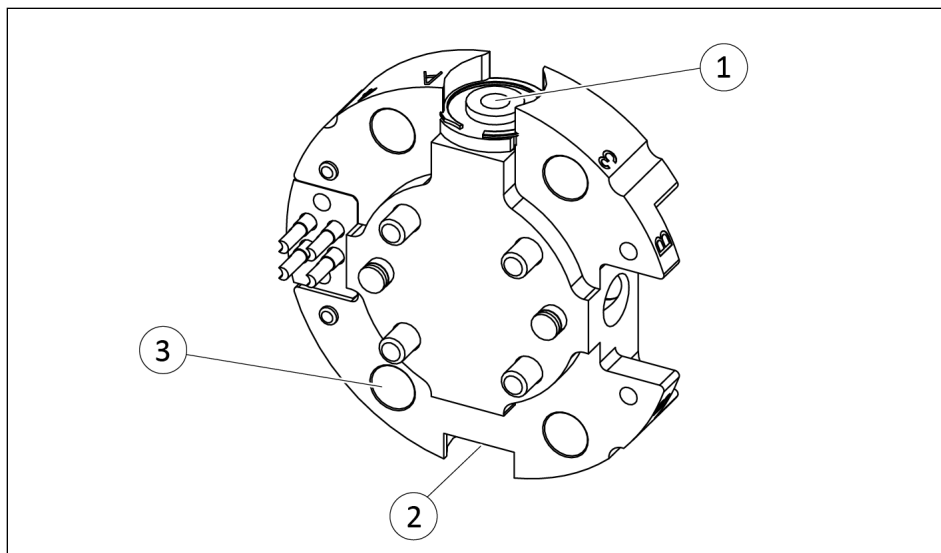

Pneumatic connection SWK 001

- 1 Air supply lock
- 2 Air supply unlock
- 3 Port for pneumatic feed-through

### 5.3.3 SWS 005

#### NOTICE

#### Damage to the product due to lack of compensation possible!

The piston of the SWK 005 moves in the opposite direction when unlocked, i.e. in the direction of the SWA. The end effector is actively repelled with the aid of the release bolt in the SWA. If there is no possibility for displacement due to the tool rack or the robot, the product can wear out faster or become damaged beyond repair after a short time.

- Ensure sufficient compensation in the direction of the release bolt, which compensates for the separation of SWK and SWA.
  - ⇒ Min. distance when locking [mm]: 1.5
  - ⇒ Max. distance when locking [mm]: 3

SWS	Pneumatic feed-throughs	Air supply lock and unlock
005	6x M5	M5

Tab.: Dimensions of the compressed air connections

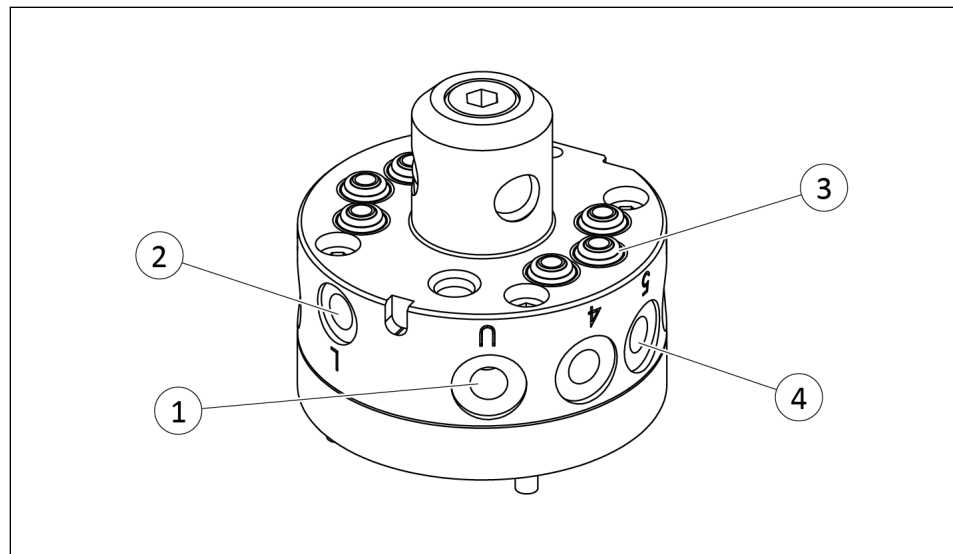

Pneumatic connection SWK 005

- |   |                                            |
|---|--------------------------------------------|
| 1 | Air supply unlock                          |
| 2 | Air supply lock                            |
| 3 | Pneumatic feed-through with rubber bushing |
| 4 | Port for pneumatic feed-through            |

### 5.3.4 SWS 007

SWS	Pneumatic feed-throughs	Air supply lock and unlock
007	5x M5	M5

Tab.: Dimensions of the compressed air connections

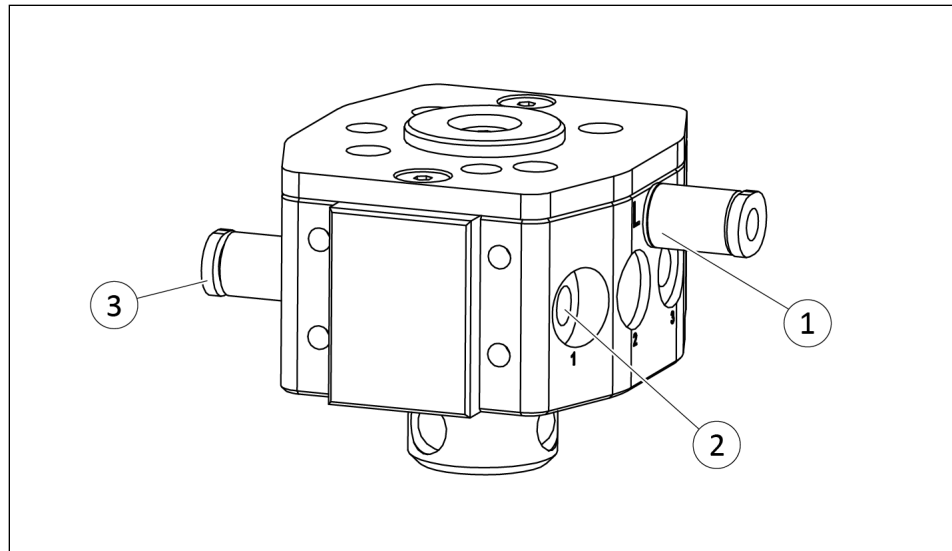

*Pneumatic connection SWK 007*

- 1 Air supply lock with pneumatic screw connection \*
- 2 Port for pneumatic feed-through
- 3 Air supply unlock with pneumatic screw connection \*

\* contained in accessory kit

#### 5.3.4.1 Axial pneumatic feed-throughs

The SWA 007 has axial ports for pneumatic feed-through, which can optionally be used instead of the radial connections.

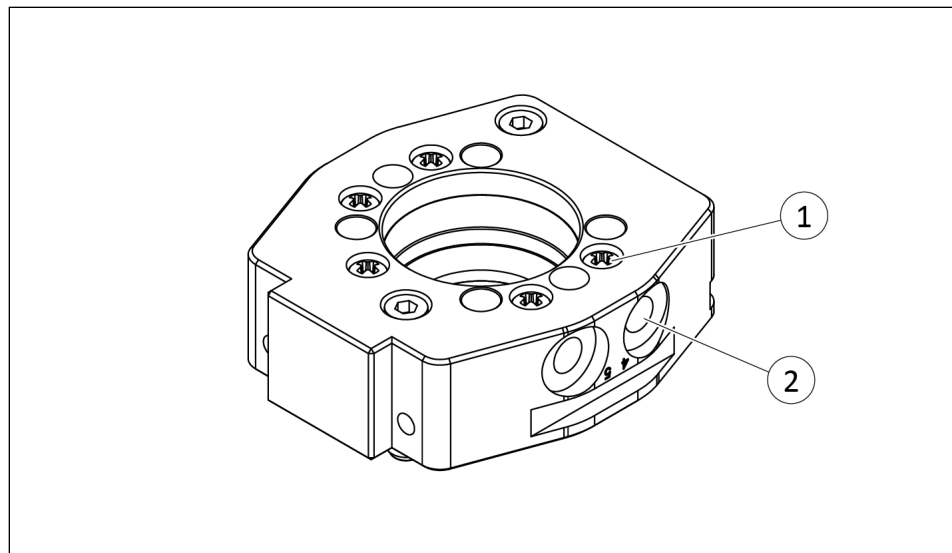

*Axial pneumatic feed-throughs on SWA 007*

- 1 Axial port for pneumatic feed-through
  - 2 Radial port for pneumatic feed-through
1. Remove screws on the bottom of the SWA from the axial ports for pneumatic feed-through (1).
  2. Seal the axial ports for pneumatic feed-through (1) with O-rings from the accessory kit.

- 
- 
- 3.** Close the radial ports for pneumatic feed-through (2) with plugs.

### 5.3.5 SWS 011

SWS	Pneumatic feed-throughs	Air supply lock and unlock
011	6x M5	M5

Tab.: Dimensions of the compressed air connections

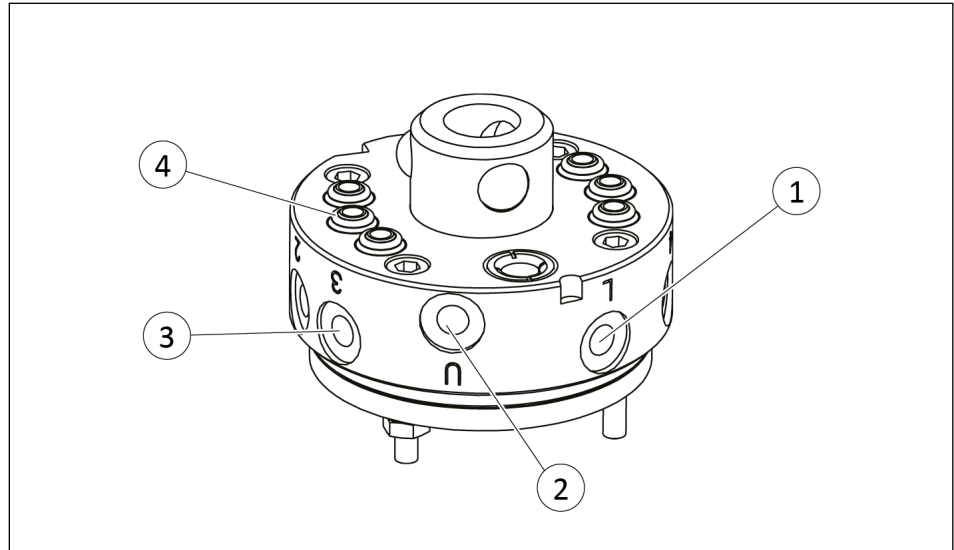

Pneumatic connection SWK 011

- |   |                                            |
|---|--------------------------------------------|
| 1 | Air supply lock                            |
| 2 | Air supply unlock                          |
| 3 | Port for pneumatic feed-through            |
| 4 | Pneumatic feed-through with rubber bushing |

### 5.3.6 SWS 011HM

SWS	Pneumatic feed-throughs	Air supply lock and unlock
011HM	6x G1/8"	G1/8"

Tab.: Dimensions of the compressed air connections

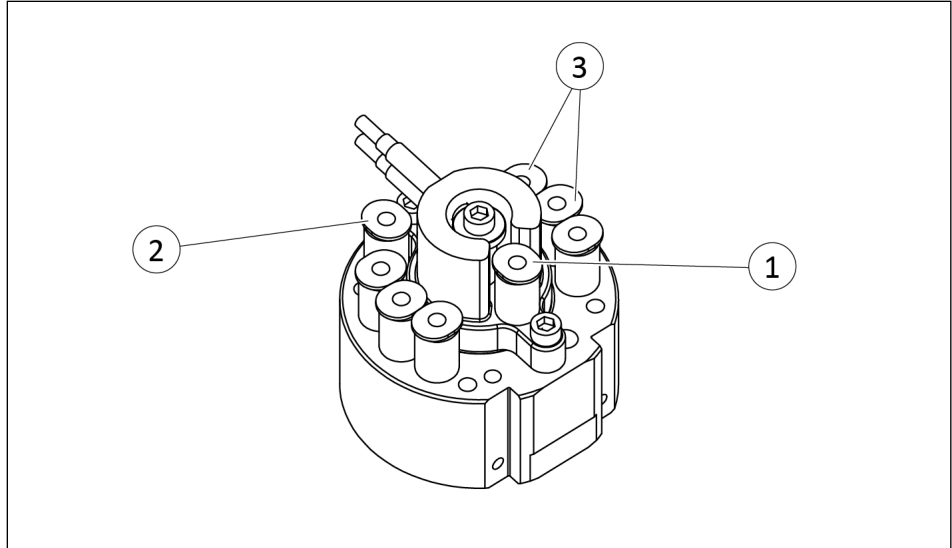

Pneumatic connection SWK 011HM

- 1 Air supply lock with pneumatic screw connection
- 2 Air supply unlock with pneumatic screw connection
- 3 Port for pneumatic feed-through with pneumatic screw connection

### 5.3.7 SWS 020 / 021 / 041 / 060

SWS	Pneumatic feed-throughs	Air supply lock and unlock
020	12x M5	M5
021	8x G1/8"	M5
041	6x G3/8", 4x G1/8"	G1/8"
060	8x G1/8"	G1/8"

Tab.: Dimensions of the compressed air connections

#### NOTE

The rubber bushings are located at the SWS 020 in SWA and not, as shown here, in SWK.

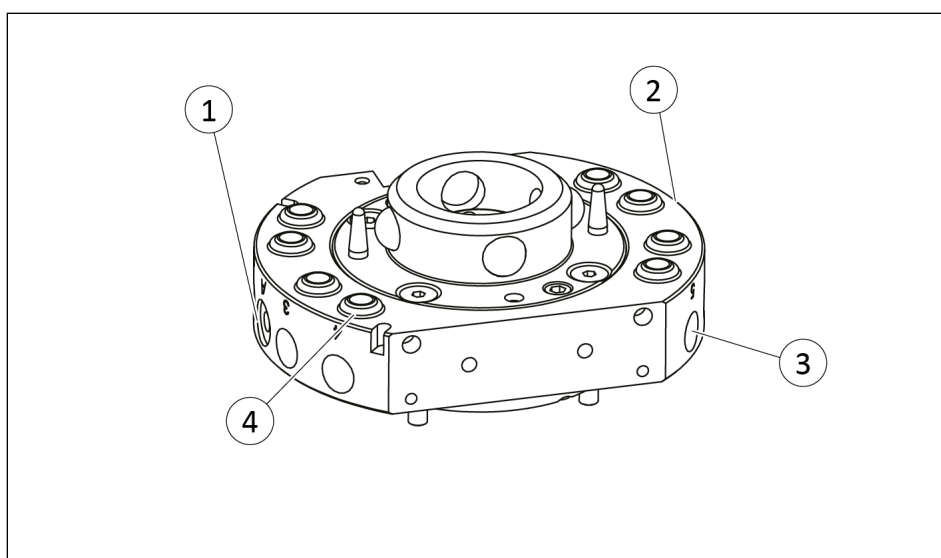

Pneumatic connection, shown as an example on SWK 021

- 1 Air supply lock
- 2 Air supply unlock
- 3 Port for pneumatic feed-through
- 4 Pneumatic feed-through with rubber bushing

### 5.3.8 SWS 020HM / 021HM

SWS	Pneumatic feed-throughs	Air supply lock and unlock
020HM	12x G1/8"	G1/8"
021HM	6x G1/8", 2x G1/4"	G1/8"

Tab.: Dimensions of the compressed air connections

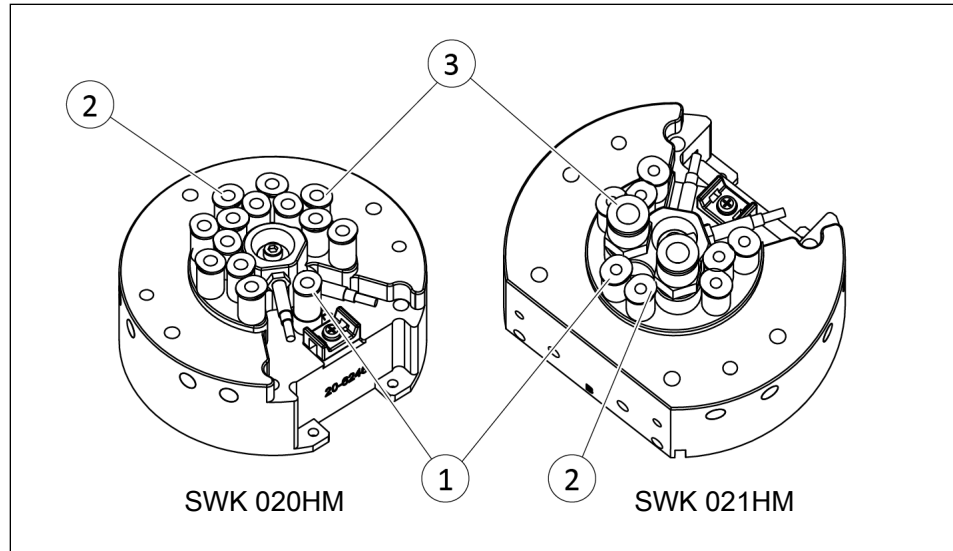

Pneumatic connection SWS 020HM / 021HM

- 1 Air supply lock with pneumatic screw connection
- 2 Air supply unlock with pneumatic screw connection
- 3 Port for pneumatic feed-through with pneumatic screw connection

### 5.3.9 SWS 022

SWS	Pneumatic feed-throughs	Air supply lock and unlock
022	6x G3/8"	M5

Tab.: Dimensions of the compressed air connections

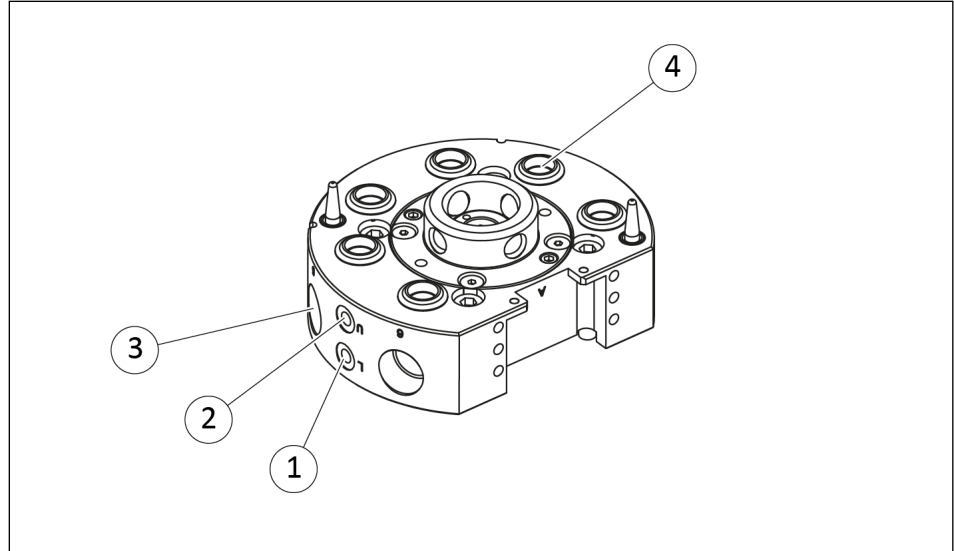

Pneumatic connection, shown as an example on SWK 022

- 1 Air supply lock

---

- 2 Air supply unlock

---

- 3 Port for pneumatic feed-through

---

- 4 Pneumatic feed-through with rubber bushing

---

### 5.3.10 SWS 029

SWS	Pneumatic feed-throughs	Air supply lock and unlock
29	2x G1/8", 4x M5	M5

Tab.: Dimensions of the compressed air connections

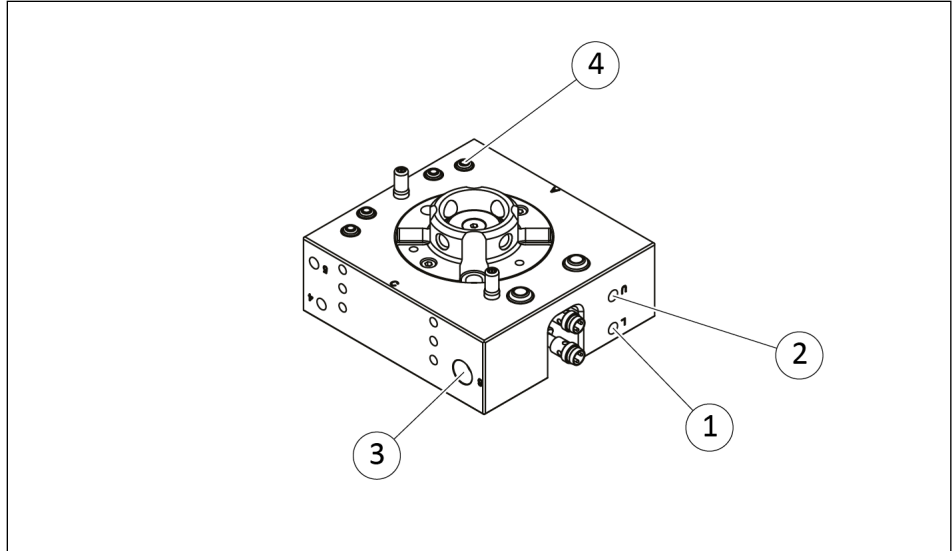

Pneumatic connection, shown as an example on SWK 029

- |   |                                            |
|---|--------------------------------------------|
| 1 | Air supply lock                            |
| 2 | Air supply unlock                          |
| 3 | Port for pneumatic feed-through            |
| 4 | Pneumatic feed-through with rubber bushing |

### 5.3.11 SWS 040Q / 071

SWS	Pneumatic feed-throughs	Air supply lock and unlock
040Q	8x G1/8"	G1/8"
071	8x G1/4"	G1/8"

Tab.: Dimensions of the compressed air connections

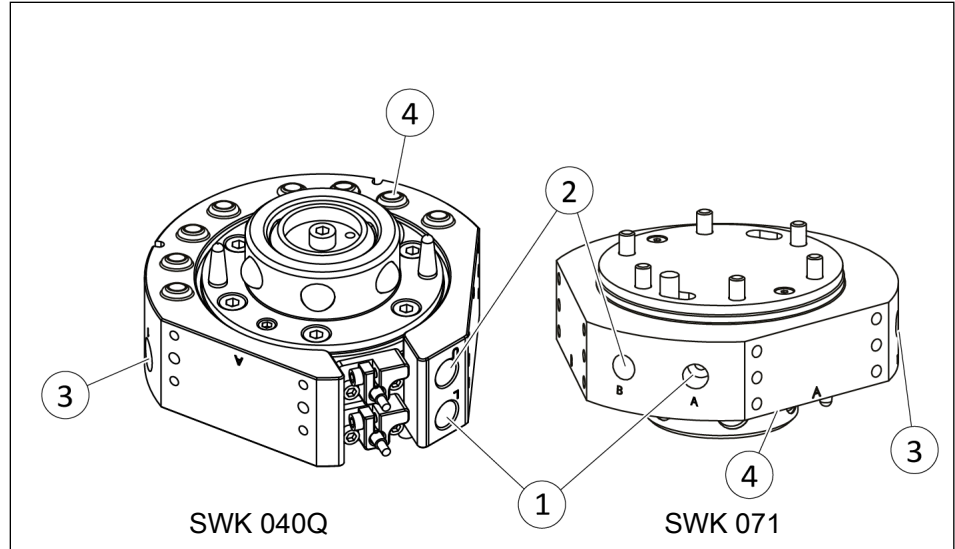

Pneumatic connection SWK 040Q / 071

- 1 Air supply lock
- 2 Air supply unlock
- 3 Port for pneumatic feed-through

### 5.3.12 SWS 046

SWS	Pneumatic feed-throughs	Air supply lock and unlock
046	– *	G1/8"

Tab.: Dimensions of the compressed air connections

\* Pneumatic feed-through possible with optional modules

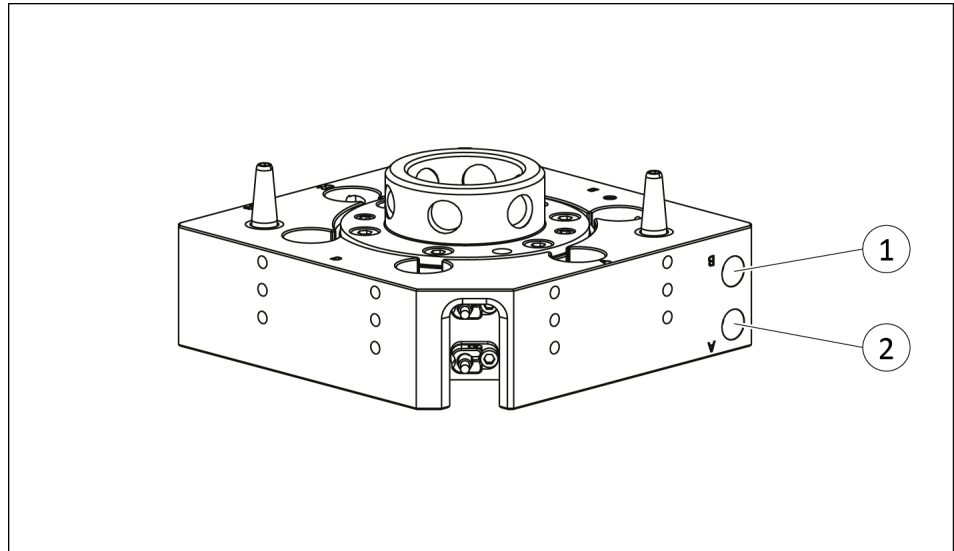

Pneumatic connection SWK 046

- 1 Air supply unlock
- 2 Air supply lock

### 5.3.13 SWS 076 / 110 / 160

SWS	Pneumatic feed-throughs	Air supply lock and unlock
076	5x G3/8"	G1/8"
110	8x G3/8"	G1/8"
160	5x G3/8", 4x G1/2"	G1/8"

Tab.: Dimensions of the compressed air connections

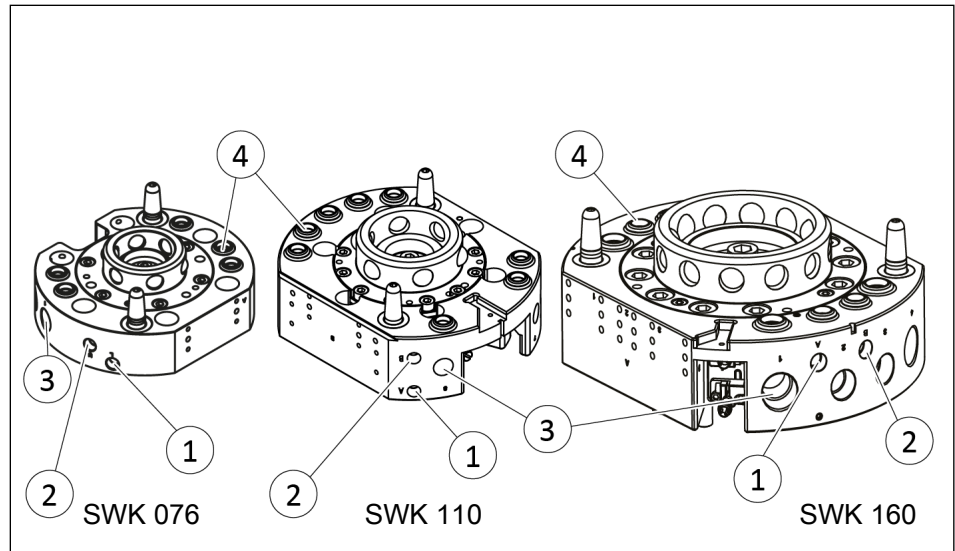

Pneumatic connection SWK 076 / 110 / 160

- 1 Air supply lock
- 2 Air supply unlock
- 3 Port for pneumatic feed-through
- 4 Pneumatic feed-through with rubber bushing

## 5.4 Mounting the sensor

The product is equipped for the use of sensors.

- For the exact type designations of suitable sensors, please see catalog datasheet and ▶ 5.4.1 [📄 70].
- For technical data for the suitable sensors, see Assembly and Operating Manual and catalog datasheet – which can be found at schunk.com.
- Information on handling sensors is available at schunk.com or from SCHUNK contact persons.

### 5.4.1 Overview of sensors

The piston stroke control checks whether the locking mechanism is locked or unlocked. Depending on the size, the piston stroke control is integrated or can be mounted externally.

The presence monitoring of the SWA checks whether SWK and SWA are coupled or not. A sensor is attached to the SWK for this purpose. A presence signal is transmitted on contact with the sensor target integrated in the SWA.

SWS	Piston stroke control		Presence monitoring of the SWA
	integrated	external	
001		-	
005		-	
007	X		
011		X	
011HM	X		
020		X	
020HM	X		
021		X	
021HM	X		
022	X		
029	X		
040Q	X		
041		X	
046	X		
060		X	
071		X	
076	X		X
110	X		X
160	X		X

The catalog data sheet contains more information.

## 5.4.2 Check integrated piston stroke control



### ⚠ CAUTION

#### Risk of injury from objects flying out!

Do not apply compressed air to the compressed air connections during assembly of the piston stroke control, as parts may come loose or the adapter plate or the O-ring may be damaged.

- Only apply compressed air to the pneumatic connection when the SWK is mounted on the robot.

### NOTICE

#### The sensor adjustment can be lost!

Do not move or remove sensors from the sensor assembly. The sensors are preset at the factory.

### NOTE

The sizes SWS 007, SWS 011HM, SWS 020HM, SWS 021HM, SWS 022, SWS 029, SWS 040Q, SWS 046, SWS 076, SWS 110 and SWS 160 can be equipped with an integrated piston stroke control.

If the integrated piston stroke control is required later for these sizes, the piston stroke control can be retrofitted. For more information, please contact SCHUNK.

SWS

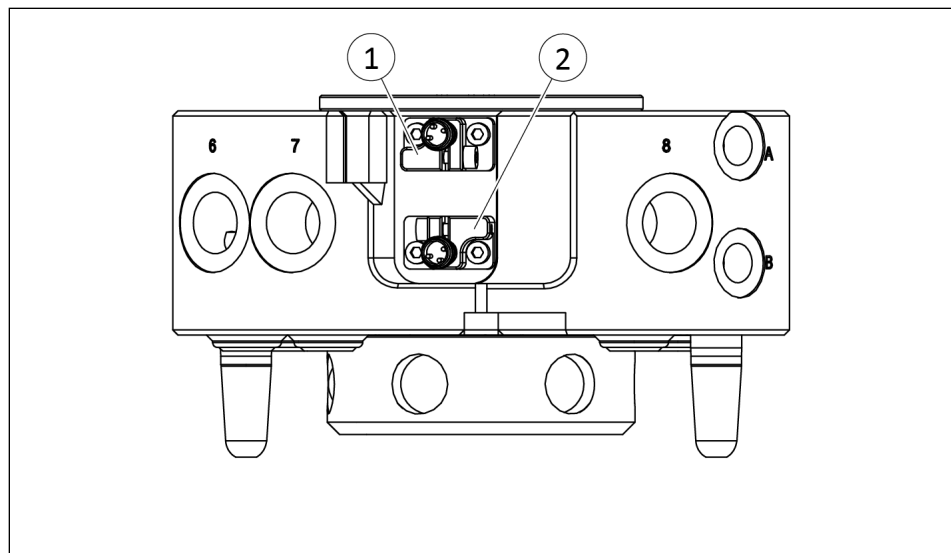

*Integrated piston stroke control shown as an example on SWK 160*

- Sensors for unlocking (1) and locking (2) monitoring are mounted and preset at the factory.
  - **In case of retrofitting:** Mount and check sensors, ▶ 7.8 [101]
1. Connect the sensor cable to the robot control system.

2. Switch on energy supply.
3. Lock and unlock the locking piston and check the signals of the sensors.

**SWS for hollow wrist robots**

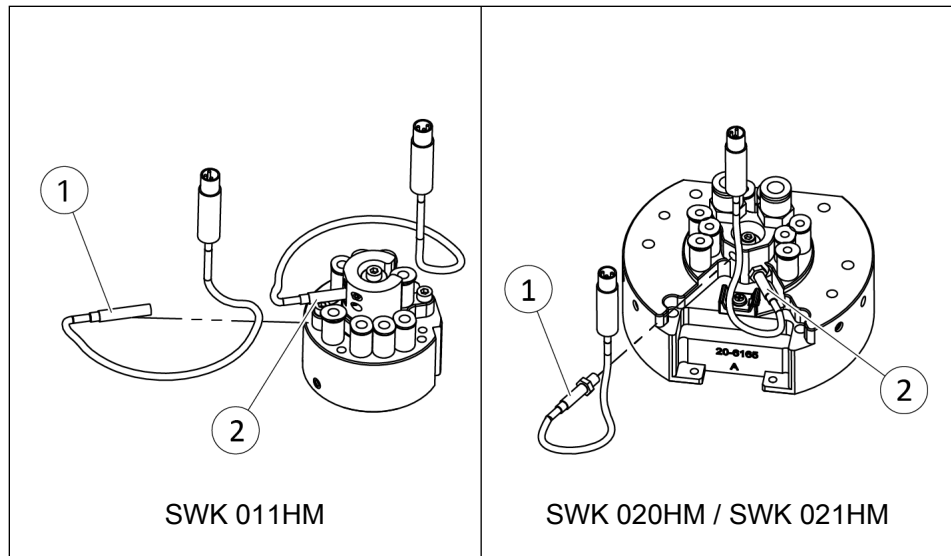

*Integrated piston stroke control for hollow wrist robots*

- Sensors for unlocking (1) and locking (2) monitoring are mounted and preset at the factory.
  - **In case of retrofitting:** Mount and check sensors, ▶ 7.8 [ 101 ]
1. Connect the sensor cable to the robot control system.
  2. Switch on energy supply.
  3. Lock and unlock the locking piston and check the signals of the sensors.

### 5.4.3 Mount and check external piston stroke control

#### NOTICE

##### The sensor adjustment can be lost!

Do not move or remove sensors from the sensor assembly. The sensors are preset at the factory.

#### NOTE

For the sizes SWS 011, SWS 020, SWS 021, SWS 041, SWS 060 and SWS 071, an external piston stroke control can be attached to the SWK.

#### NOTE

Observe requirements when using an adapter plate, ▶ 5.2 [ 34]. Further information on the adapter plate design and precise manufacturing instructions can be found in the catalog data sheet, ▶ 1.1.3 [ 8].

#### 5.4.3.1 SWS 011 / 020 / 021

##### Prepare sensor installation

1. Place the SWA in the storage rack, secure and uncouple it.
2. Switch off the power supply and ensure that there is no residual energy in the system.
3. Remove the compressed air hose.
4. Disassemble the SWK from the robot and safely set the SWK aside, ▶ 7.4 [ 89].

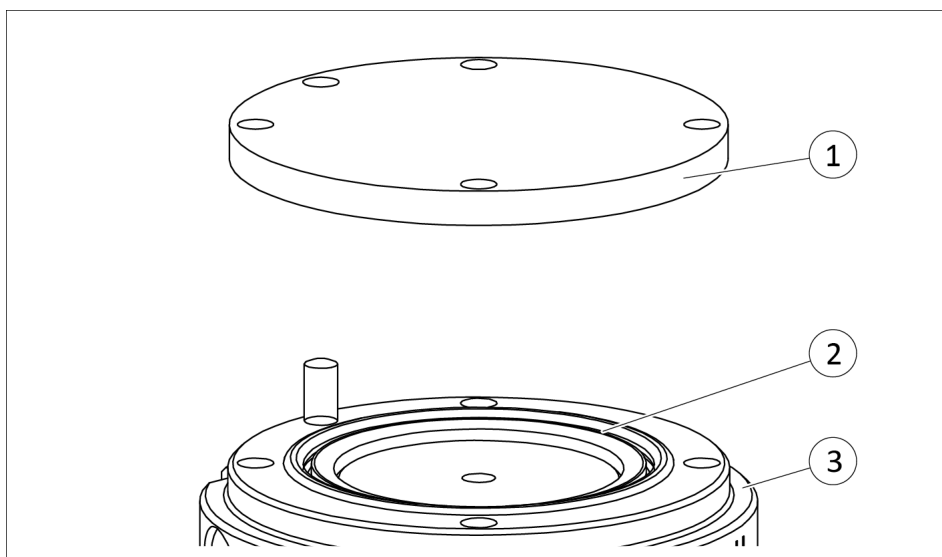

Remove cover plate

5. Carefully remove the cover plate (1) from the SWK (3). Make sure that the O-ring (2) remains in the SWK (3).

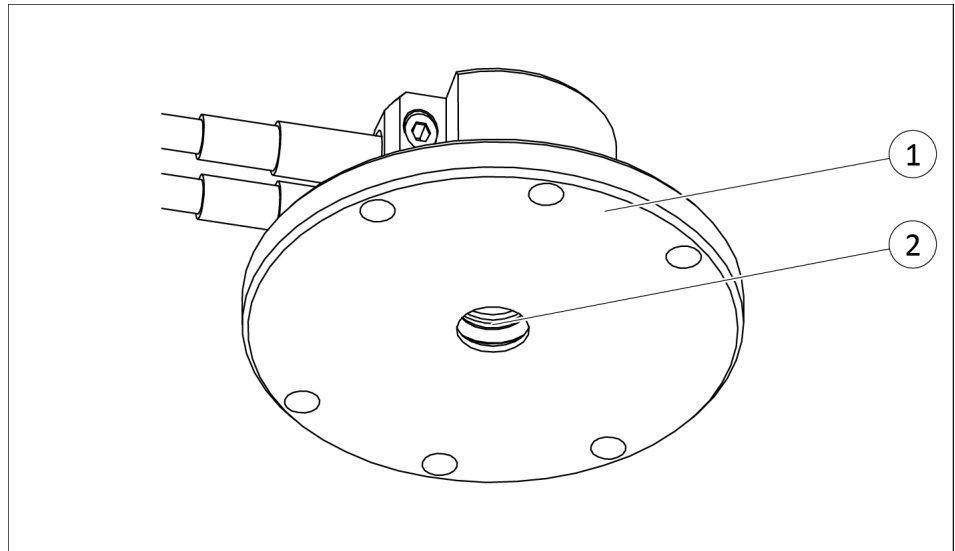

Prepare sensor assembly

6. Check the O-ring (2) in the sensor assembly (1) and lubricate if necessary, ▶ 7.3 [ 88].

**Mount sensor assembly on SWK**

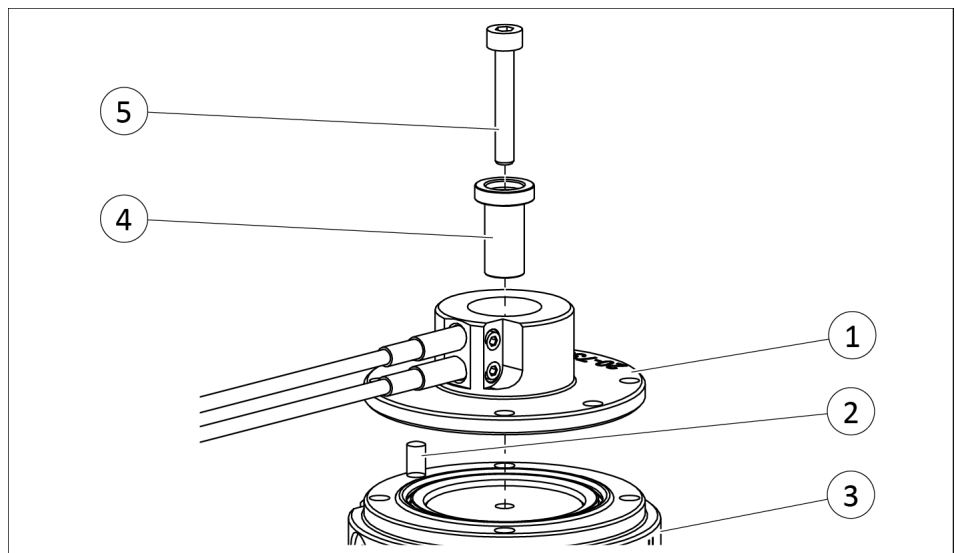

Mount sensor assembly on SWK

1. Push the sleeve for detection shaft (4) into the sensor assembly (1) up to the stop.
2. Apply the primer for the screw lock to the detection shaft (5) and briefly allow it to dry.
3. Apply screw lock to detection shaft (5).
4. Carefully push the detection shaft (5) into the sensor assembly (1) up to the stop.
5. Align the sensor assembly (1) with the dowel pin (2) on the SWK (3).

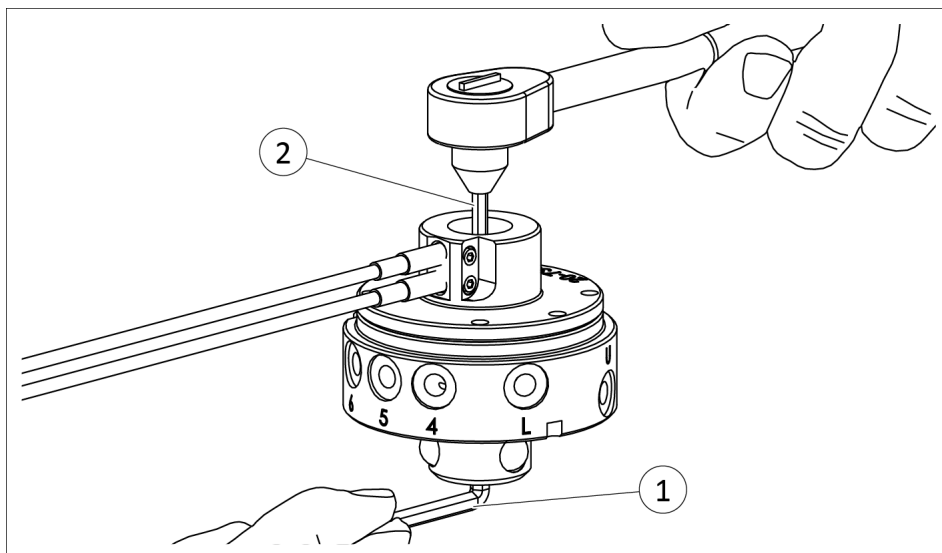

*Tighten the detection shaft*

- 6.** Fix the cam of the SWK with a hexagonal socket wrench (1) and tighten the detection shaft from above with a hexagonal socket wrench (2).

⇒ Max. tightening torque: 1.36 Nm

### Check and adjust sensors

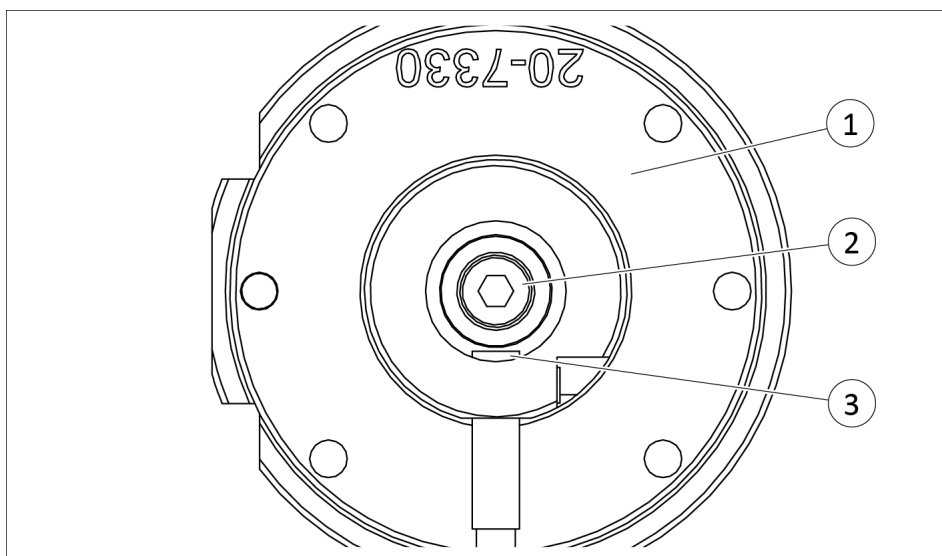

*Check detection shafts and sensors*

- 1.** Look at the sensor assembly from above.
- 2.** Make sure that the detection shaft and sensors are not touching each other, readjust the distance if necessary.
- 3.** Connect the sensor cable to the robot control system.
- 4.** Connect all compressed air lines.
- 5.** Switch on energy supply.
- 6.** Lock and unlock the locking piston and check the signals of the sensors.

### Mount SWK with sensor assembly to the robot

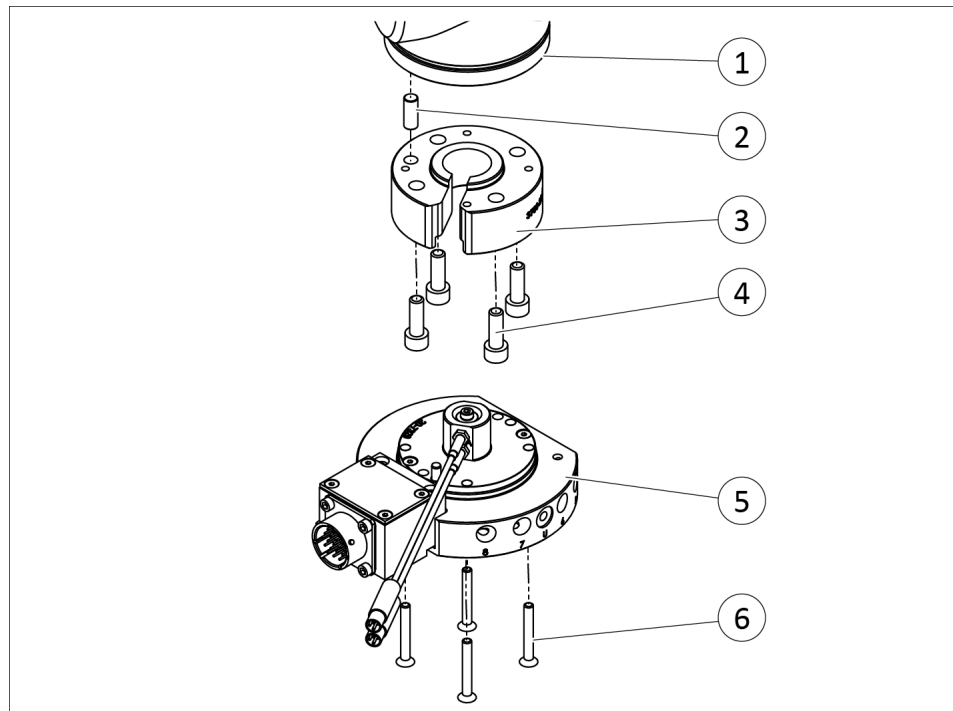

Mount SWK with adapter plate on the robot

1. Mount the adapter plate for the sensor assembly (3) to the robot (1) with the dowel pin (2) and screws (4).
  - ⇒ The dowel pin and screws depend on the robot and are not included in the scope of delivery.
2. Mount the SWK (5) to the adapter plate for sensor assembly (3) with screws (6).
  - ⇒ Observe the wrench size of the hexagon socket wrench and the max. tightening torque of the mounting screws for each size, see table "Mounting the SWK to the adapter plate for sensor assembly", ▶ 5.4.5 [ 83].
  - ⇒ SWK can be used with an external piston stroke control.

#### 5.4.3.2 SWS 041 / 060 / 071

##### Prepare sensor installation

1. Place the SWA in the storage rack, secure and uncouple it.
2. Switch off the power supply and ensure that there is no residual energy in the system.
3. Remove the compressed air hose.
4. Disassemble the SWK from the robot and safely set the SWK aside, ▶ 7.4 [ 89].

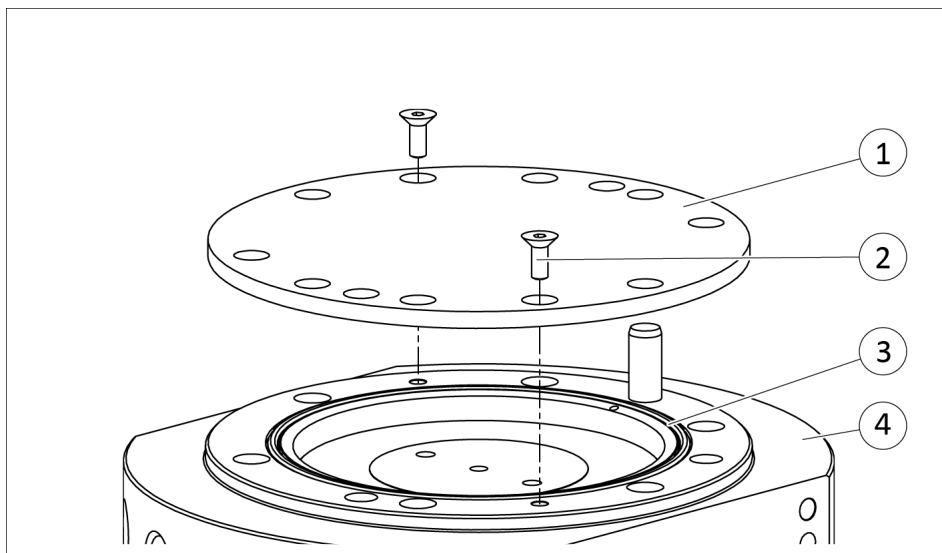

*Remove cover plate*

- 5.** Loosen screws (2) and carefully remove the cover plate (1) from the SWK (4). Make sure that the O-ring (3) remains in the SWK (4).

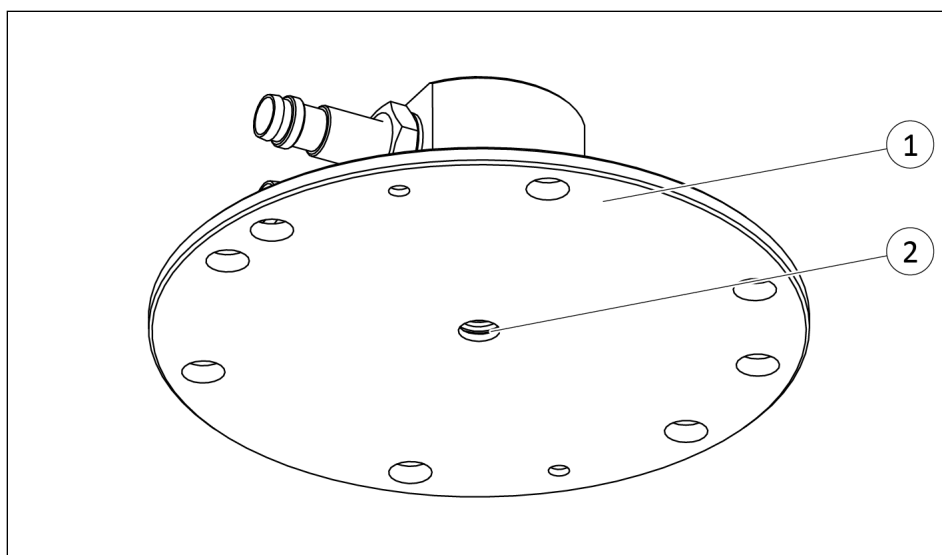

*Prepare sensor assembly*

- 6.** Check the O-ring (2) in the sensor assembly (1) and lubricate if necessary, ▶ 7.3 [ 88].

### Mount sensor assembly on SWK

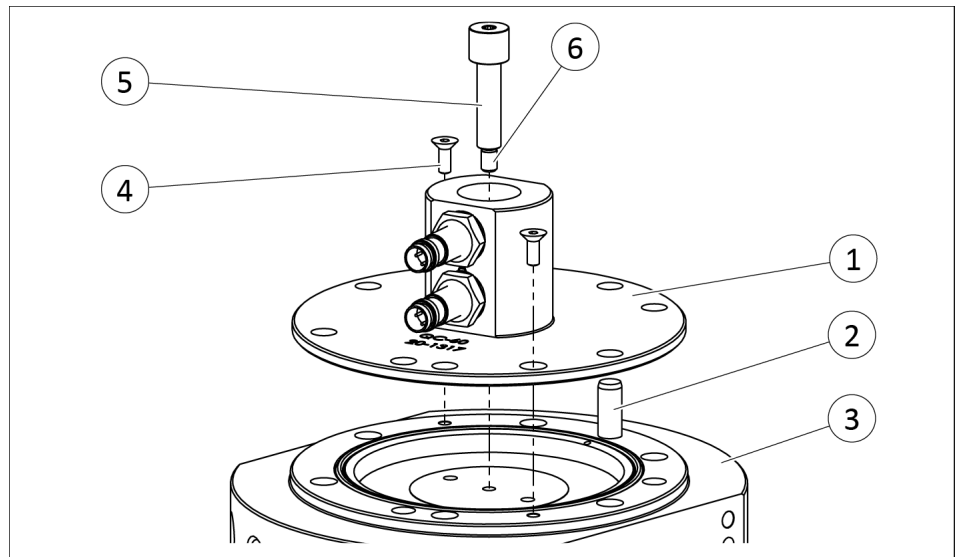

Mount sensor assembly on SWK

1. Protect the threads of the detection shaft (6) from lubricant with a strip of adhesive tape.
2. Lubricate the detection shaft (5), ▶ 7.3 [ 88].
3. Carefully push the detection shaft (5) into the sensor assembly (1) up to the stop.
4. Remove adhesive tape from the thread of the detection shaft (6).
5. Apply primer for the screw lock on the thread (6) of the detection shaft and briefly allow it to dry.
6. Apply screw lock to thread (6).
7. Align the sensor assembly (1) with the dowel pin (2) on the SWK (3).
8. Secure sensor assembly (1) to SWK (3) with screws (4).  
⇒ Max. tightening torque: 0.68 Nm

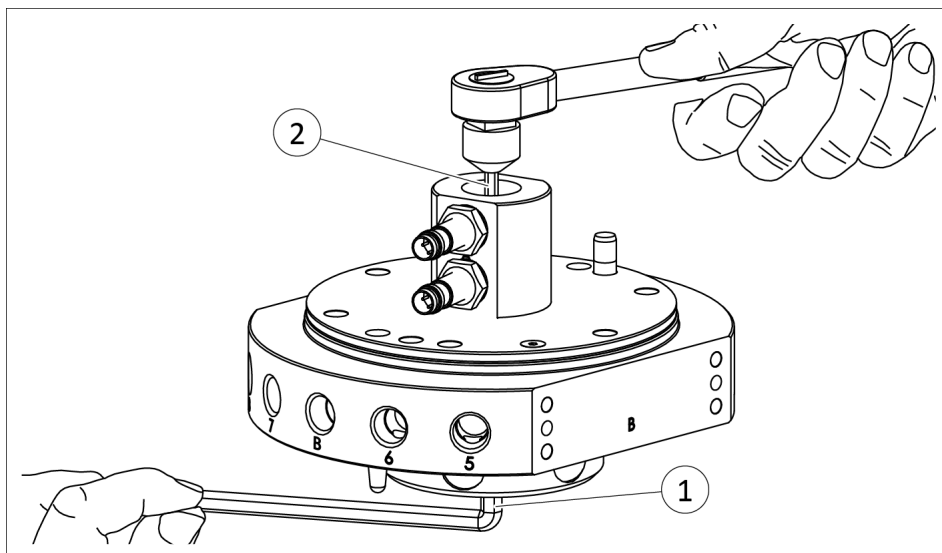

Tighten the detection shaft

9. Fix the cam of the SWK with a hexagon socket wrench (1) and tighten the detection shaft from above with a hexagon socket wrench (2).
  - ⇒ Observe the wrench size of the hexagon socket wrenches (1) and (2) and the max. tightening torque of the mounting screws for each size, see table "Mounting detection shaft", ▶ 5.4.5 [ 83].

### Check and adjust sensors

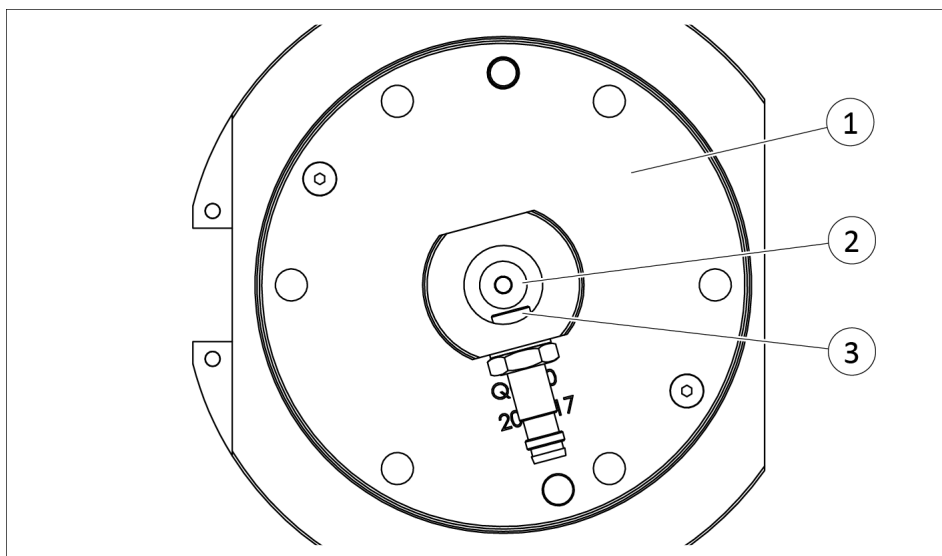

Check detection shafts and sensors

1. Look at the sensor assembly from above.
2. Make sure that the detection shaft and sensors are not touching each other, readjust the distance if necessary.

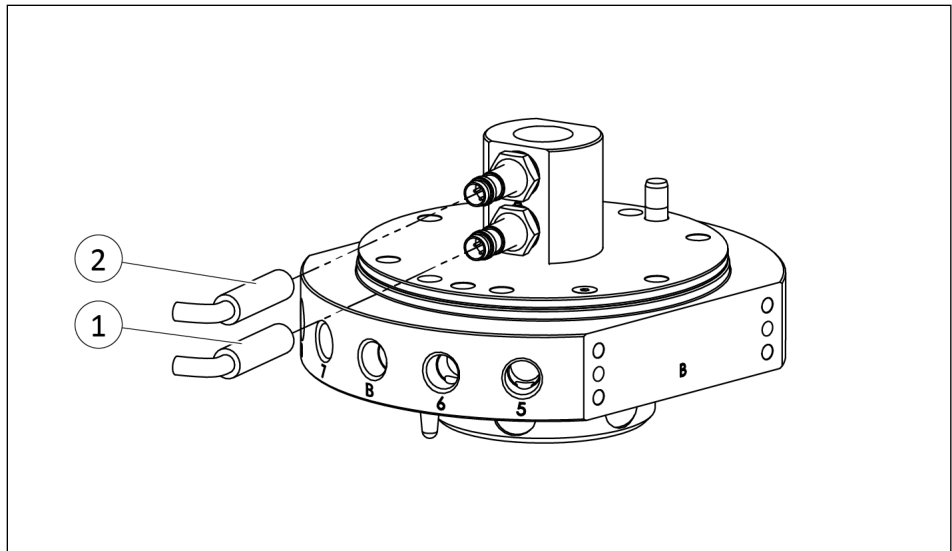

Connect sensor cable

3. Connect sensor cables (1) and (2) to sensors and to robot control system.
4. Connect all compressed air lines.
5. Switch on energy supply.
6. Lock and unlock the locking piston and check the signals of the sensors.

**Mount SWK with sensor assembly to the robot**

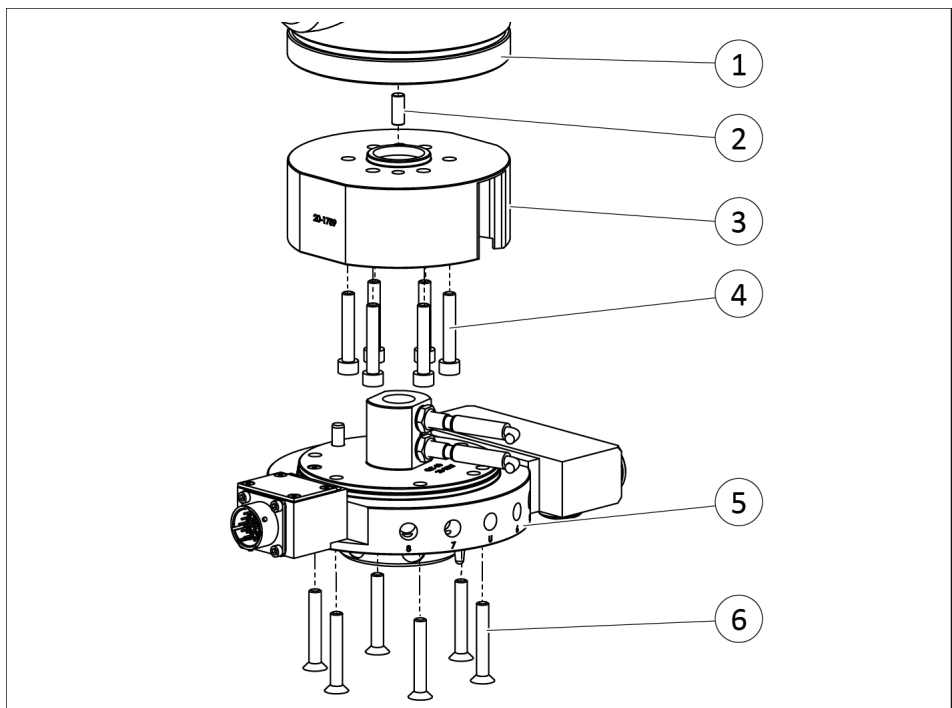

Mount SWK with adapter plate to the robot

1. Mount the adapter plate for the sensor assembly (3) to the robot (1) with the dowel pin (2) and screws (4).
  - ⇒ The dowel pin and screws depend on the robot and are not included in the scope of delivery.

2. Mount the SWK (5) to the adapter plate for sensor assembly (3) with screws (6).
  - ⇒ Observe the wrench size of the hexagon socket wrench and the max. tightening torque of the mounting screws for each size, see table "Mounting the SWK to the adapter plate for sensor assembly", ► 5.4.5 [83].
  - ⇒ SWK can be used with an external piston stroke control.

### 5.4.4 Mount sensor ready-to-lock

#### NOTE

For the sizes SWS 076, SWS 110 and SWS 160, presence monitoring can be mounted to the SWK. The associated sensor target on the SWA is integrated as standard.

For more information, please contact SCHUNK.

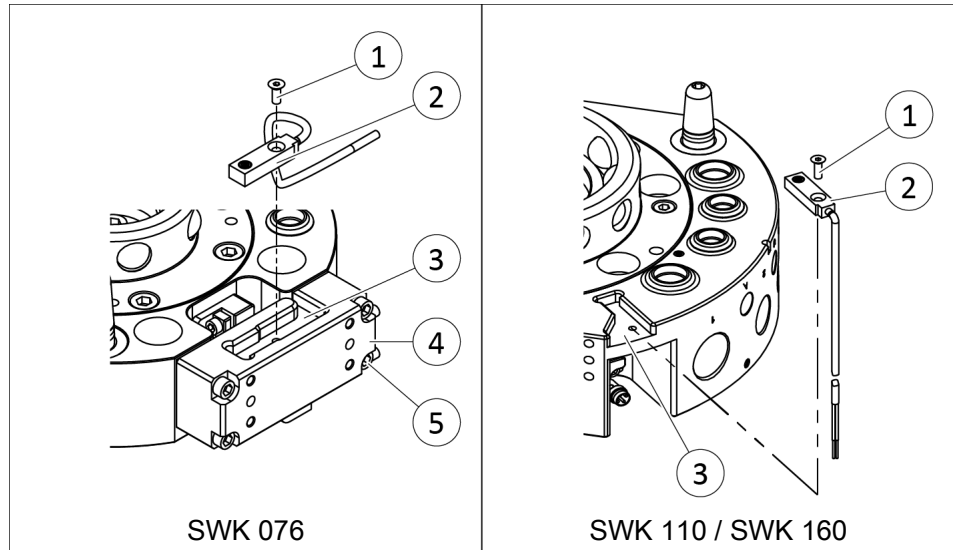

Mount presence monitoring

1. Place the SWA in the storage rack, secure and uncouple it.
2. Switch off the power supply and ensure that there is no residual energy in the system.
3. Remove the compressed air hose.
4. Disassemble the SWK from the robot and safely set the SWK aside, ▶ 7.4 [ 89].
5. **Only for SWS 076:** Mounting kit for sensor (4), included in scope of delivery, fasten to the SWK with screws (5).
6. **Only for SWS 076:** Guide the sensor cable downwards between the mounting kit (4) and SWK (3).
7. Apply screw lock to screw (1).
8. Fasten sensor (2) with screw (1) in recess (3).
  - ⇒ Max. tightening torque: 0.4 Nm
9. Repeat assembly for affected SWA.
10. Hold the ferromagnetic object against the sensor surface and test the presence monitoring LED.
  - ⇒ The sensor LED will illuminate.

### 5.4.5 Wrench sizes and tightening torques

SWS	Wrench size (SW) of hexagon socket wrench [mm]		Max. tightening torque [Nm]
	Cam	Detection shaft	
011	3	2.5	1.36
020	4	2.5	1.36
021	4	2.5	1.36
041	4	3	1.69
060	5	3	1.69
071	5	3	1.69

Tab.: Installing detection shaft

SWS	Wrench size (SW) of hexagon socket wrench [mm]	Fastening screw	Max. tightening torque [Nm]
011	2	M3	1.13
020	2.5	M4	1.13
021	2.5	M4	1.13
041	3	M5	5.08
060	4	M6	6.78
071	4	M6	6.78

Tab.: Mount SWK to adapter plate for sensor assembly

## 5.5 Mount the optional module

### NOTICE

#### Damage to pin block possible!

The pin block of the electric feed-through module at the SWK must always exactly match the pin block of the electric feed-through module on the SWA to avoid malfunctions and short circuits.

- After all work on the optional module, check the fit of the two parts.
- Carefully monitor the commissioning of new optional modules.

---

### NOTE

SWS 001 only with two optional modules. Operation with only one optional module can lead to an imbalance of the quick-change system.

1. Place the SWA in the storage rack, secure and uncouple it.
2. Switch off the power supply and ensure that there is no residual energy in the system.
3. Remove the compressed air hose.
4. Disassemble the SWK from the robot and safely set the SWK aside, ▶ 7.4 [📄 89].
5. Check the mounting patterns of SWK and SWA for a flush fit. Use adapter plate if necessary.
6. Mount optional modules on SWK and SWA according to the screw connection diagram.
7. Establish media connections to optional modules.

For further information, please refer to the catalog data sheets for optional modules SW0-E and SW0-F, ▶ 1.1.3 [📄 8].

## 6 Troubleshooting

### 6.1 Product does not lock or unlock

Possible cause	Corrective action
Contamination between SWK and SWA.	Disassemble and clean the product. ▶ 7.5 [ 90]
Locking balls or locking piston tilted.	Clean and lubricate product. ▶ 7.5 [ 90]
Locking ball missing.	Send damaged products to SCHUNK for repair.
Pressure drops below minimum.	Check compressed air lines. ▶ 5.3 [ 56] Check seals, disassemble product if necessary and replace seals. ▶ 7.6 [ 93]
Compressed air in the locking or unlocking connection cannot escape.	Vent connection. ▶ 5.3 [ 56]

#### Release the locking manually

#### NOTE

If the compressed air supply fails, the SWK 001 can be unlocked manually and the SWA can be disconnected from the SWK.

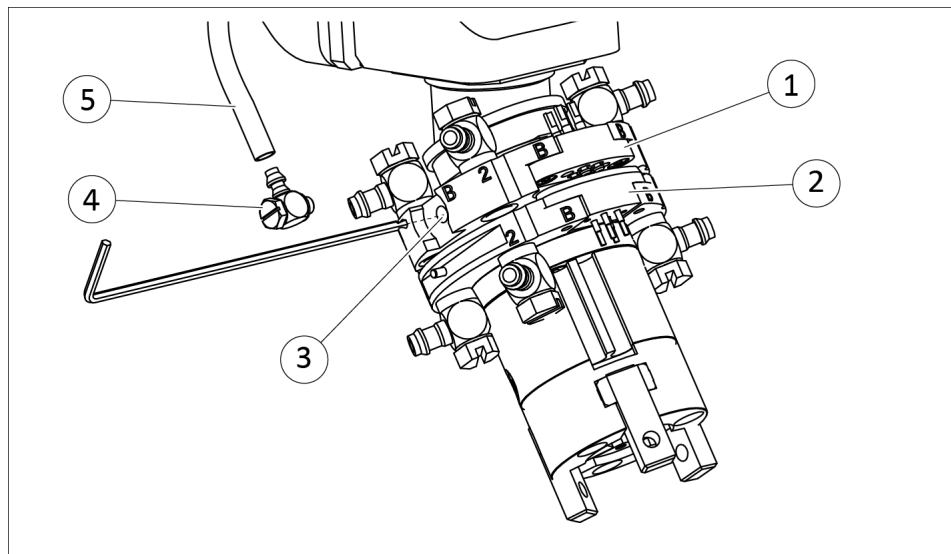

Release locking on SWS 001 manually

1. Move the product to the deposit position.
2. Remove the compressed air line (5) from the elbow fitting (4).
3. Remove elbow fitting (4) from SWK (1).
4. **CAUTION! Risk of injury from falling objects! Secure SWA (2) and end effector against falling**  
Insert hexagon socket wrench with ball head into locked connection (3) and manually unlock locking piston by pressing.
5. Release SWA (2) from the SWK (1).

## 6.2 Electrical signals are not transmitted

Possible cause	Corrective action
Pin block dirty or damaged.	Clean or replace the pin block. ▶ 7.9 [109]
Spring contact jammed in pin block or damaged.	Loosen or replace spring contact. ▶ 7.9 [109]
Cable damaged or connection loose	Check cables and connections for damage and replace, if necessary.

## 6.3 Locking or unlocking signal faulty

Possible cause	Corrective action
Sensor defective or incorrectly adjusted.	Adjust or replace sensor. ▶ 7.8 [101]
Sensor cable damaged or connection loose.	Check cables and connections for damage and replace, if necessary.

## 6.4 Tool presence monitoring faulty

Possible cause	Corrective action
Sensor defective or incorrectly adjusted.	Adjust or replace sensor. ▶ 7.8 [101]
Sensor cable damaged or connection loose.	Check cables and connections for damage and replace, if necessary.
End effector not placed correctly.	Check end effector in the storage rack. Re-teach the robot if necessary.

## 7 Maintenance

### 7.1 Notes

#### Original spare parts

Use only original spare parts of SCHUNK when replacing spare and wear parts.

### 7.2 Maintenance intervals

#### NOTICE

#### Material damage due to hardening lubricants!

Lubricants harden more quickly at temperatures above 60°C, leading to possible product damage.

- Reduce the lubricant intervals accordingly.

Ambient conditions and operating conditions	Maintenance interval	Maintenance work
in dirty environments or with a tool change > 1 time per minute	weekly	Clean all parts thoroughly, check for damage and wear and grease with a lint-free cloth or brush, ▶ 7.5 [ 90].
tool change < 1 time per week	monthly	<p>Check product for tightness, replace seals if necessary, ▶ 7.6 [ 93].</p> <p>Check alignment pins for damage and wear, replace if necessary, ▶ 7.7 [ 98].</p> <p>Check sensors for damage and wear, replace if necessary, ▶ 7.8 [ 101].</p> <p>Check optional modules for damage and wear, clean if necessary and replace seals, ▶ 7.9 [ 109].</p>
all	as required	Send damaged products to SCHUNK for repair.

### 7.3 Lubricants/greasing areas

During maintenance, treat all greased areas with lubricant. Thinly apply lubricant with a lint-free cloth.

SCHUNK recommends the listed lubricant.

Lubricant point	Lubricant
Male coupling	SCHUNK grease 1
Centering / locking sleeve	
Locking ball	
Cam	
Alignment pin	
Seals and sealing surfaces	SCHUNK grease 1
Detection shaft	

Details regarding SCHUNK lubricant designations are available at [schunk.com/lubricants](https://www.schunk.com/lubricants).

The product contains food-compliant lubricants as standard.

**The requirements of standard EN 1672-2:2020 are not fully met.**

#### NOTE

- Change contaminated food-compliant lubricant.
- Observe information in the safety data sheet from the lubricant manufacturer.

## 7.4 Removing the product from the robot arm



### ⚠ WARNING

#### Risk of injury due to unexpected movements and falling tools!

If the energy supply is switched on or if residual energy is still present in the system, this can cause components to move unexpectedly or fall, which may result in serious injuries.

- Before starting any work on the product: Switch off the energy supply and secure against re-connection.
- Ensure that no residual energy remains in the system.
- Only carry out maintenance work when the tool is placed in the storage rack or secured against falling.

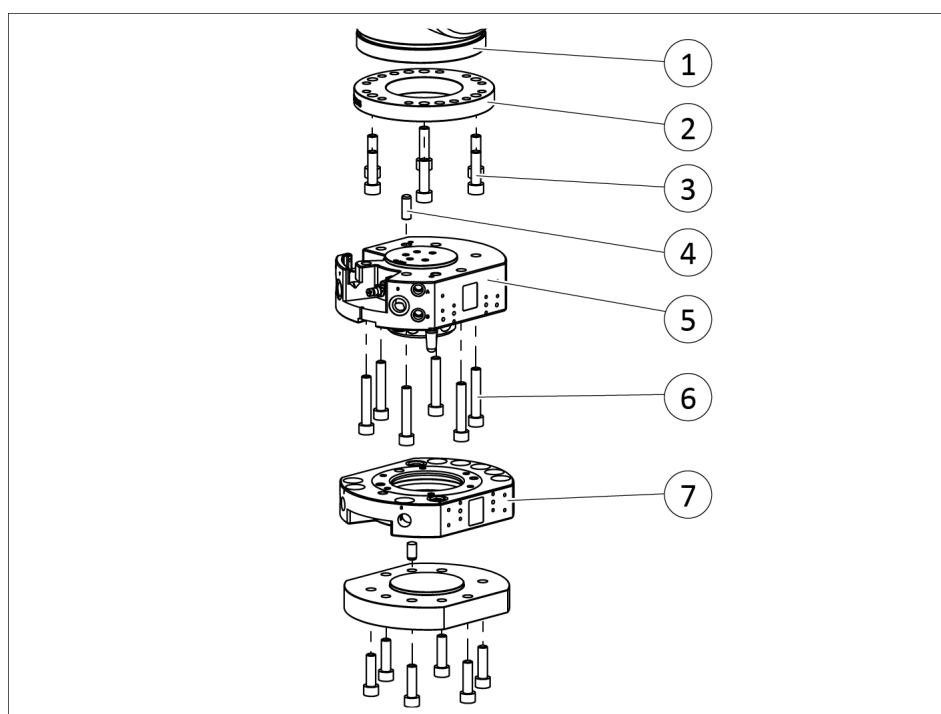

*Disassemble the product from the robot*

1. Place the SWA (7) in the storage rack, secure and uncouple it.
2. Switch off and deactivate all activated supply circuits (e.g. electrical, air, water, etc.).
3. Loosen screws (6) and remove SWK (5) from the robot (1). Make sure that the dowel pin (4) does not fall off.
4. Put down the SWK (5).
5. **When using an adapter plate:** Loosen screws (3) and remove adapter plate (2) from the robot (1).

## 7.5 Clean and lubricate product

### SWS 001

1. Place the SWA in the storage rack, secure and uncouple it.
2. Remove the compressed air hose.
3. Switch off the power supply and ensure that there is no residual energy in the system.
4. Disassemble the SWK from the robot and safely set the SWK aside, ▶ 7.4 [ 89].

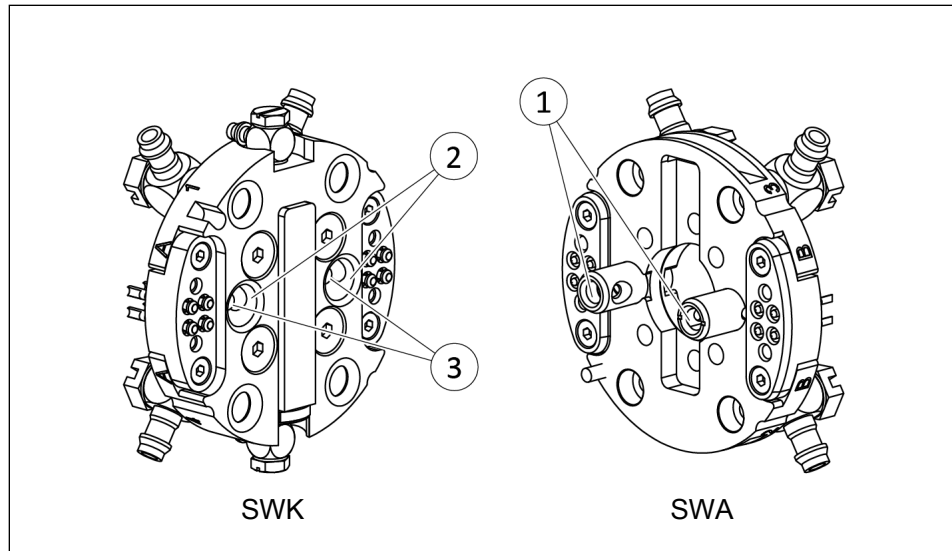

Clean and lubricate SWS 001

5. Remove lubricant residues and dirt from the centering / locking sleeve (1) on the SWA and the locking mechanism (2) and alignment pin (3) on the SWK.
6. Lubricate the centering / locking sleeve (1) on the SWA, ▶ 7.3 [ 88].

---

### NOTE

Locking mechanism (2) and alignment pin (3) on the SWK are sufficiently lubricated at the factory and do not need to be relubricated.

---

### SWS 005 SWS 011

1. Place the SWA in the storage rack, secure and uncouple it.
2. Switch off the power supply and ensure that there is no residual energy in the system.
3. Remove the compressed air hose.
4. Disassemble the SWK from the robot and safely set the SWK aside, ▶ 7.4 [ 89].

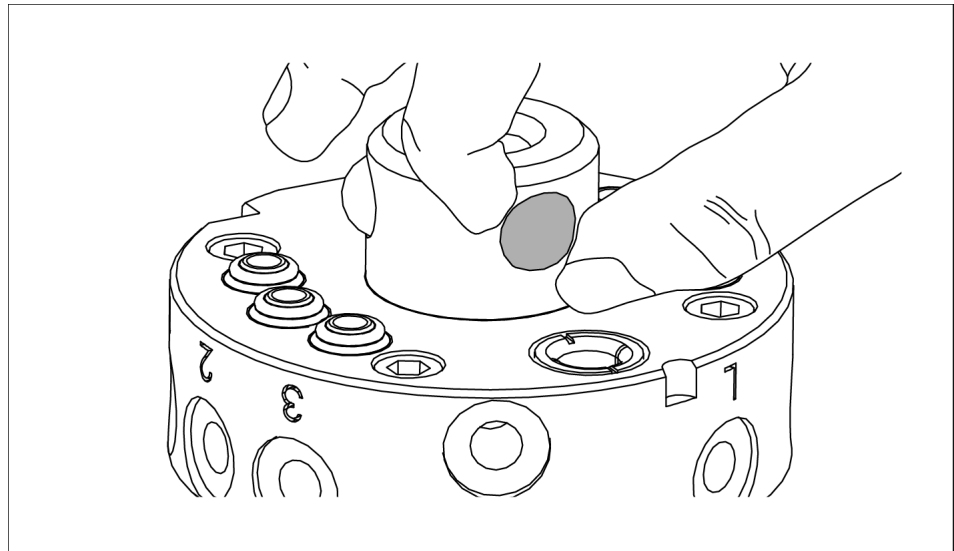

Check that the locking balls on the SWK can move

5. Check locking balls. Each ball must move freely in the ball bearing.
6. Loosen stuck balls and clean with a clean cloth.

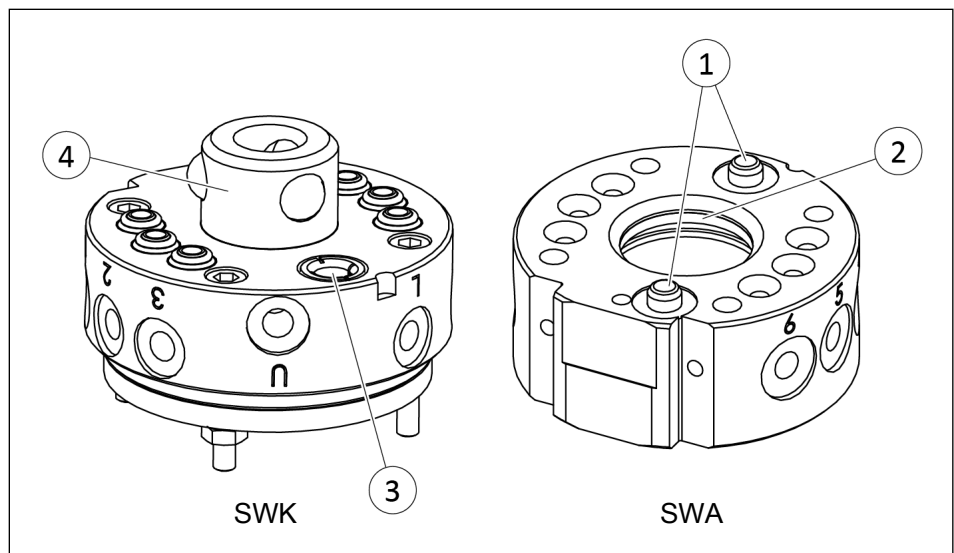

Clean SWS with a lint-free cloth

7. Remove lubricant residues and dirt from the alignment pin (1), bearing race (2), alignment pin bushings (3) and locking mechanism (4).
8. Generously lubricate the locking mechanism (4) and alignment pin (1), ► 7.3 [ 88].

### NOTE

The alignment pin bushings and the bearing race are sufficiently lubricated at the factory and do not need to be relubricated.

**SWS 020–SWS 160**

1. Place the SWA in the storage rack, secure and uncouple it.
2. Switch off the power supply and ensure that there is no residual energy in the system.
3. Remove the compressed air hose.
4. Disassemble the SWK from the robot and safely set the SWK aside, ▶ 7.4 [ 89].

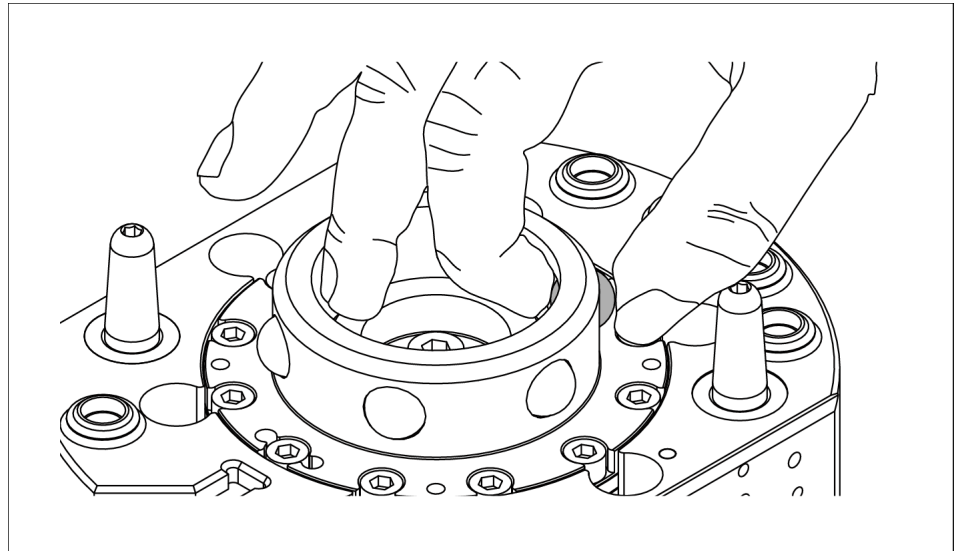

*Check that the locking balls on the SWK can move*

5. Check locking balls. Each ball must move freely in the ball bearing.
6. Loosen stuck balls and clean with a clean cloth.

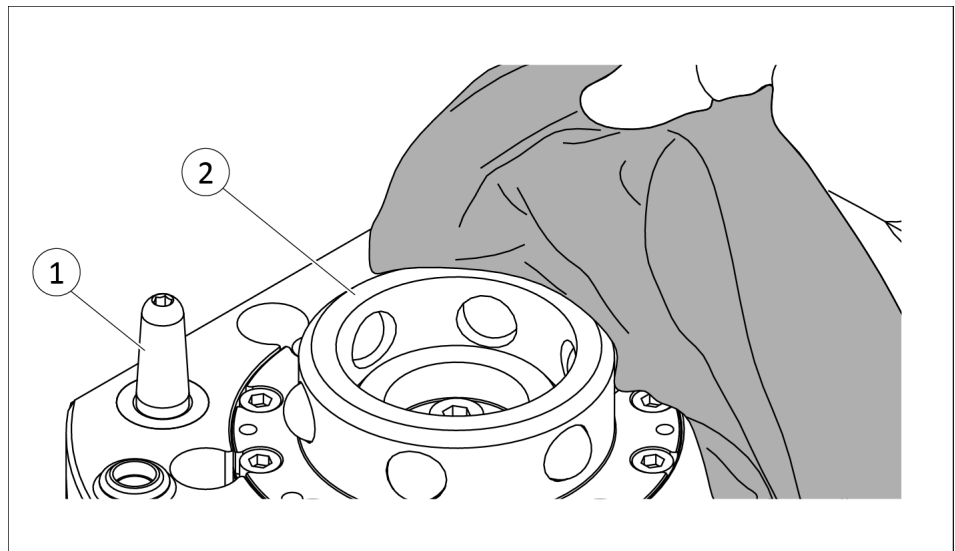

*Clean SWS with a lint-free cloth*

7. Remove lubricant residues and dirt from the alignment pin (1) and locking mechanism (2).

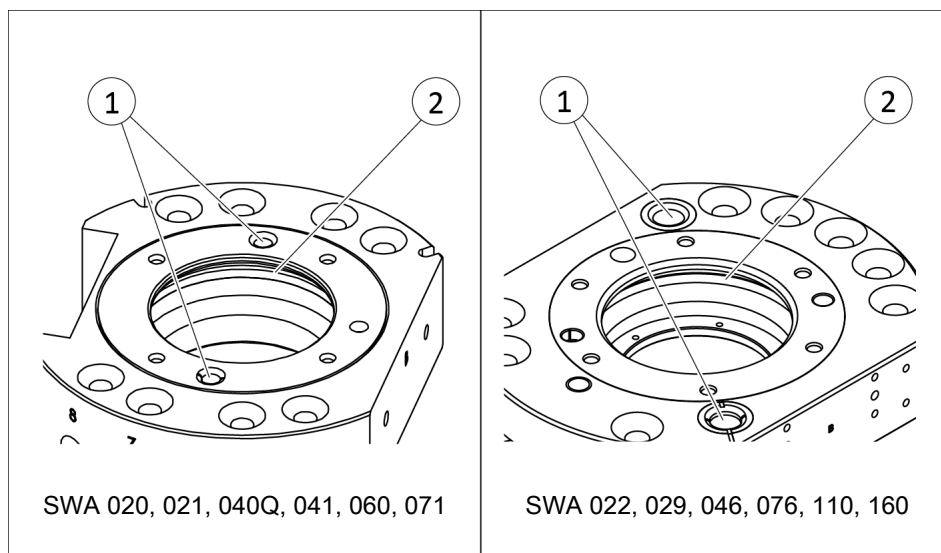

Clean the locking mechanism on the SWA

8. Clean the alignment pin bushing (1) and bearing race (2) and remove lubricant residues and dirt.

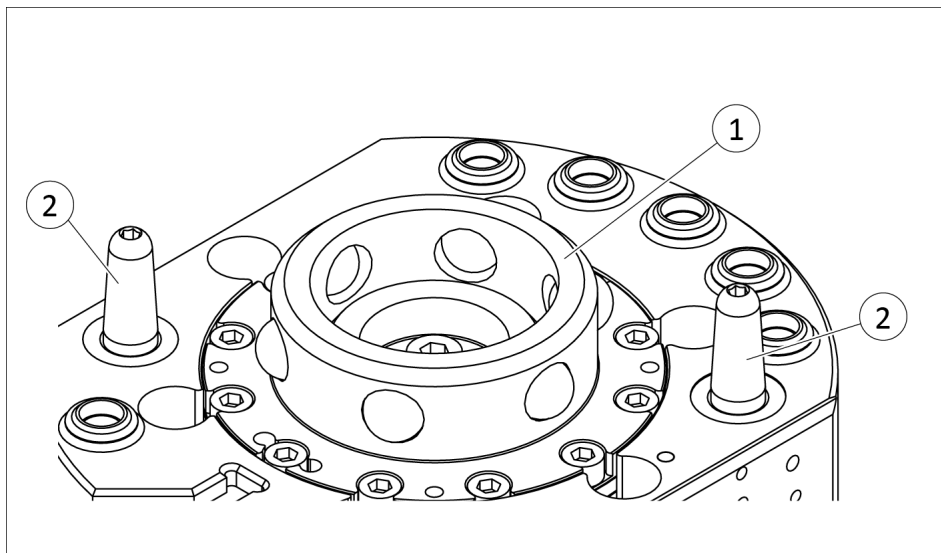

Lubricate locking mechanism and alignment pin on SWK

9. Generously lubricate the locking mechanism (1) and alignment pin (2), ▶ 7.3 [ 88].

#### NOTE

The alignment pin bushings and the bearing race are sufficiently lubricated at the factory and do not need to be relubricated.

## 7.6 Replace seals

### 7.6.1 Overview of the seals

#### NOTE

Information on the available seal kits in chapter ▶ 1.4 [ 8].

The seals on the pneumatic feed-throughs in the SWK may look as follows:

- O-ring (A)
- Rubber bushings (B)
- Rubber bushings with sleeve (C)

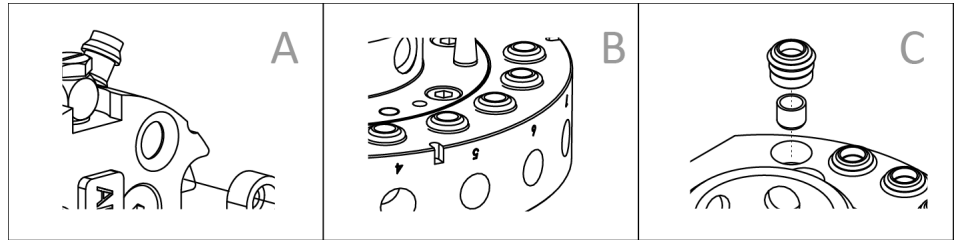

Seals on the pneumatic feed-throughs

SWS	A	B	C
001	X		
005		X	
007		X	
011		X	
011HM		X	
020		X	
020HM		X	
021		X	
021HM		X	
022			X
029		X	
040Q		X	
041		X	X
046		X	
071		X	
076			X
110			X
160			X

## 7.6.2 Change O-ring

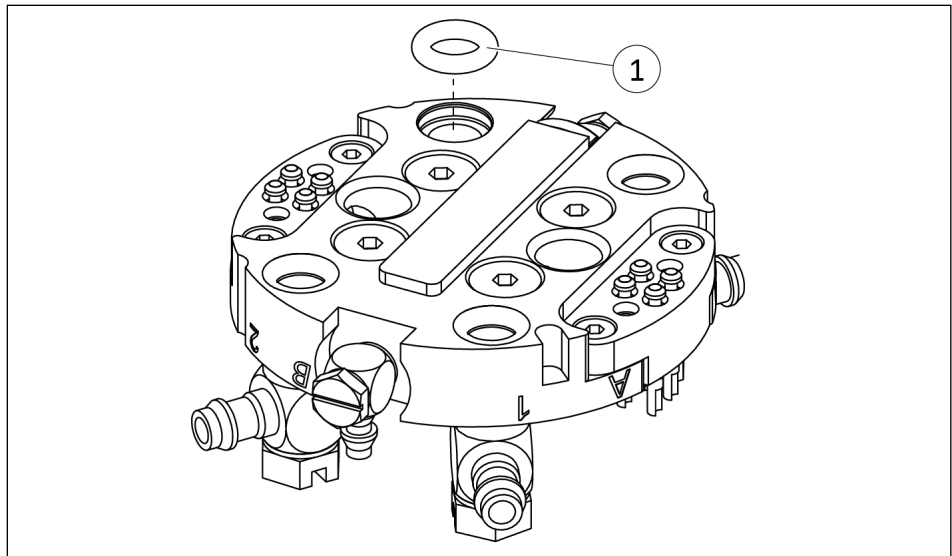

### *Change O-ring*

- 1.** Place the SWA in the storage rack, secure and uncouple it.
- 2.** Switch off the power supply and ensure that there is no residual energy in the system.
- 3.** Remove the compressed air hose.
- 4.** Disassemble the SWK from the robot and safely set the SWK aside, ▶ 7.4 [ 89].
- 5.** Remove damaged O-ring (1).
- 6.** Lightly lubricate the new O-ring (1), ▶ 7.3 [ 88].
- 7.** Carefully insert the O-ring (1) into the bore up to the stop.

### 7.6.3 Change rubber bushing

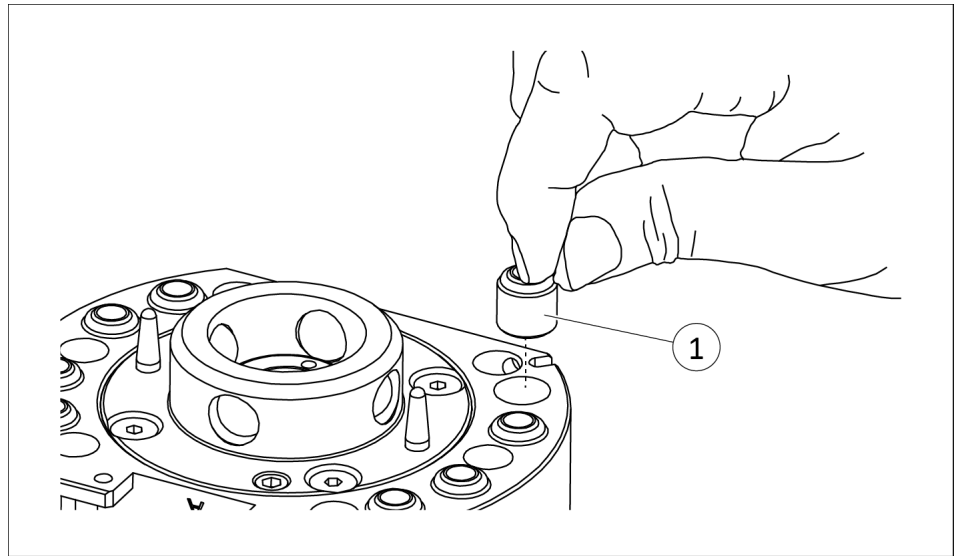

*Change rubber bushing*

1. Place the SWA in the storage rack, secure and uncouple it.
2. Switch off the power supply and ensure that there is no residual energy in the system.
3. Remove the compressed air hose.
4. Disassemble the SWK from the robot and safely set the SWK aside, ▶ 7.4 [ 89].
5. Remove damaged rubber bushing (1).
6. Lightly lubricate the new rubber bushing (1), ▶ 7.3 [ 88].
7. Carefully insert the rubber bushing (1) into the bore with the flat end up to the stop. The conical end points upwards.

### 7.6.4 Replace rubber bushing with sleeve

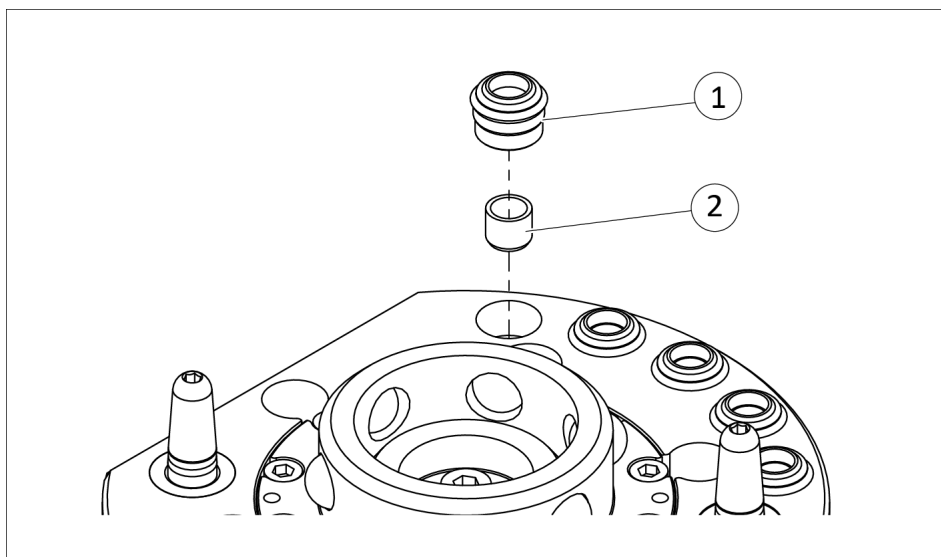

*Replace rubber bushing with sleeve*

1. Place the SWA in the storage rack, secure and uncouple it.
2. Switch off the power supply and ensure that there is no residual energy in the system.
3. Remove the compressed air hose.
4. Disassemble the SWK from the robot and safely set the SWK aside, ▶ 7.4 [ 89].
5. Remove damaged rubber bushing (1) and sleeve (2).
6. Lightly lubricate the new rubber bushing (1), ▶ 7.3 [ 88].
7. Carefully insert the rubber bushing (1) into the bore with the flat end up to the stop. The conical end points upwards.
8. Press sleeve (2) into the rubber bushing (1) up to the stop.

## 7.7 Change alignment pins

### NOTE

External alignment pins can be ordered as spare parts from SCHUNK.

### 7.7.1 External alignment pins

#### NOTE

The sizes SWS 007, SWS 022, SWS 029, SWS 046, SWS 076, SWS 110 and SWS 160 are mounted with external alignment pins.

#### 7.7.1.1 Disassemble external alignment pins

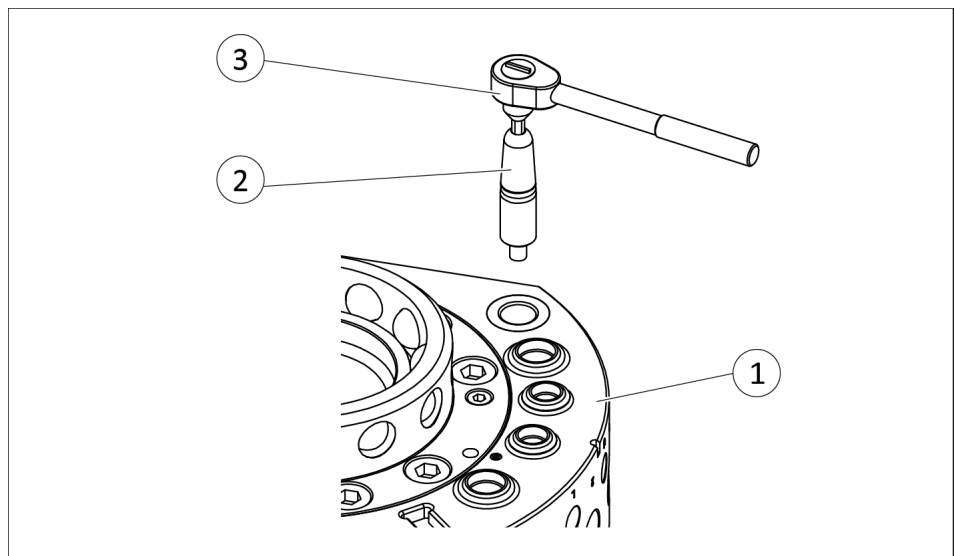

*Remove alignment pins*

1. Place the SWA in the storage rack, secure and uncouple it.
2. Switch off the power supply and ensure that there is no residual energy in the system.
3. Remove the compressed air hose.
4. Disassemble the SWK from the robot and safely set the SWK aside, ▶ 7.4 [ 89].
5. Remove all lubricant residue and dirt from the alignment pins (2).
6. Remove alignment pins (2) with ratchet (3) from SWK (1).  
⇒ Observe wrench size:

SWS	Wrench size of ratchet used [mm]
007	2.5
022	2.5
029	2.5
046	2.5

SWS	Wrench size of ratchet used [mm]
076	4
110	4
160	4

**NOTE**

If the alignment pin (3) cannot be loosened, remove the alignment pin (3) from below, ▶ 7.7.1.2 [ 99].

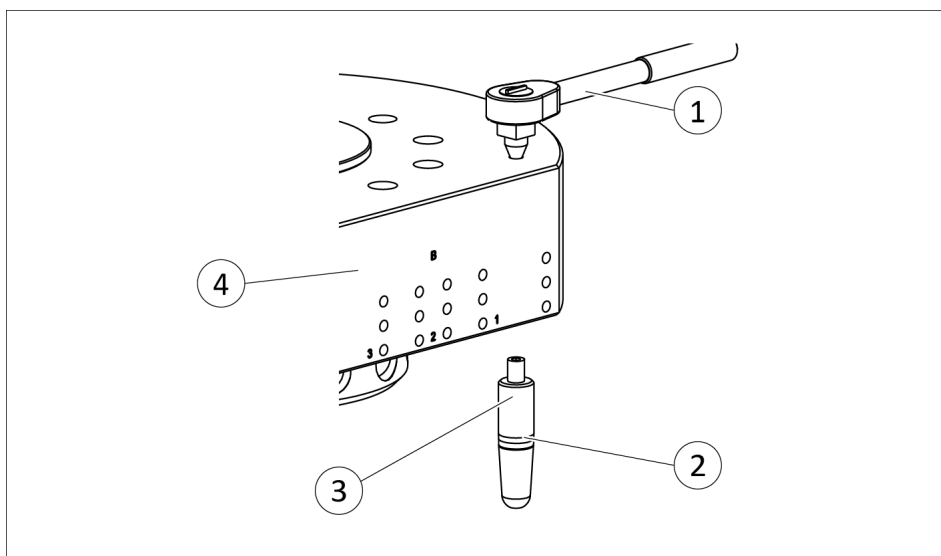
**7.7.1.2 Disassemble external alignment pins from below**

*Alternative option for disassembly of the alignment pin*

1. Turn SWK (4) over.
2. Loosen set screw (3) with ratchet (1) by turning counterclockwise.
3. Remove the alignment pins (2) downwards.

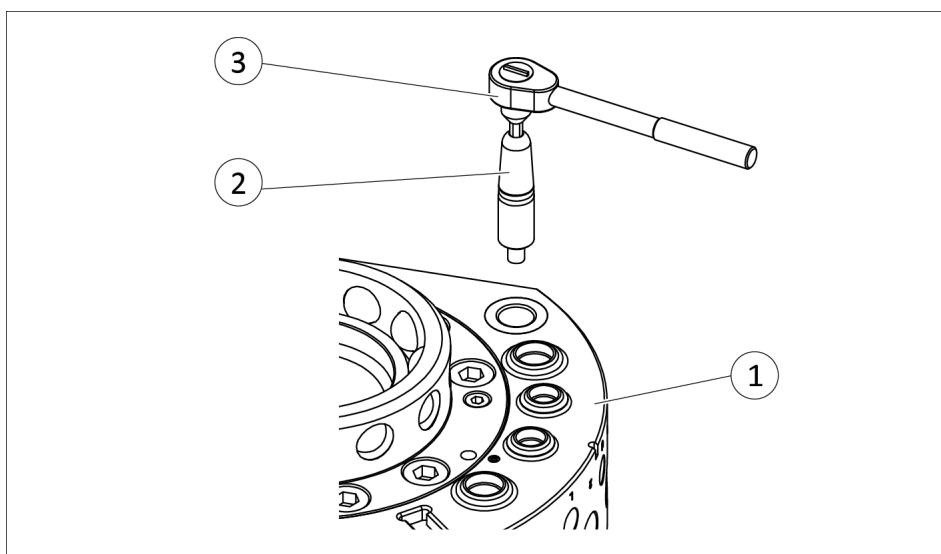
**7.7.1.3 Mount a new external alignment pin**

*Mount a new alignment pin*

1. Apply screw lock to new alignment pin (3).
2. Insert a new alignment pin (3) in the bore for alignment pins (5) and tighten with ratchet (1).
  - ⇒ Permissible tightening torque: 6.8 Nm
3. Lubricate the new alignment pin (3), ▶ 7.3 [📄 88].

### 7.7.2 Internal alignment pins

---

#### **NOTE**

The sizes SWS 005, SWS 011, SWS 020, SWS 021, SWS 040Q, SWS 041, SWS 060 and SWS 071 are mounted with internal alignment pins. They are installed in the male coupling.

---

- Please contact SCHUNK for the replacement of internal alignment pins.

## 7.8 Change sensors

### 7.8.1 Change integrated piston stroke control



#### ⚠ CAUTION

##### Risk of injury from objects flying out!

Do not apply compressed air to the compressed air connections during assembly of the piston stroke control, as parts may come loose or the adapter plate or the O-ring may be damaged.

- Only apply compressed air to the pneumatic connection when the SWK is mounted on the robot.

#### NOTE

The integrated piston stroke control can be retrofitted if required. The installation for retrofitting is carried out in the same way as for replacement. Contact SCHUNK for ordering retrofit parts.

SWS

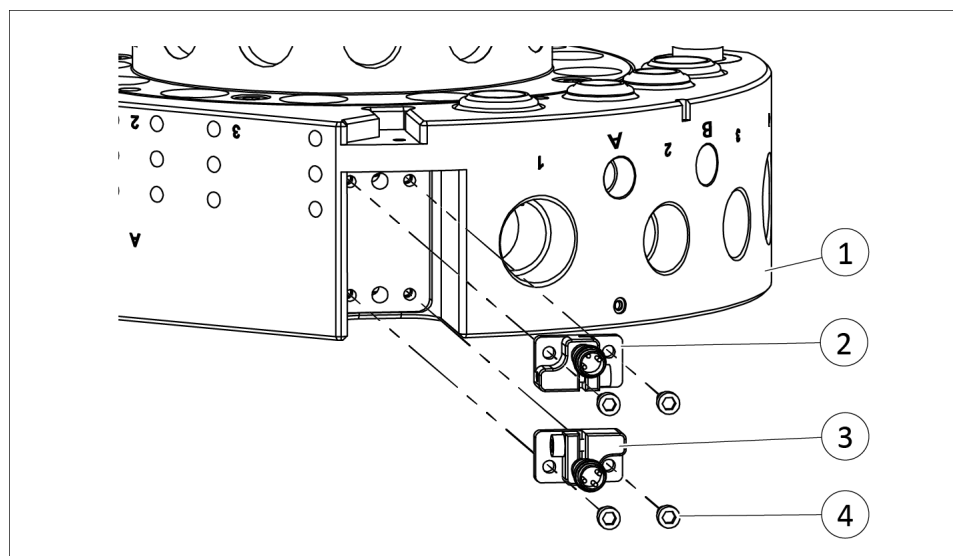

*Change integrated piston stroke control*

1. Place the SWA in the storage rack, secure and uncouple it.
2. Switch off the power supply and ensure that there is no residual energy in the system.
3. Remove the compressed air hose.
4. Disassemble the SWK from the robot and safely set the SWK aside, ▶ 7.4 [ 89].
5. Check sensor cable for damage, replace if necessary.
6. **For retrofitting:** Remove the protective cover from the bores on the SWK.  
**For replacement:** Loosen the mounting screws and remove the sensor assembly with damaged sensor from SWK.

7. Secure the new sensor assembly lock (2) or monitoring of unlocking (3) to the SWK (1) with screws (4).  
⇒ Max. tightening torque: 1.4 Nm
8. Connect cable to sensor assembly (2) and (3).
9. Lock and unlock the locking piston manually.
10. Connect all compressed air lines.
11. Switch on energy supply.
12. Lock and unlock the locking piston and check the signals of the sensors.

**SWS for hollow wrist robots**

**SWS 011HM**

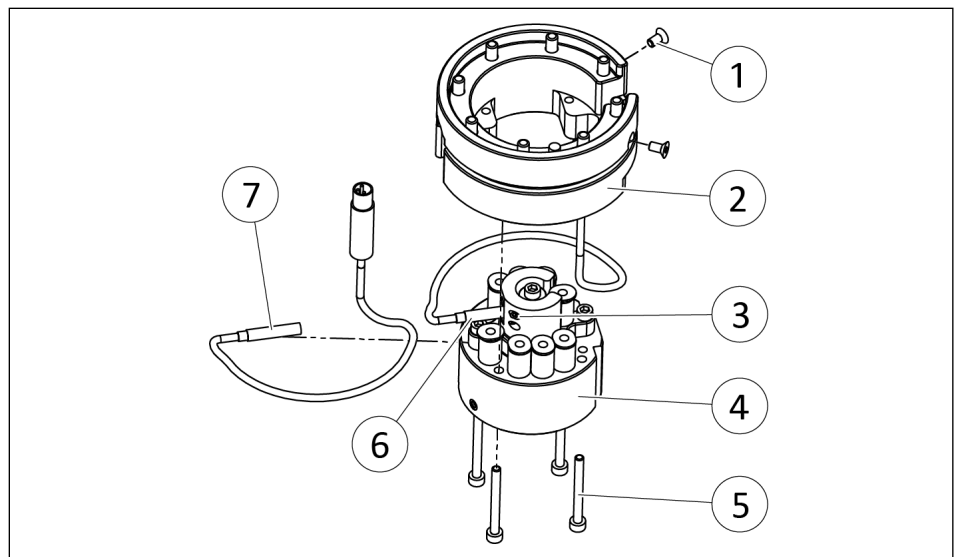

*SWS 011HM: Change integrated piston stroke control*

**Remove defective sensor assembly**

1. Place the SWA in the storage rack, secure and uncouple it.
2. Disassemble the SWK from the robot and safely set the SWK aside, ▶ 7.4 [ 89].
3. Lock and unlock the locking piston and check the signals of the sensors.
4. Check sensor cable for damage, replace if necessary.
5. Switch off the power supply and ensure that there is no residual energy in the system.
6. Loosen the screws (1).
7. Loosen screws (5) and remove adapter plate (2) from SWK (4).  
**NOTICE! Damage to the sensor cable possible! When removing the adapter plate, make sure that the sensor cable has sufficient play.**
8. Remove sensor cable and compressed air lines.
9. Loosen screw (3) and remove damaged sensor (6) or (7).

### Mount new sensor assembly

1. Carefully screw the new sensor (6) or (7) into SWK (4) until the sensor (6) or (7) touches the detection shaft.
2. Unscrew sensor (6) or (7) by half a turn.
3. Hold sensor (6) or (7) in this position and connect sensor cable.
  - ⇒ The sensor LED will illuminate.
4. Apply screw lock to screw (3) and fasten sensor (6) or (7) with screw (3).

**WARNING! Risk of damage to the sensor! Carefully tighten screw (3) until screw (3) engages in the sensor thread, then tighten another 1/4 turn.**

### Check new sensor assembly

1. Connect all compressed air lines.
2. Secure the adapter plate (2) to SWK (4) with screws (5).
  - ⇒ Max. tightening torque: 1.13 Nm
3. Guide the sensor cable along the cable ducts in the adapter plate (2) and secure it with screws (1).
  - ⇒ Max. tightening torque: 0.9 Nm
4. Lock and unlock the locking piston and check the signals of the sensors.

### SWS 020HM / 021HM

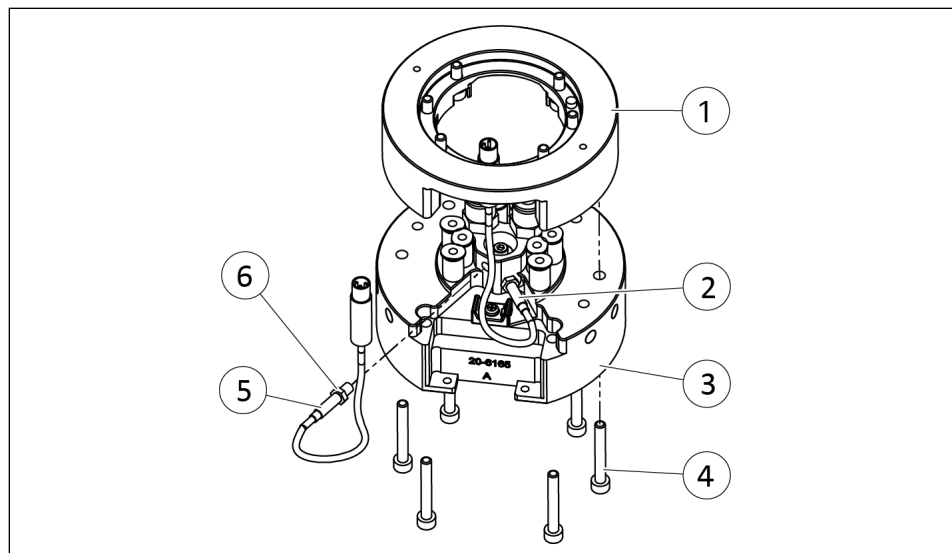

SWS 020HM / 021HM: Change integrated piston stroke control

### Remove defective sensor assembly

1. Place the SWA in the storage rack, secure and uncouple it.
2. Disassemble the SWK from the robot and safely set the SWK aside, ▶ 7.4 [ 89].

3. Lock and unlock the locking piston and check the signals of the sensors.
4. Check sensor cable for damage, replace if necessary.
5. Switch off the power supply and ensure that there is no residual energy in the system.
6. Loosen screws (4) and remove adapter plate (1) from SWK (3).  
**NOTICE! Damage to the sensor cable possible! When removing the adapter plate, make sure that the sensor cable has sufficient play.**
7. Remove sensor cable and compressed air lines.
8. Loosen hexagon nut (6) and remove damaged sensor (2) or (5).

#### **Mount new sensor assembly**

1. Screw hexagon nut (6) onto new sensor (2) or (5).
2. Screw new sensor (2) or (5) into SWK (3) until sensor (2) or (5) touches the detection shaft.
3. Unscrew sensor (2) or (5) by half a turn.
4. Hold sensor (2) or (5) in this position and connect sensor cable.  
⇒ The sensor LED will illuminate.
5. Apply screw lock to the thread of the sensor (2) or (5).
6. Tighten the hexagon nut (6).  
⇒ Max. tightening torque: 0.9 Nm

#### **Check new sensor assembly**

1. Connect all compressed air lines.
2. Attach the adapter plate (1) to the SWK (3) with screws (4).  
⇒ Max. tightening torque: 1.7 Nm
3. Secure the sensor cable to the adapter plate (1).
4. Lock and unlock the locking piston and check the signals of the sensors.

## 7.8.2 Change external piston stroke control

SWS 011 / 020 / 021

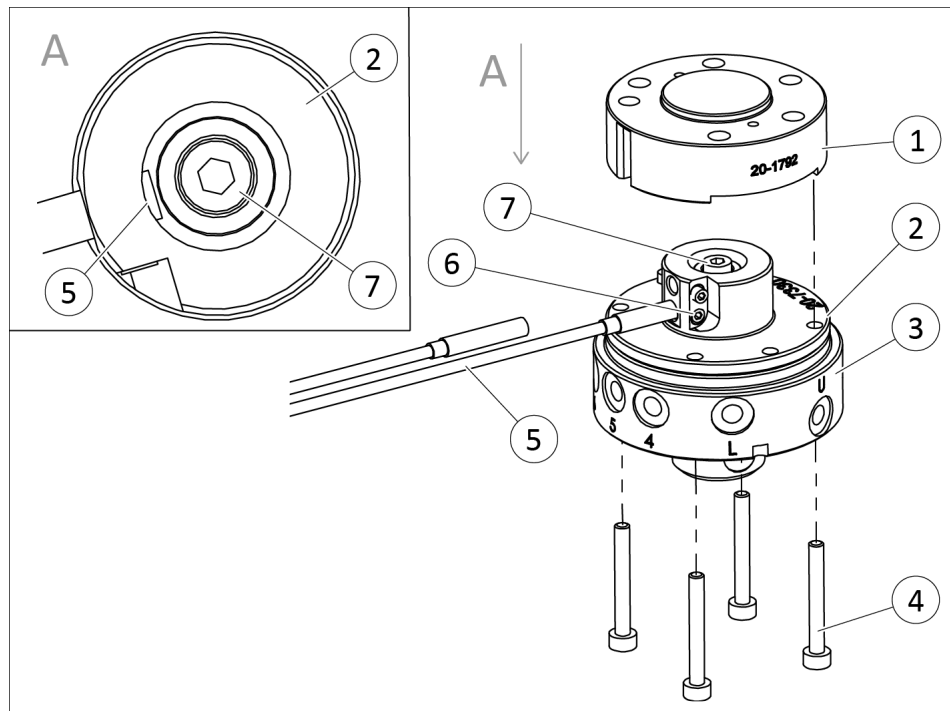

Change external piston stroke control, A = View from above, shown as an example on SWK 011

### Remove defective sensor assembly

1. Place the SWA in the storage rack, secure and uncouple it.
2. Loosen screws (4) and remove SWK (3) from the adapter plate for sensor assembly (1).
3. Check sensor cable for damage, replace if necessary.
4. Lock and unlock the locking piston and check the signals of the sensors.
5. Switch off the power supply and ensure that there is no residual energy in the system.
6. Remove the compressed air hose.
7. Loosen screw (6) and unscrew the damaged sensor (5) from the sensor assembly (2).

### Mount new sensor assembly

1. Screw new sensor (5) into SWK (3) until sensor (5) touches the detection shaft.
2. Turn the sensor (5) half a turn out of its fitting.
3. Look at the sensor assembly from above.
4. Ensure that the detection shaft (7) and sensors (5) do not touch each other, readjust the distance if necessary.

5. Apply screw lock to screw (6) and fasten sensor (5) with screw (6).

**NOTICE! Risk of damage to the sensor! Carefully screw in screw (6) until screw (6) touches the sensor, then tighten an additional approx. 1/4 turn.**

**Check new sensor assembly**

1. Switch on power supply.
  - ⇒ The sensor LED will illuminate.
  - ⇒ Sensor signal is ON.
2. Mount the SWK (3) to the adapter plate for sensor assembly (1) with screws (4).
- ⇒ Observe the tightening torque for the mounting screws.
3. Connect all compressed air lines.
4. Lock and unlock the locking piston and check the signals of the sensors.

**SWS 041 / 060 / 071**

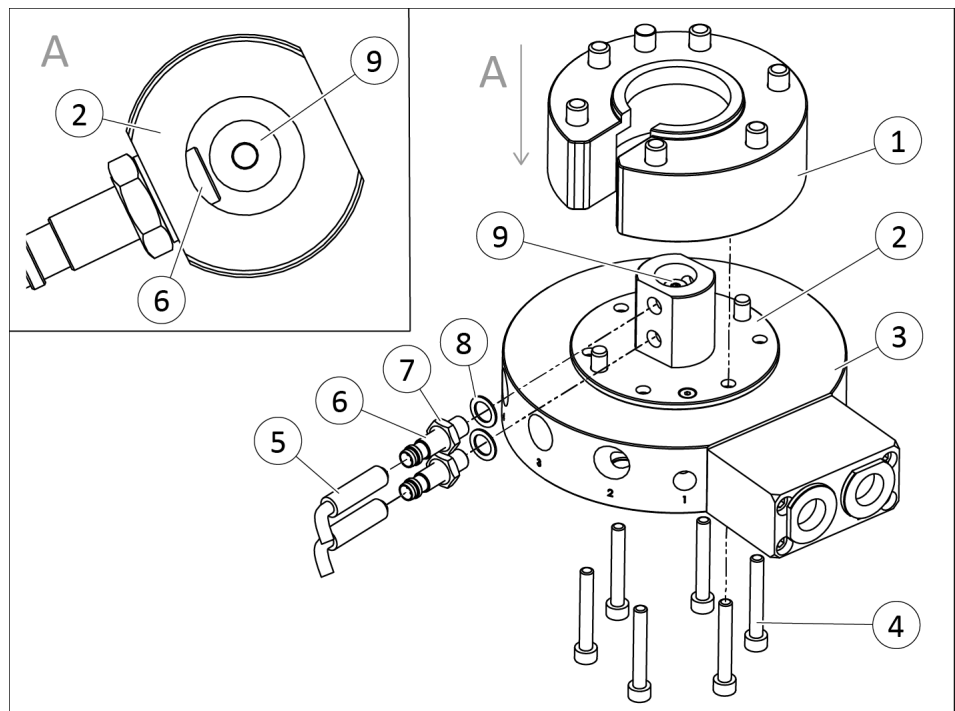

*Change external piston stroke control, A = View from above, shown as an example on SWK 041*

**Remove defective sensor assembly**

1. Place the SWA in the storage rack, secure and uncouple it.
2. Loosen screws (4) and remove SWK (3) from the adapter plate for sensor assembly (1).
3. Check sensor cable for damage, replace if necessary.
4. Lock and unlock the locking piston and check the signals of the sensors.

5. Switch off the power supply and ensure that there is no residual energy in the system.
6. Remove the compressed air hose.
7. Remove sensor cable (5).
8. Loosen the hexagon nut (7) and unscrew the sensor (6) from the sensor assembly (2).
9. Remove washer (8) from sensor (6).

#### **Mount new sensor assembly**

1. Screw hexagon nut (7) onto new sensor (6).
2. Screw the new sensor (6) with washer (8) into the sensor assembly (2) until sensor (6) touches the detection shaft (9).
3. Unscrew sensor (6) again by half a turn.
4. Look at the sensor assembly from above.
5. Check that the detection shaft (9) and sensor (6) do not touch each other, readjust the distance if necessary.
6. Apply screw lock to the thread of the sensor (6).
7. Tighten the hexagon nut (7).
  - ⇒ Max. tightening torque: 2.3 Nm

#### **Check new sensor assembly**

1. Connect the sensor cable (5).
2. Switch on power supply.
  - ⇒ The sensor LED will illuminate.
  - ⇒ Sensor signal is ON.
3. Connect all compressed air lines.
4. Mount the SWK (3) to the adapter plate for sensor assembly (1) with screws (4).
  - ⇒ Observe the wrench size of the hexagon socket wrench and the max. tightening torque of the mounting screws for each size, see table "Mounting the SWK to the adapter plate for sensor assembly", ► 5.4.5 [ 83].
5. Lock and unlock the locking piston and check the signals of the sensors.

### 7.8.3 Change sensor ready-to-lock

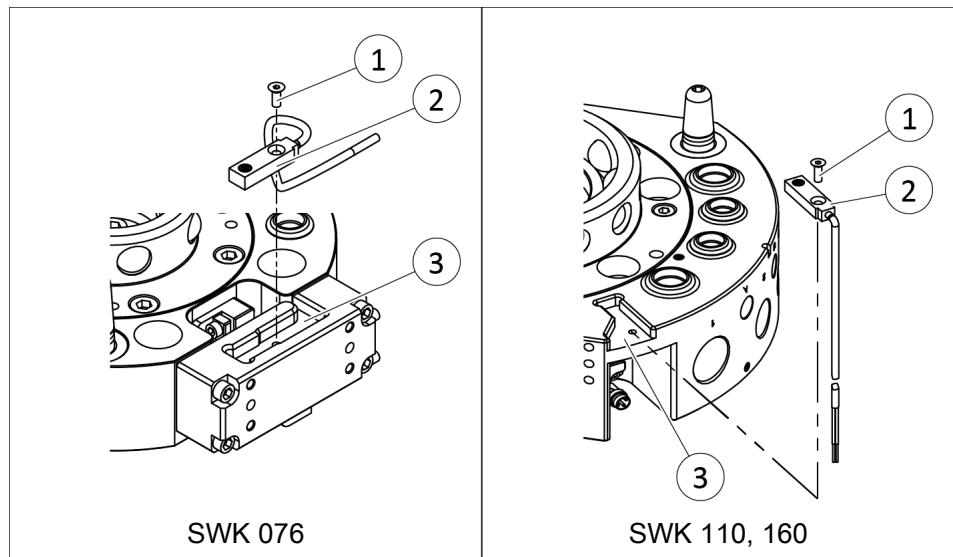

*Change sensor ready-to-lock*

1. Place the SWA in the storage rack, secure and uncouple it.
2. Disassemble the SWK from the robot and safely set the SWK aside, ▶ 7.4 [ 89].
3. Hold the ferromagnetic object against the sensor surface and test the presence monitoring LED.
4. Switch off the power supply and ensure that there is no residual energy in the system.
5. Remove the compressed air hose.
6. Loosen screw (1).
7. Remove sensor (2).
8. **Only for SWK 076:** Guide new sensor cable out from between mounting kit and SWK.
9. Apply screw lock to screw (1).
10. Fasten sensor (2) with screw (1) in recess (3).
  - ⇒ Max. tightening torque: 0.4 Nm
11. Hold the ferromagnetic object against the sensor surface and test the presence monitoring LED.

## 7.9 Maintain option modules

### 7.9.1 Clean electric feed-through module

#### NOTICE

#### Damage to pins and spring contacts possible!

Only use non-abrasive materials to clean the pin block, e.g. a nylon brush or a vacuum suction unit.

1. Place the SWA in the storage rack, secure and uncouple it.
2. Remove the compressed air hose.
3. Switch off the power supply and ensure that there is no residual energy in the system.
4. Disassemble the SWK from the robot and safely set the SWK aside, ▶ 7.4 [ 89].
5. Check pin block for deposits and blackened spring contacts.

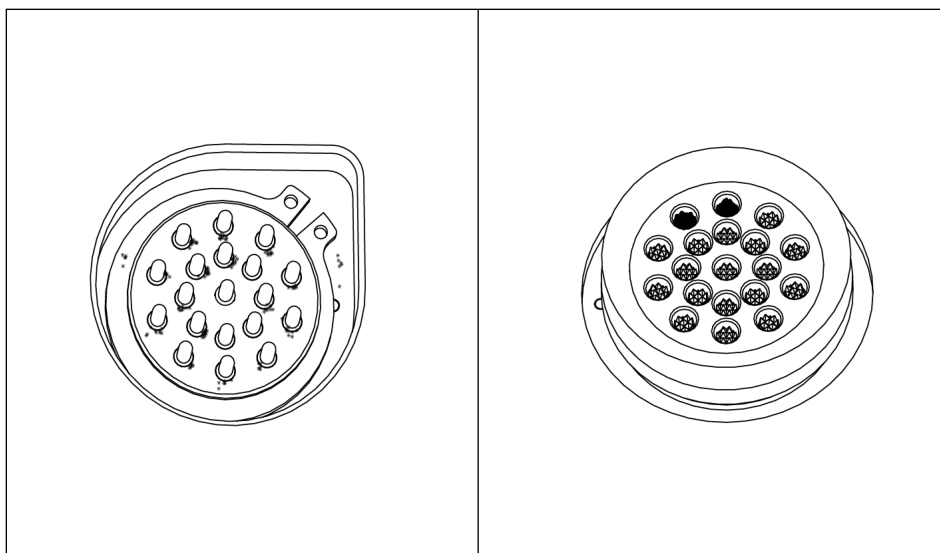

*Example illustration for deposits or blackened spring contacts on the pin block*

6. Remove deposits with a vacuum suction unit and clean pin block with a nylon brush.
7. After cleaning, check pin block for damage and wedged spring contacts.

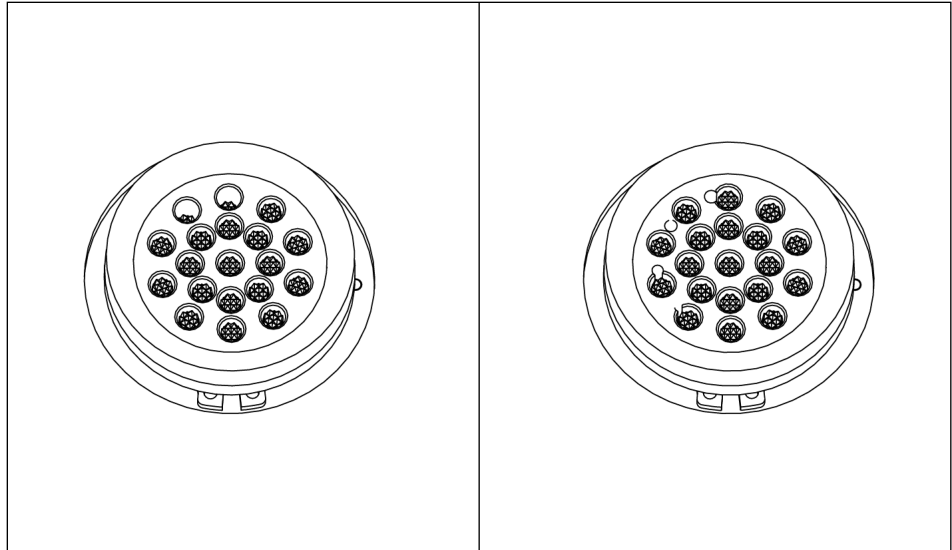

Example illustration for damage to the spring contacts

8. Loosen wedged spring contacts carefully by applying light pressure with a blunt tip.
9. Contact SCHUNK if the pins are damaged. Either individual pins can be exchanged or a new electric feed-through module is required.

### 7.9.2 Replace V-ring seal on electric feed-through module

1. Place the SWA in the storage rack, secure and uncouple it.
2. Switch off the power supply and ensure that there is no residual energy in the system.
3. Remove the compressed air hose.
4. Disassemble the SWK from the robot and safely set the SWK aside, ▶ 7.4 [ 89].



Remove and insert the seal of the electric feed-through module

5. Pull off the seal from the pin block.
6. Check seal for wear or damage.
7. Carefully pull the new seal apart with your fingers and pull it over the pin block.
8. Press the seal into the slot of the pin block.

### 7.9.3 Change rubber bushing on the fluid feed-through module

1. Place the SWA in the storage rack, secure and uncouple it.
2. Switch off the power supply and ensure that there is no residual energy in the system.
3. Remove the compressed air hose.
4. Disassemble the SWK from the robot and safely set the SWK aside, ▶ 7.4 [📄 89].

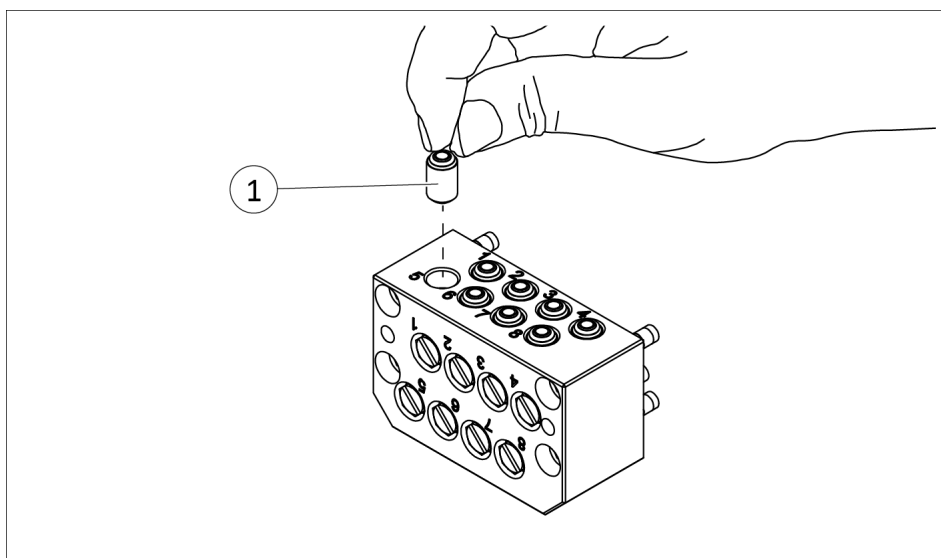

*Replace the rubber bushing of the fluid feed-through module*

5. Remove damaged rubber bushing (1).
6. Lightly lubricate the new rubber bushing (1), ▶ 7.3 [📄 88].
7. Carefully insert the rubber bushing (1) into the bore with the flat end up to the stop. The conical end points upwards.

## 7.10 Assembly drawings

### 7.10.1 SWS 001

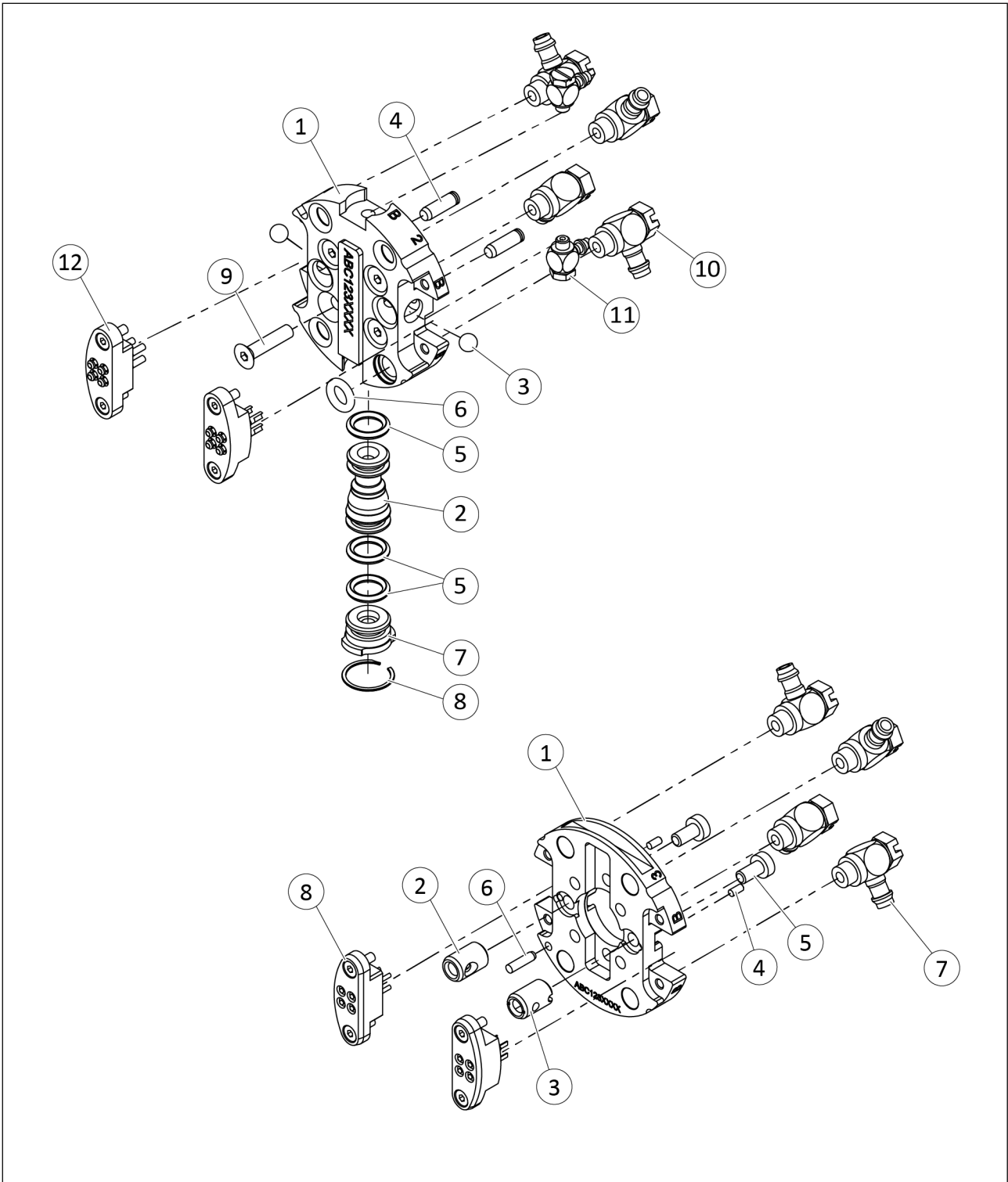

Assembly of SWK 001 (top) and SWA 001 (bottom)

7.10.2 SWS 005

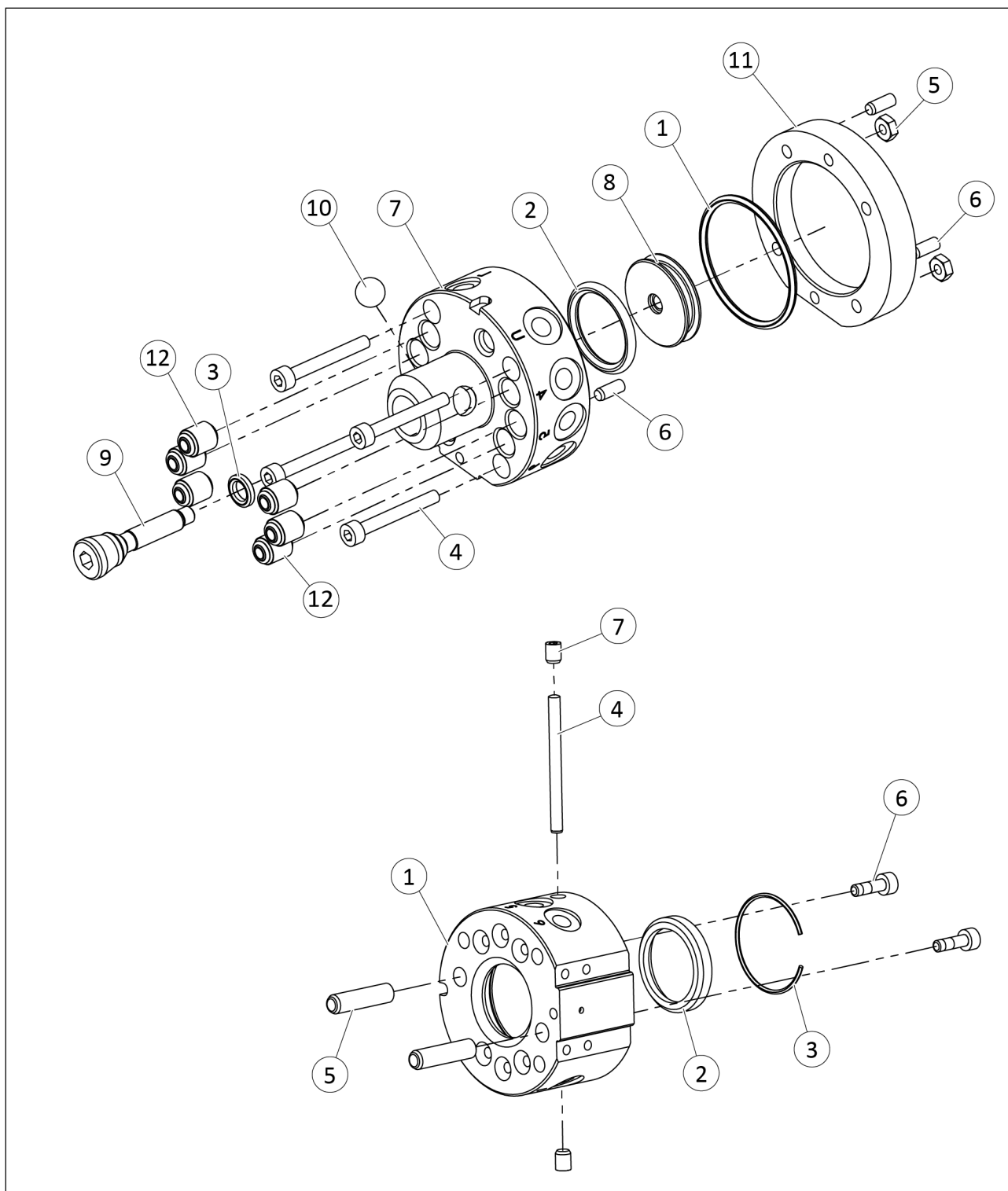

Assembly of SWK 005 (top) and SWA 005 (bottom)

### 7.10.3 SWS 007

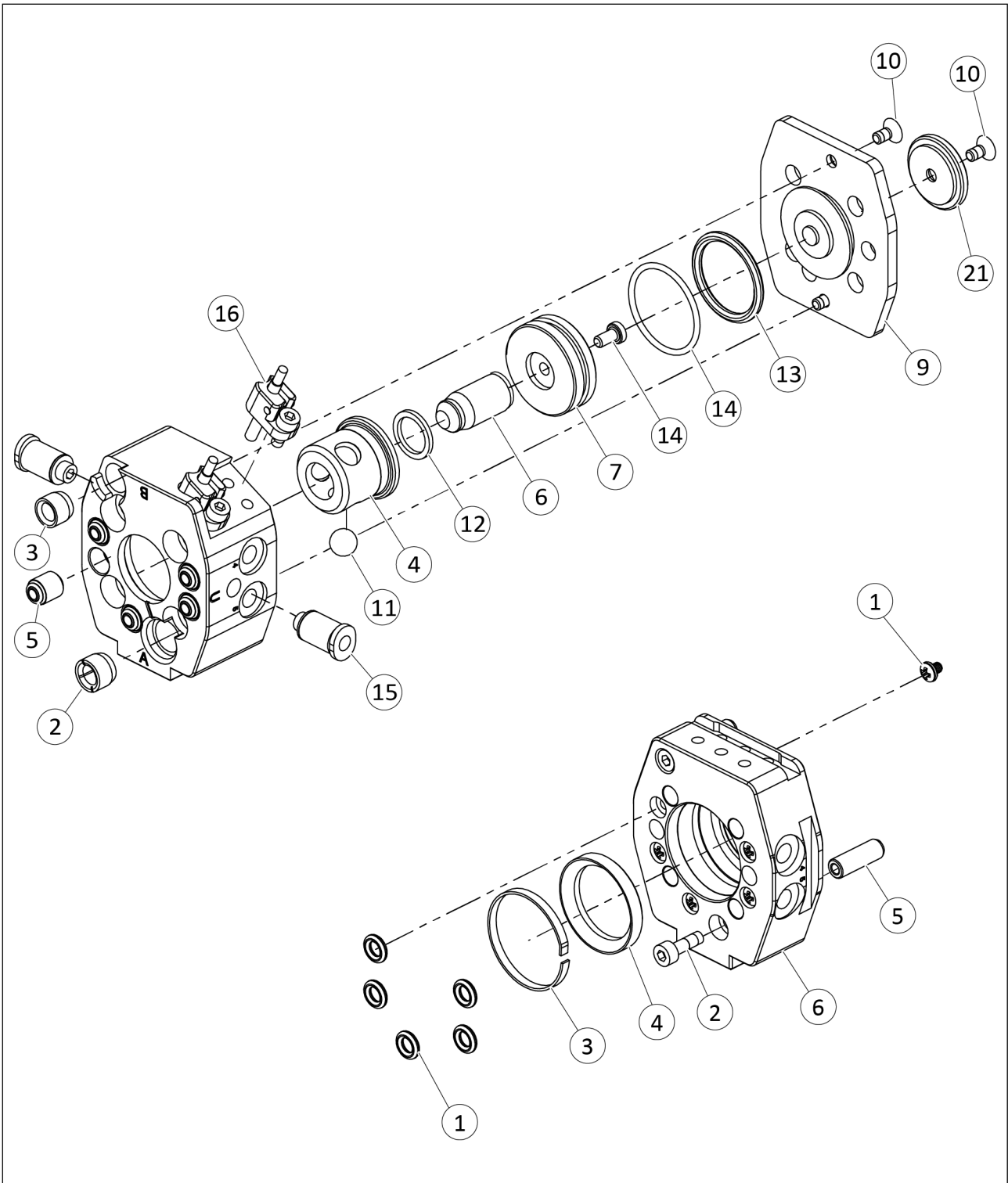

Assembly of SWK 007 (top) and SWA 007 (bottom)

7.10.4 SWS 011

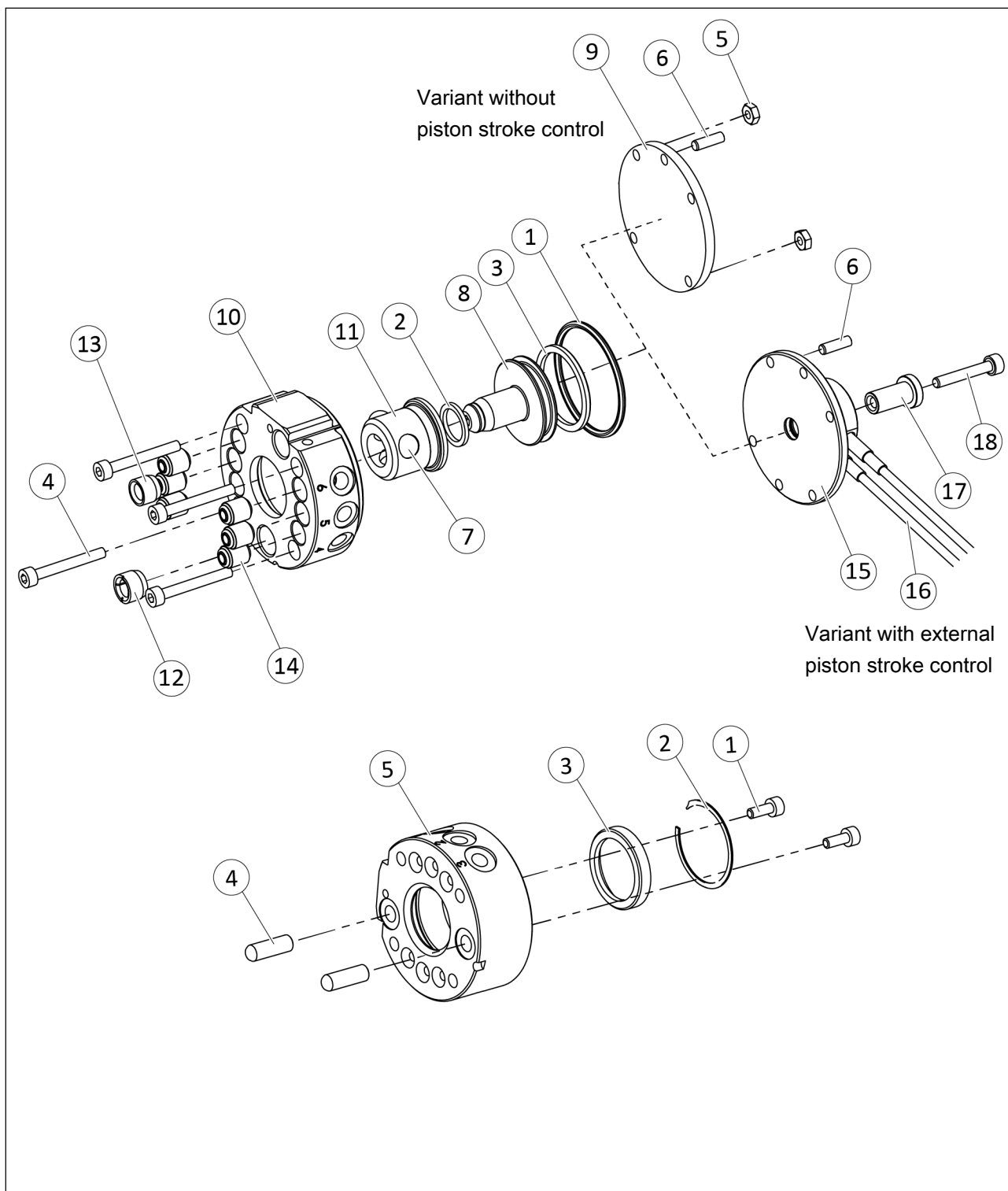

Assembly of SWK 011 (top) and SWA 011 (bottom)

### 7.10.5 SWS 011HM

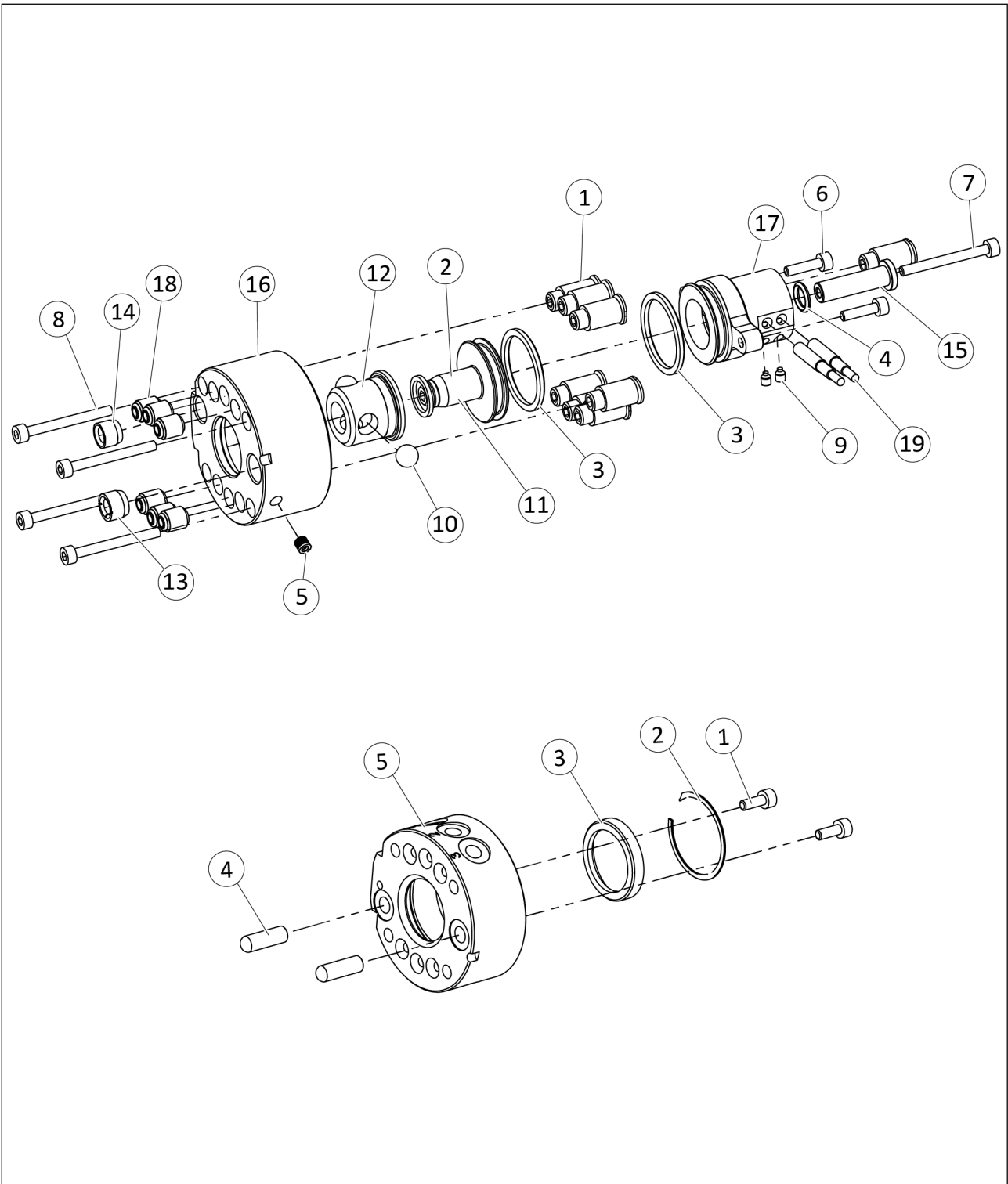

Assembly of SWK 011HM (top) and SWA 011 (bottom)

### 7.10.6 SWS 020

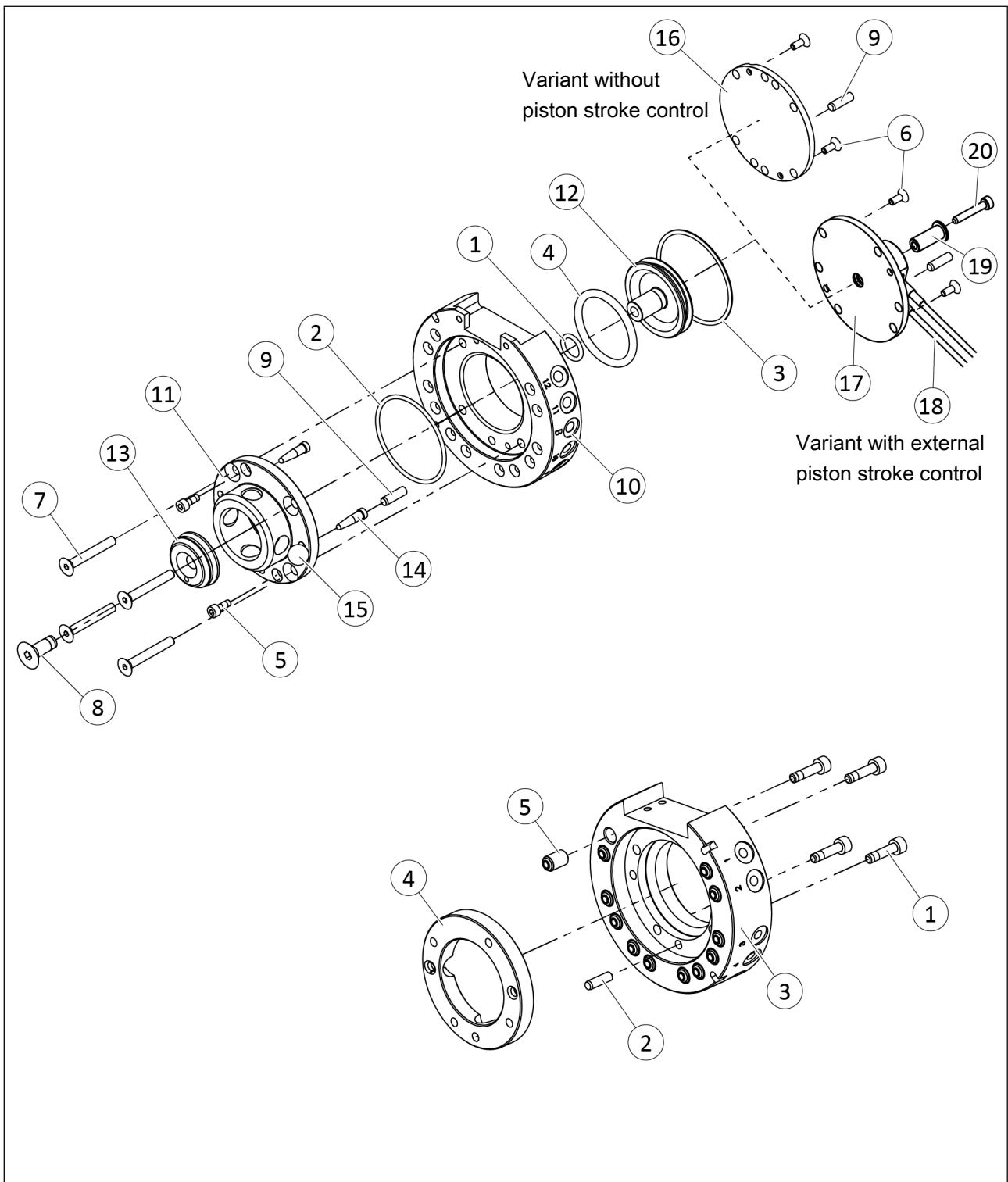

Assembly of SWK 020 (top) and SWA 020 (bottom)

### 7.10.7 SWS 020HM

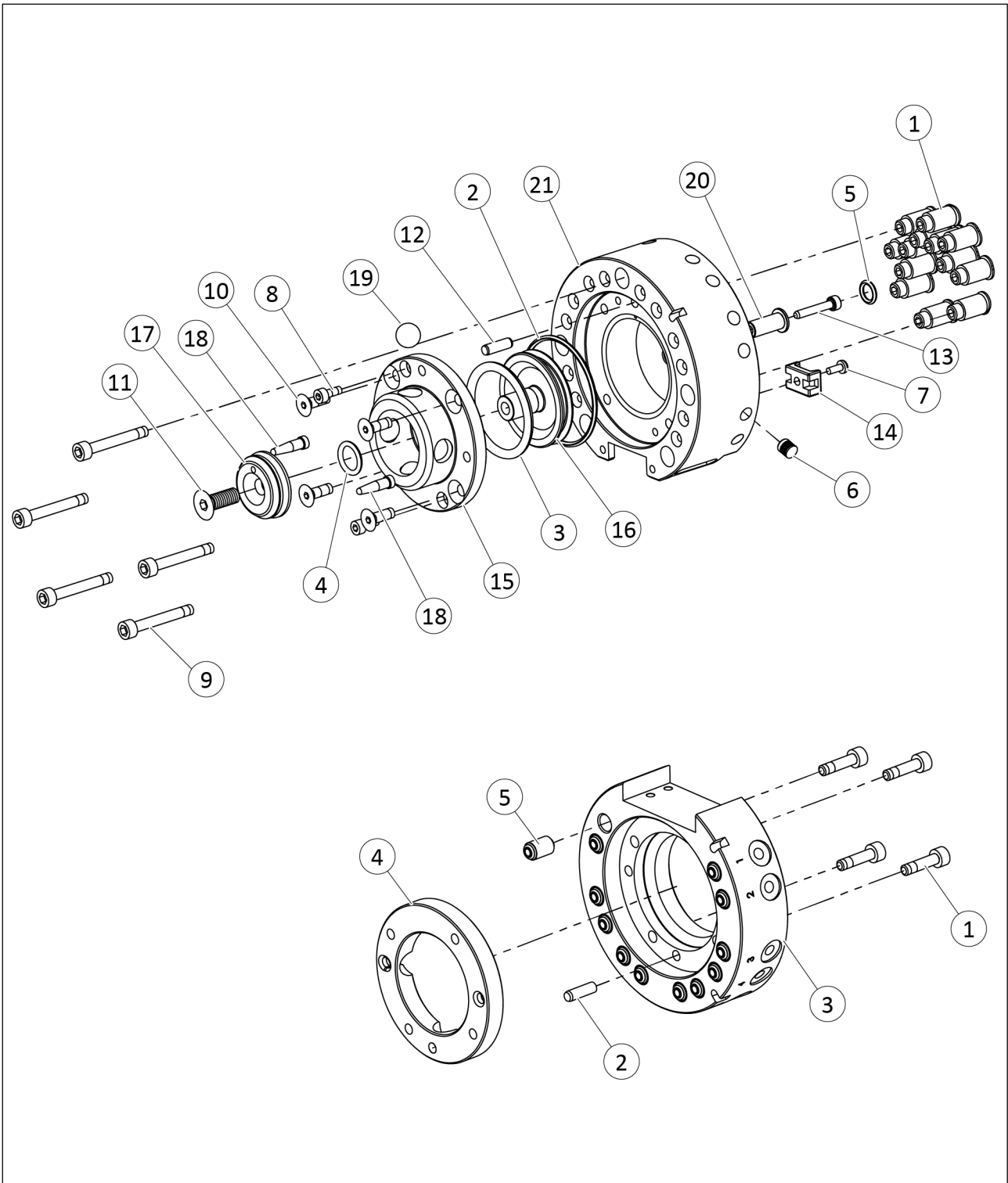

Assembly of SWK 020HM (top) and SWA 020 (bottom)

### 7.10.8 SWS 021

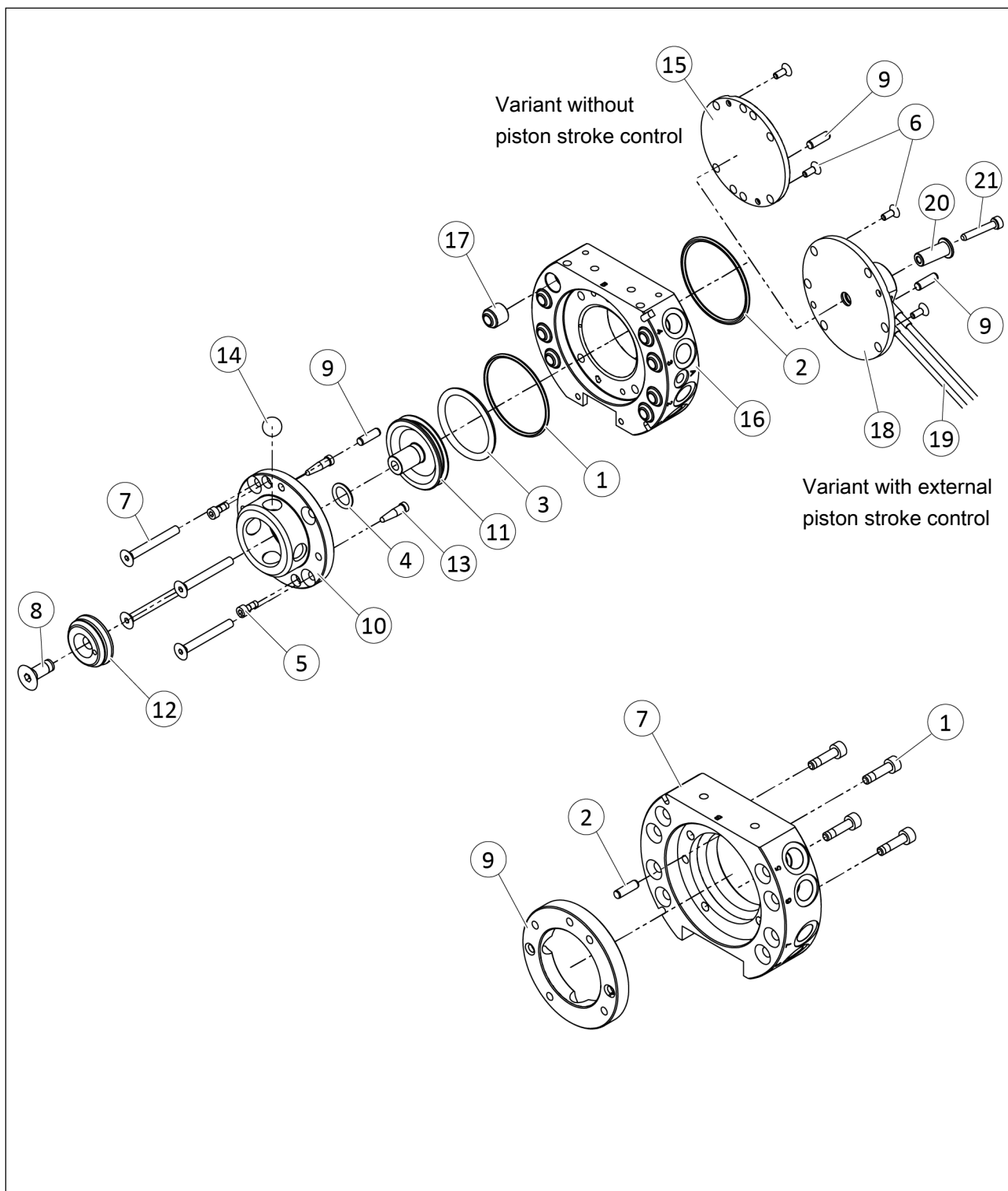

Assembly of SWK 021 (top) and SWA 021 (bottom)

### 7.10.9 SWS 021HM

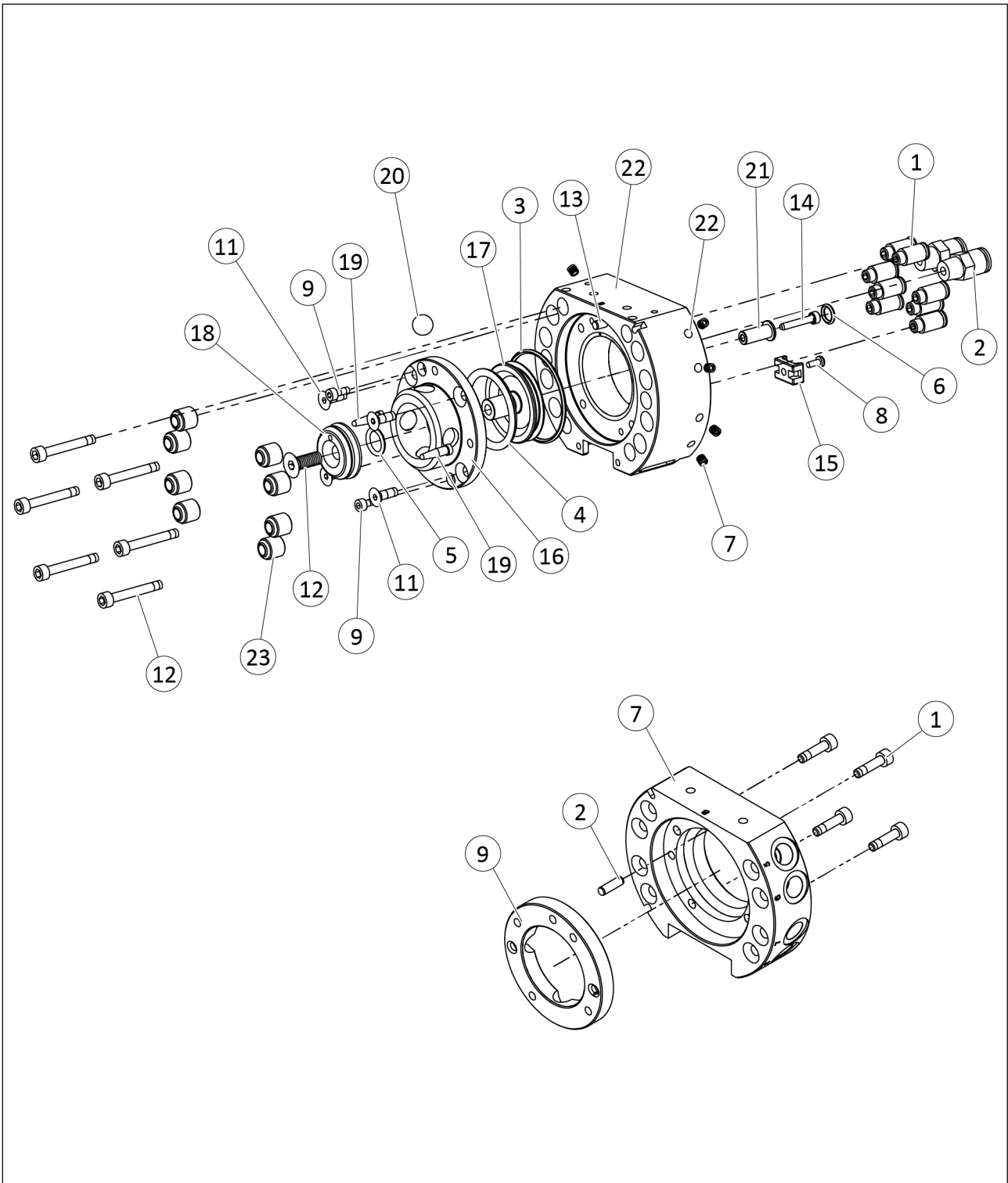

Assembly of SWK 021HM (top) and SWA 021 (bottom)



### 7.10.11 SWS 029

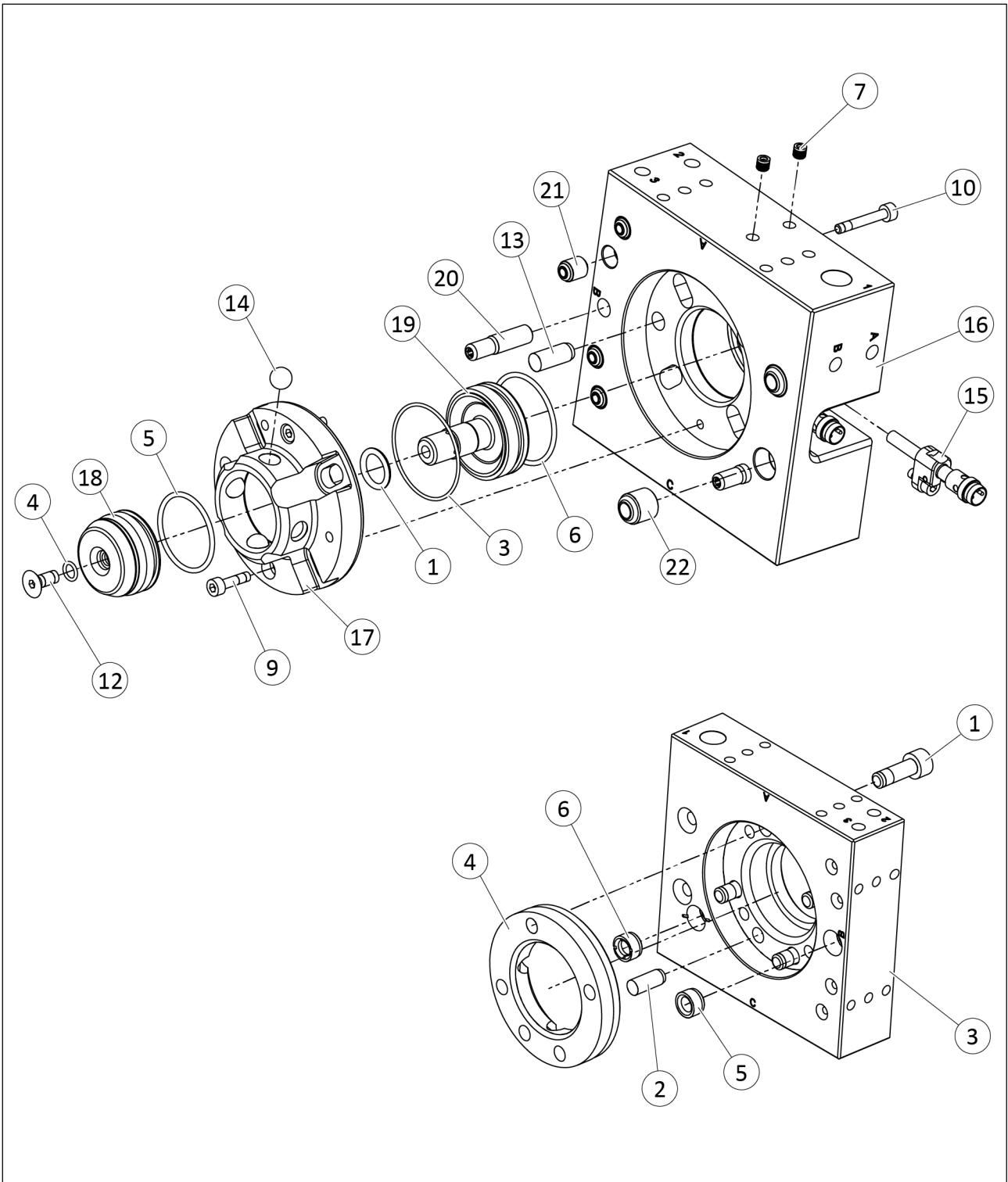

Assembly of SWK 029 (top) and SWA 029 (bottom)

### 7.10.12 SWS 040Q

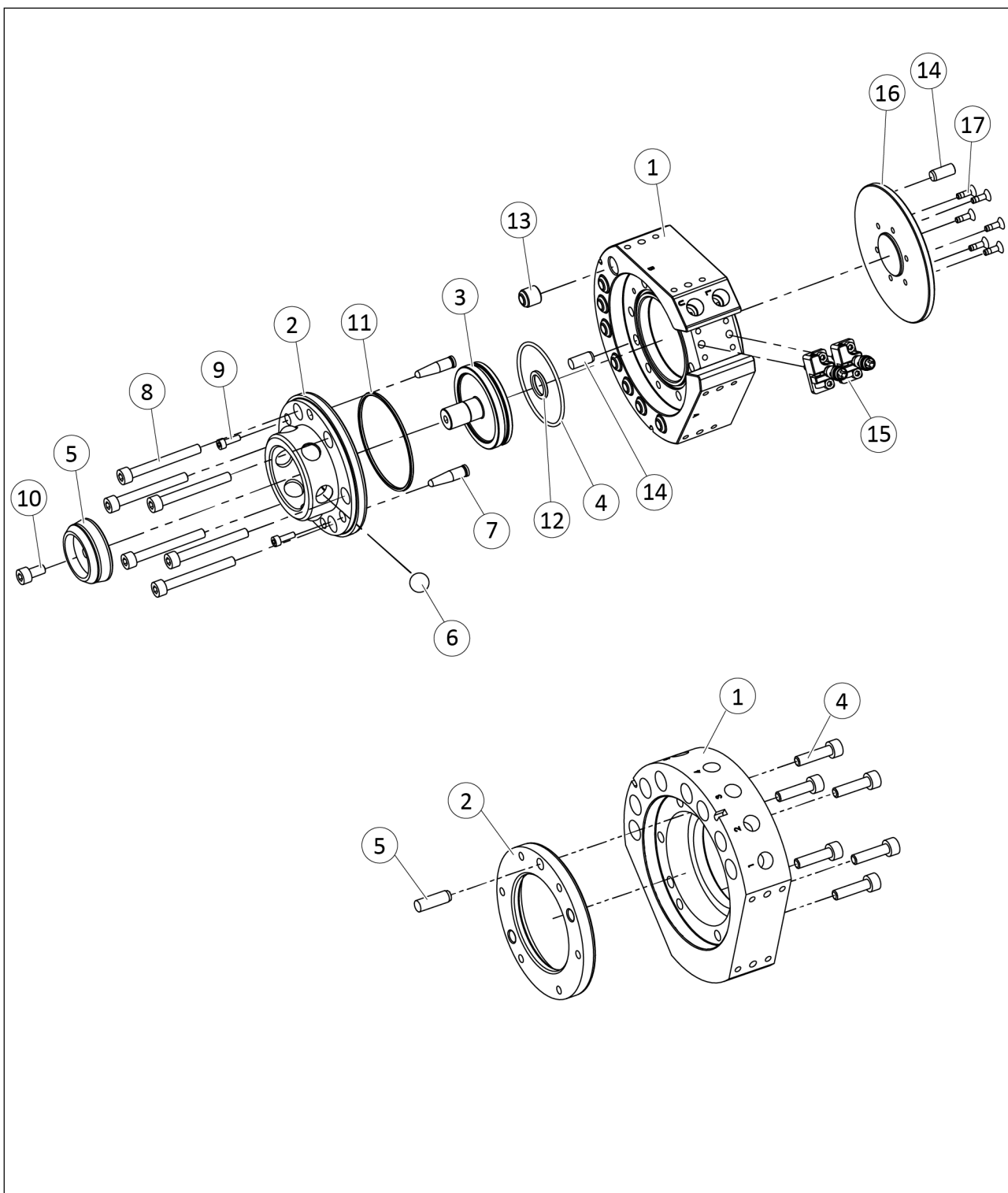

Assembly of SWK 040Q (top) and SWA 040Q (bottom)

### 7.10.13 SWS 041

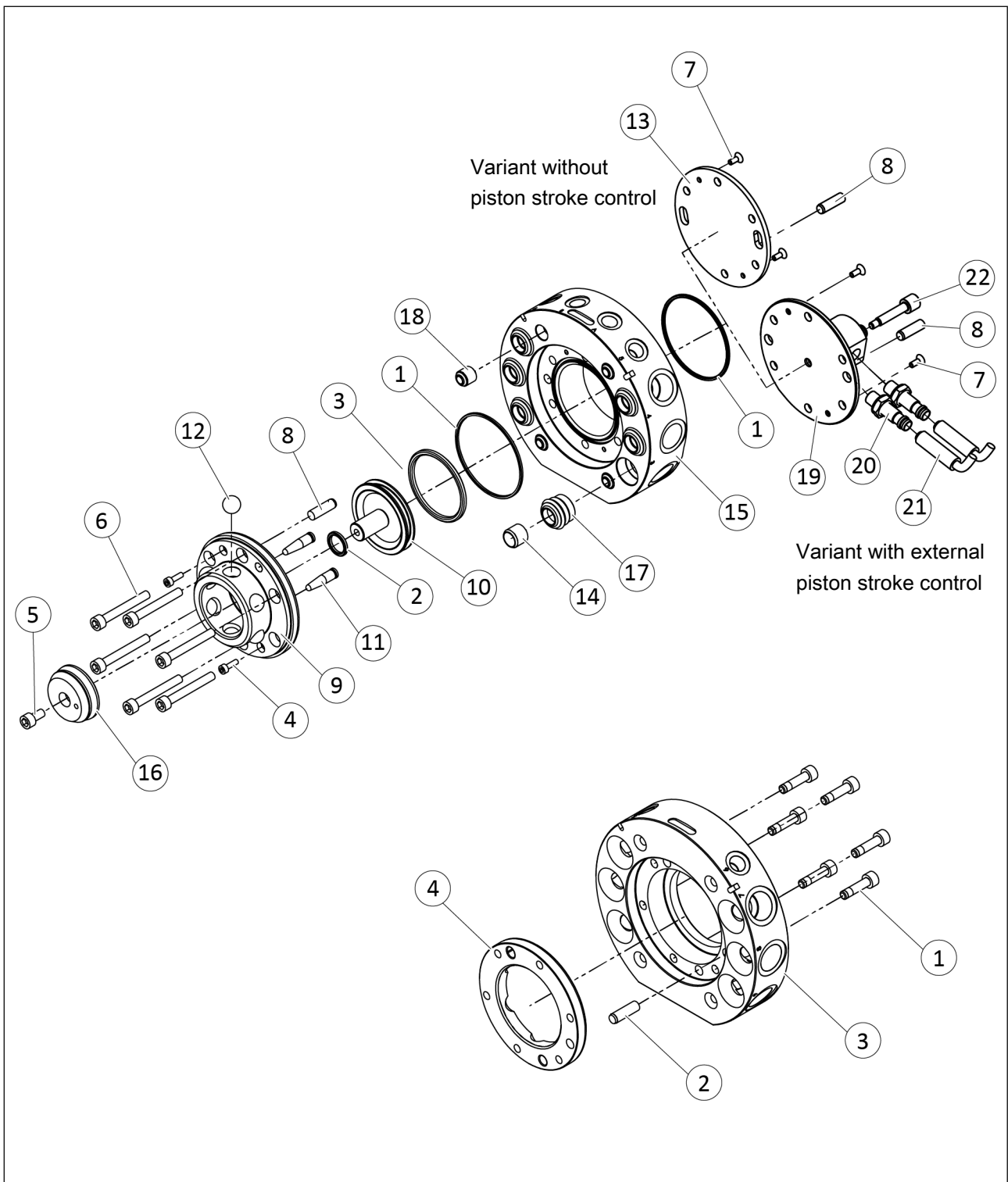

Assembly of SWK 041 (top) and SWA 041 (bottom)

### 7.10.14 SWS 046

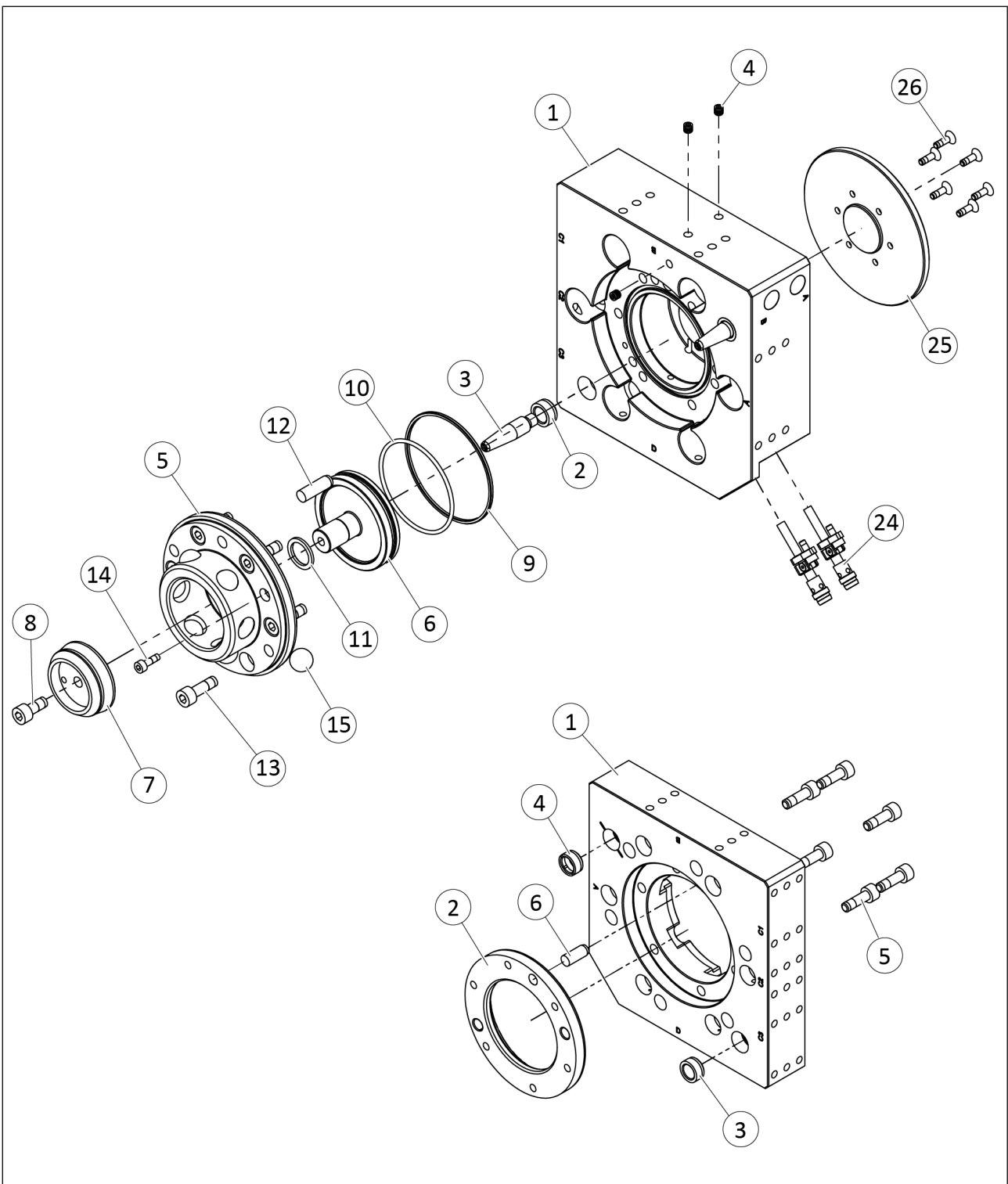

Assembly of SWK 046 (top) and SWA 046 (bottom)

### 7.10.15 SWS 060

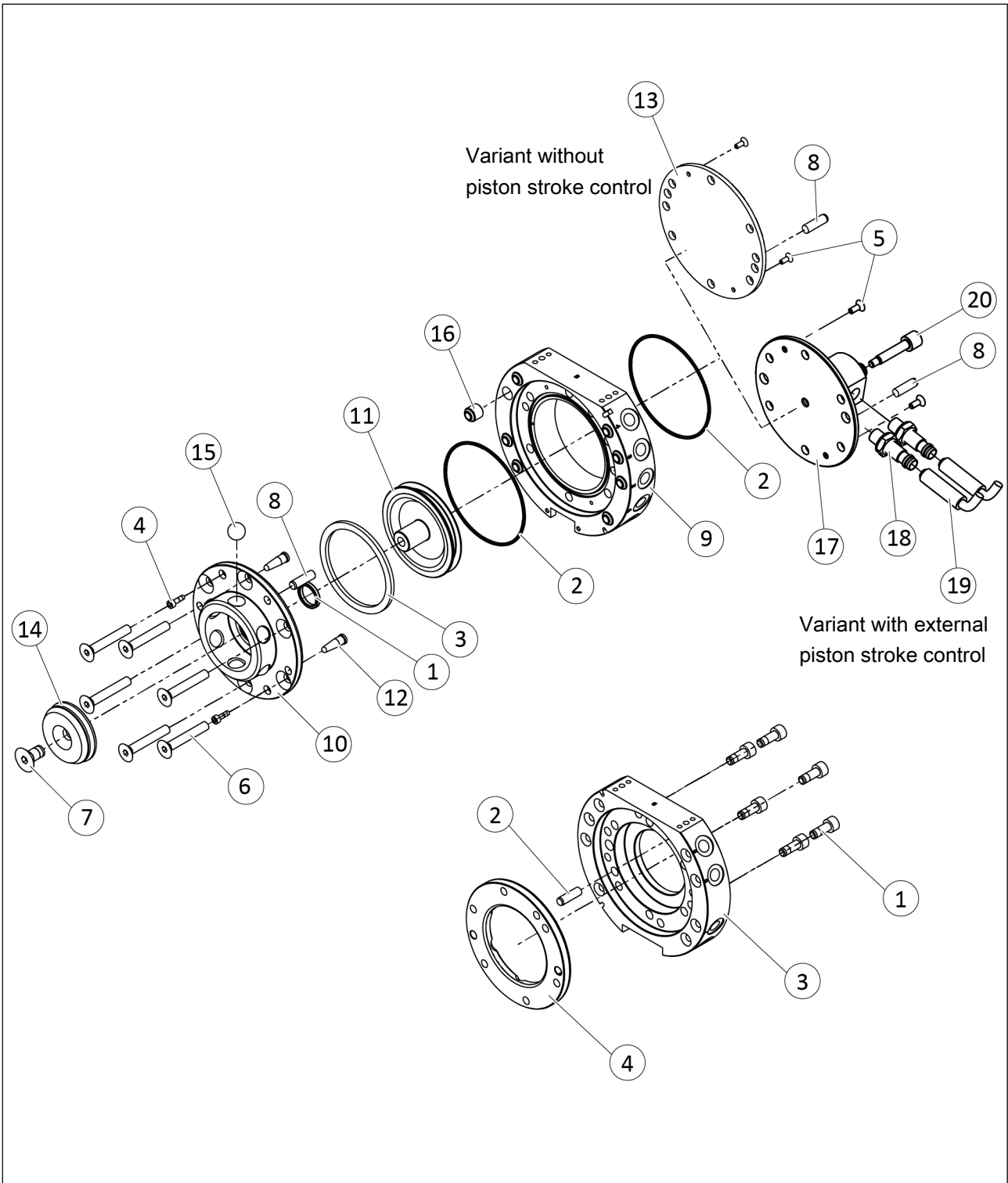

Assembly of SWK 060 (top) and SWA 060 (bottom)

7.10.16 SWS 071

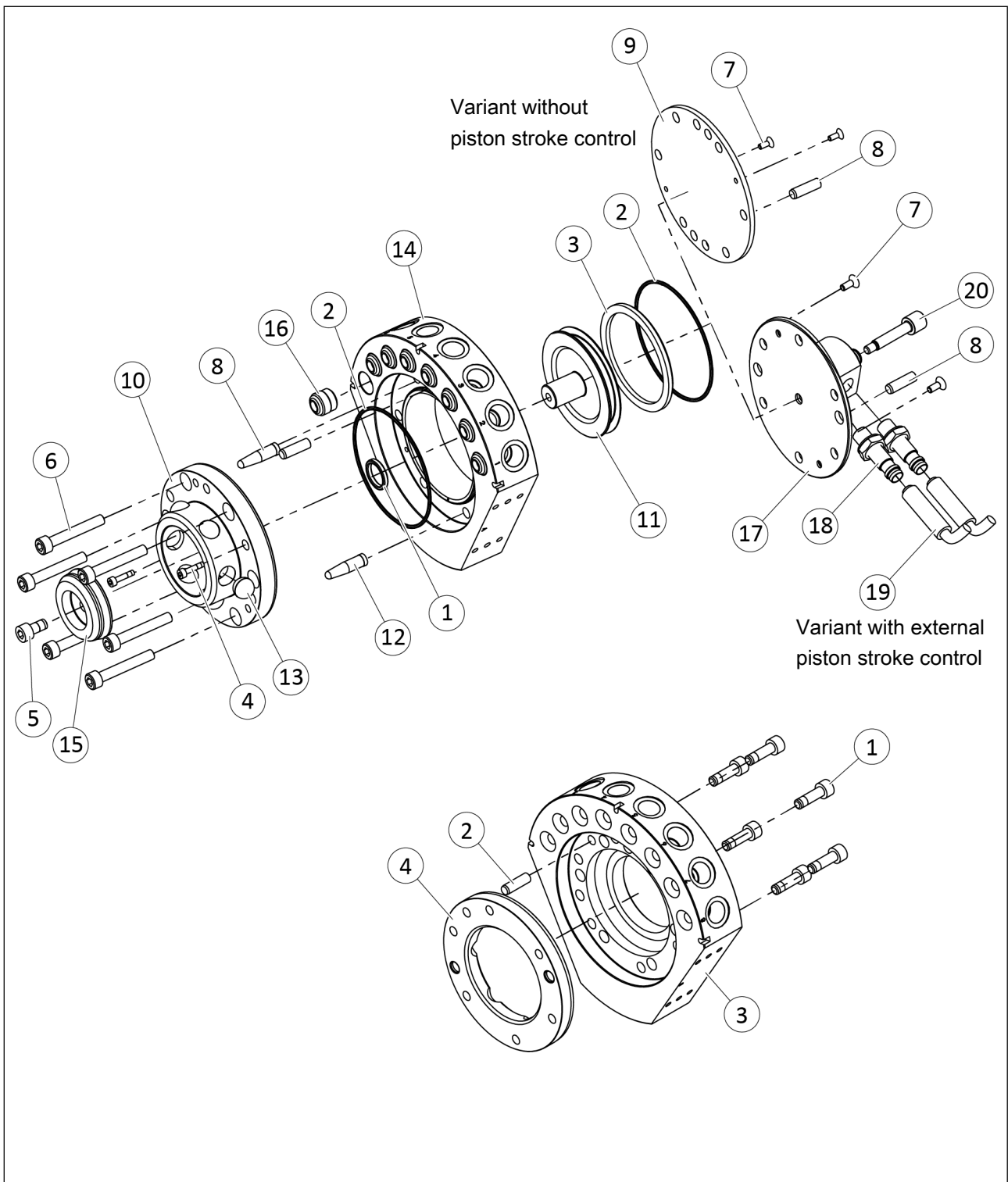

Assembly of SWK 071 (top) and SWA 071 (bottom)

### 7.10.17 SWS 076

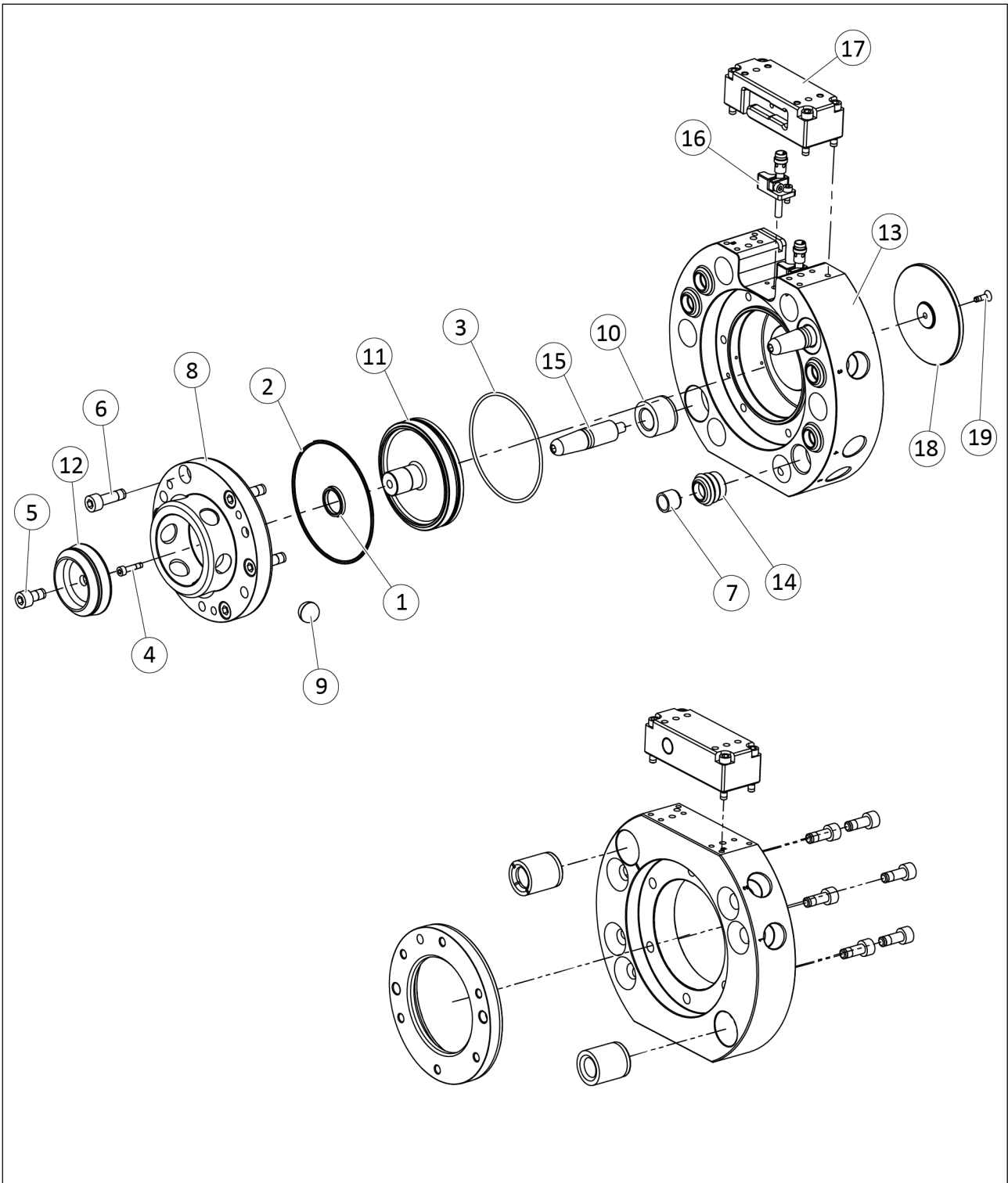

Assembly of SWK 076 (top) and SWA 076 (bottom)

7.10.18 SWS 110

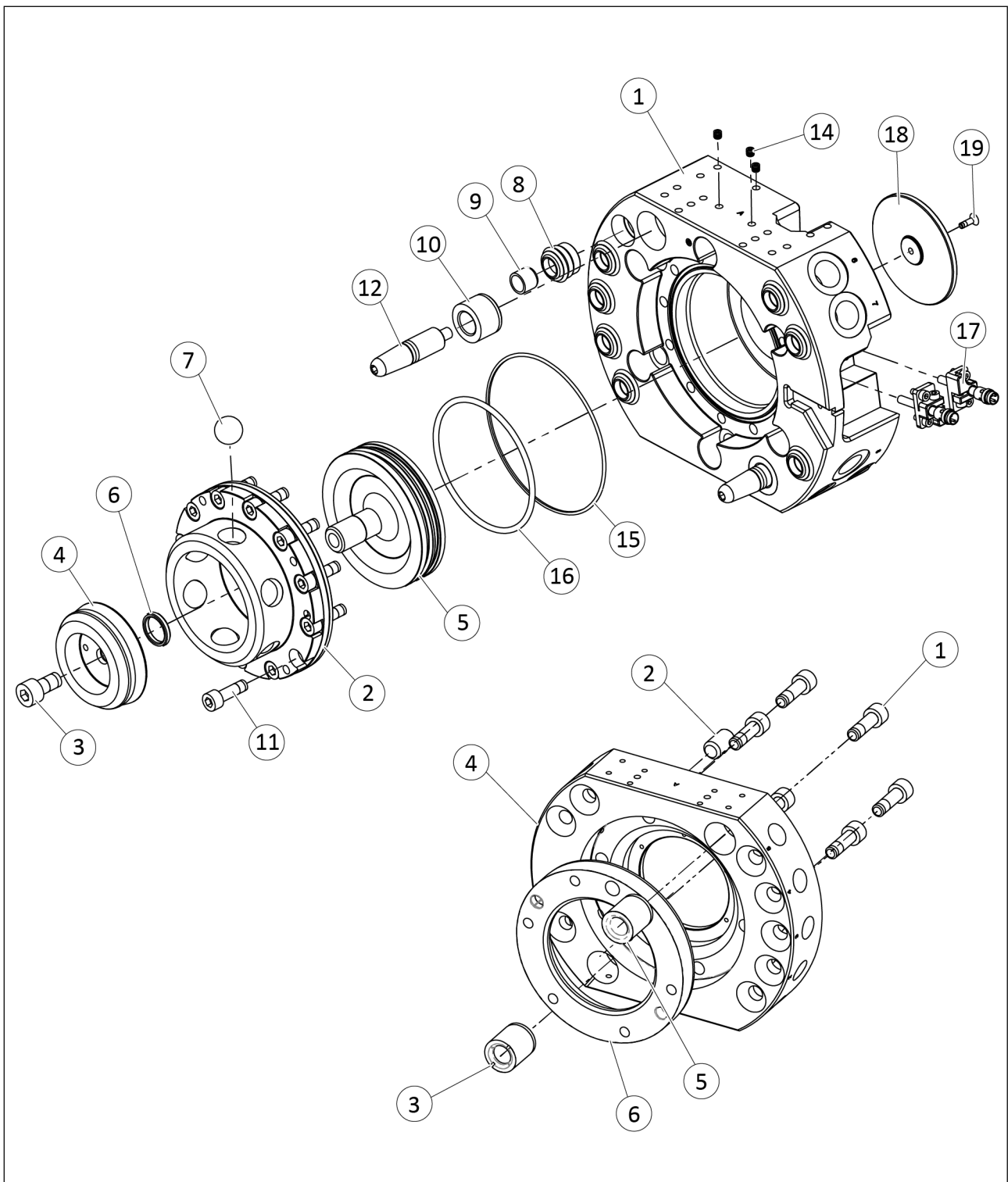

Assembly of SWK 110 (top) and SWA 110 (bottom)

### 7.10.19 SWS-160

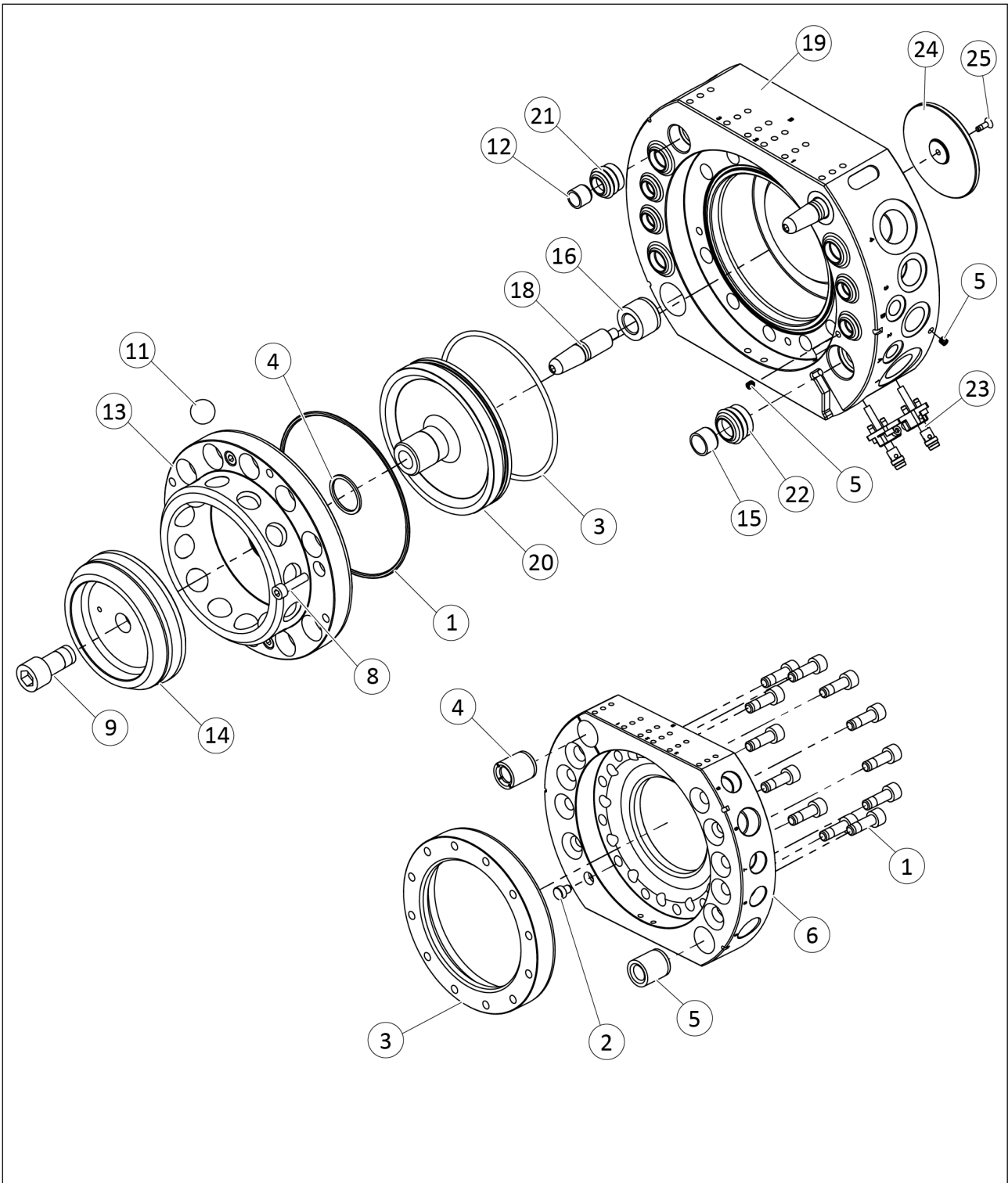

Assembly of SWK 160 (top) and SWA 160 (bottom)

## 8 Translation of the original declaration of incorporation

in terms of the Directive 2006/42/EG, Annex II, Part 1 Section B.

Manufacturer/  
Distributor                      SCHUNK SE & Co. KG  
Toolholding and Workholding | Gripping Technology | Automation  
Technology  
Bahnhofstr. 106 – 134  
D-74348 Lauffen/Neckar

We hereby declare that the partly completed machine described below

Product designation:              Quick-Change System / SWS /pneumatic  
ID number                              0302290, 0302291, 0302292, 0302293, 1405836, 1365513, 0302316,  
0302317, 0302322, 0302323, 0302326, 0302327, 1326008, 1326013,  
1499175, 1499191, 0302364, 0302343, 0302346, 0302347, 1330577,  
1315663, 0302362, 0302363, 0302370, 0302371, 0302392, 0302391,  
0302412, 0302411, 0302440, 0302441

meets the following basic occupational health and safety of the Machinery Directive 2006/42/EC:

No. 1.1.1, No. 1.1.2, No. 1.1.3, No. 1.1.5, No. 1.3.2, No. 1.5.3, No. 1.5.4, No. 1.5.6, No. 1.5.8, No. 1.5.10, No. 1.5.11, No. 1.5.13

The partly completed machinery may not be put into operation until it has been confirmed that the machine into which the partly completed machinery is to be installed complies with the provisions of the Machinery Directive (2006/42/EC). The declaration shall be rendered invalid if modifications are made to the product.

Applied harmonized standards, especially:

EN ISO 12100:2010                      Safety of machinery – General principles for design –  
Risk assessment and risk reduction

The special technical documentation according to Annex VII, Part B, belonging to the partly completed machine, has been created.

Person authorized to compile the technical documentation:  
Stefanie Walter, Address: see manufacturer's address

*Signature: see original declaration*

Lauffen/Neckar, February 2024

Dr.-Ing. Manuel Baumeister,  
Head of Systems Engineering,  
Technology & Innovation

## 9 UKCA declaration of incorporation

in accordance with the Supply of Machinery (Safety) Regulations 2008.

Manufacturer/  
Distributor                      SCHUNK Intec Limited  
                                                 Clamping and gripping technology  
                                                 3 Drakes Mews, Crownhill  
                                                 MK8 0ER Milton Keynes

We hereby declare that on the date of the declaration the following partly completed machine complied with all basic safety and health regulations found in the "Supply of Machinery (Safety) Regulations 2008".

The declaration shall be rendered invalid if modifications are made to the product.

Product designation:        Quick-Change System / SWS / pneumatic  
ID number                      0302290, 0302291, 0302292, 0302293, 1405836, 1365513, 0302316,  
                                                 0302317, 0302322, 0302323, 0302326, 0302327, 1326008, 1326013,  
                                                 1499175, 1499191, 0302364, 0302343, 0302346, 0302347, 1330577,  
                                                 1315663, 0302362, 0302363, 0302370, 0302371, 0302392, 0302391,  
                                                 0302412, 0302411, 0302440, 0302441

The partly completed machine may not be put into operation until it has been confirmed that the machine into which the partly completed machine is to be installed complies with the provisions of the "Supply of Machinery (Safety) Regulations 2008".

Applied harmonized standards, especially:

EN ISO 12100:2010              Safety of machinery – General principles for design –  
                                                 Risk assessment and risk reduction

The special technical documentation according to Annex VII, Part B, belonging to the partly completed machine, has been created.

Person authorized to compile the technical documentation:  
Marcel Machado, address: refer to manufacturer's address



Lauffen/Neckar, February 2024

Dr.-Ing. Manuel Baumeister,  
Head of Systems Engineering,  
Technology & Innovation

## 10 Information on the RoHS Directive, REACH Regulation and Substances of Very High Concern (SVHC)

### RoHS Directive

SCHUNK products are classified as "large-scale stationary installations" or as "large-scale stationary industrial tools" within the meaning of Directive 2011/65/EU and its extension 2015/863/EU "on the restriction of the use of certain hazardous substances in electrical and electronic equipment (RoHS)", or fulfill their intended function only as part of one. Therefore products from SCHUNK do not fall within the scope of the directive at this time.

### REACH Regulation

Products from SCHUNK fully comply with the regulations of Regulation (EC) No. 1907/2006 "concerning the Registration, Evaluation, Authorization and Restriction of Chemicals (REACH)" and its amendment 2022/477. SCHUNK attaches great importance to completely avoiding chemicals of concern to humans and the environment wherever possible.

Only in rare exceptional cases do SCHUNK products contain SVHC substances on the candidate list with a mass content above 0.1%. In accordance with Article. 33 (1) of Regulation (EC) No. 1907/2006, SCHUNK complies with its duty to "communicate information on substances in articles" and lists the components concerned and the substances used in an overview that can be viewed at [schunk.com/SVHC](https://schunk.com/SVHC).

*Signature: see original declaration*

Lauffen/Neckar, February 2024

Dr.-Ing. Manuel Baumeister,  
Head of Systems Engineering,  
Technology & Innovation

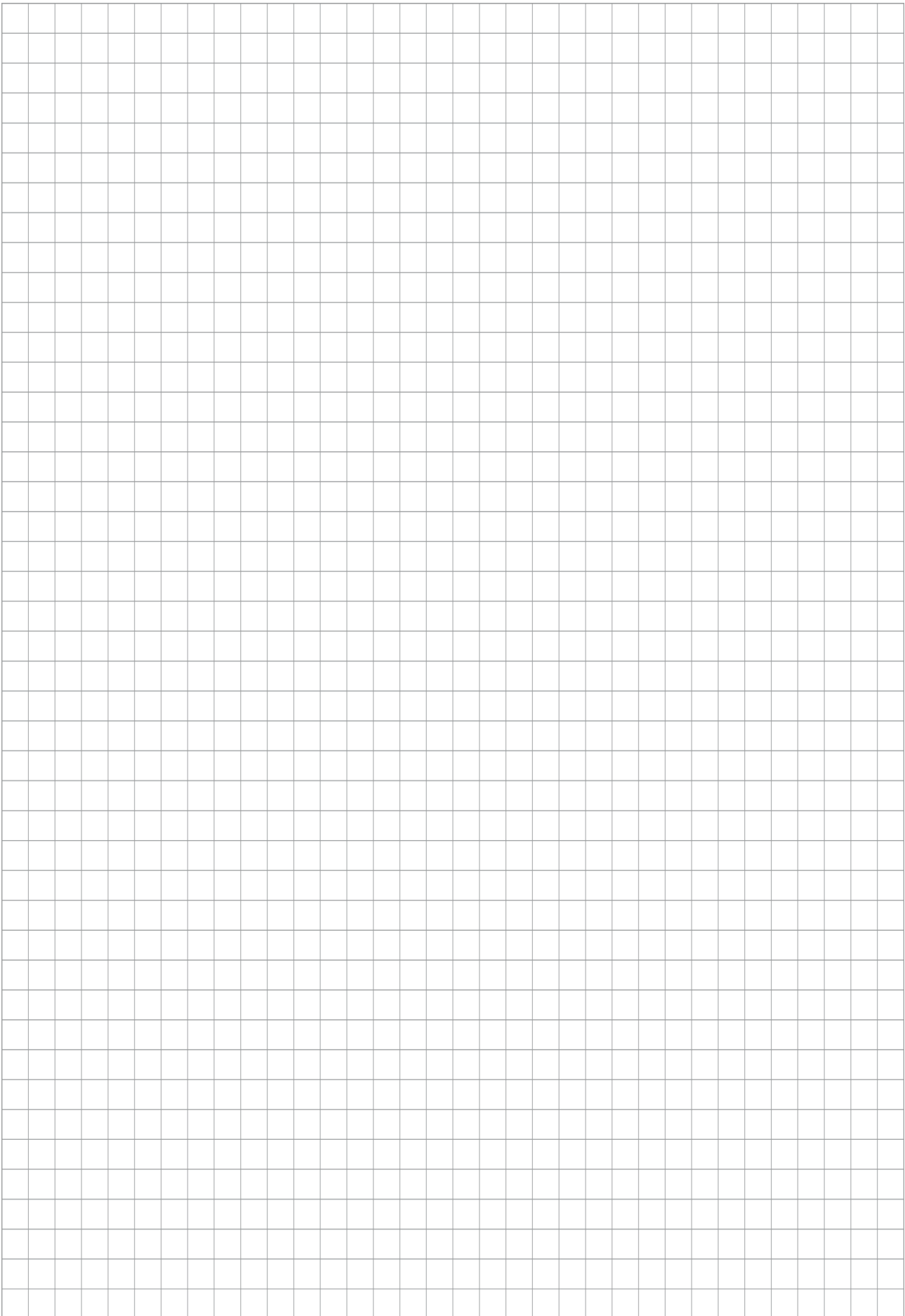

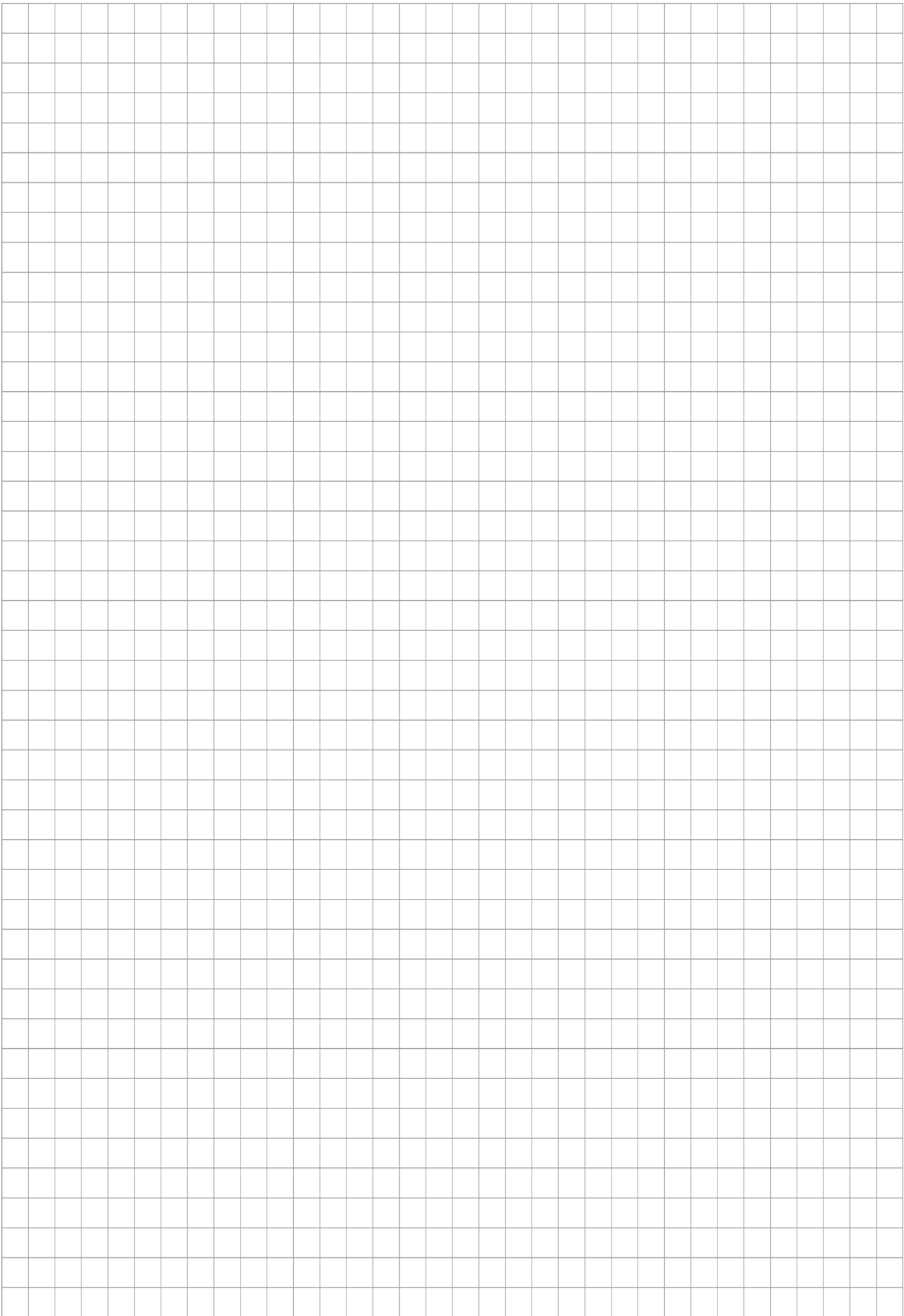



**SCHUNK SE & Co. KG**  
Toolholding and Workholding | Gripping Technology |  
Automation Technology

Bahnhofstr. 106 – 134  
D-74348 Lauffen/Neckar  
Tel. +49-7133-103-0  
info@de.schunk.com  
schunk.com

Folgen Sie uns | *Follow us*



Wir drucken nachhaltig | *We print sustainable*