

Control Unit

KEH-P / ECG-C/ FORCE.DIN

Assembly and Operating Manual



Legal notices:

Copyright:

This manual remains the copyrighted property of SCHUNK GmbH & Co. KG. It is solely supplied to our customers and operators of our products and forms part of the unit. This documentation may not be duplicated or made accessible to third parties, in particular competitive companies, without our prior permission.

Technical changes:

We reserve the right to make alterations for the purpose of technical improvement.

Document number: 5034707 [ex QM.UC.00002]

Edition: 1.0 | 15/03/2022 | en

© H.-D. SCHUNK GmbH & Co. Spanntechnik KG

All rights reserved

Dear customer,

congratulation on choosing a SCHUNK product. By choosing SCHUNK, you have opted for the highest precision, top quality and best service.

You are going to increase the process reliability of your production and achieve best machining results – to the customer's complete satisfaction.

SCHUNK products are inspiring.

Our detailed assembly and operation manual will support you.

Do you have further questions? You may contact us at any time – even after purchase.

Kindest Regards

H.-D. SCHUNK GmbH & Co. Spanntechnik KG

Lothringer Str. 23

88512 Mengen

Deutschland

Tel. +49-7572-7614-0

Fax +49-7572-7614-1099

info@de.schunk.com

www.schunk.com



Reg. No. 003496 QM08



Reg. No. 003496 QM08

Table of contents

1	About this manual	4
1.1	Warnings.....	4
1.1.1	Signal words	4
1.1.2	Symbols	4
2	Basic safety notes	5
2.1	Intended use.....	5
2.2	Environmental and operating conditions.....	5
2.3	Product safety.....	6
2.3.1	Protective equipment	6
2.4	Personnel qualification.....	6
2.5	Use of personal protective equipment	7
2.6	Notes on particular risks.....	7
3	Warranty	8
4	Scope of delivery	9
5	Technical Data	10
5.1	Identification plate	11
5.2	Dimensions	12
6	Installation	14
7	Initial commissioning and normal operation	16
7.1	Initial commissioning.....	16
7.2	Normal operation	18
8	Troubleshooting	20
9	Servicing and maintenance	21
10	Storage	22
11	Disposal	23
12	Spare parts	24

1 About this manual

This instruction is an integral part of the product and contains important information for a safe and proper installation, commissioning, operation, maintenance and helps for an easier trouble shooting.

Before using the product, read and note the instruction, especially the chapter "Basic safety notes".

1.1 Warnings

The following signal words and symbols are used to highlight dangers.

1.1.1 Signal words

DANGER	Dangers for persons. Non-compliance will inevitably cause irreversible injury or death.
WARNING	Dangers for persons. Non-compliance may cause irreversible injury or death.
CAUTION	Dangers for persons. Non-observance may cause minor injuries.
ATTENTION	Information about avoiding material damage

1.1.2 Symbols



Warning about a danger point



Warning about dangerous electrical voltage



Danger of magnetic field



Danger of falling down workpieces



General mandatory sign to prevent material damage

2 Basic safety notes



2.1 Intended use

This control unit has exclusively been designed for the operation of SCHUNK electro-permanent magnetic chucks, during the use of which it is essential, that the time between two ON/OFF cycles is not less than 3 minutes.

This control unit has furthermore been designed for the installation inside the electrical cabinet (which can only be opened by means of appropriate tools) of machine tools for the clamping and machining of workpieces and must operate in dry interiors with a relative air humidity of 5-15 % (max. 50% at 40°, without condensation) and an ambient temperature of 5°-40°C.

The requirements of the applicable standards must be observed. The control unit may only be used in the context of its defined application parameters.

For its intended use it is also essential to observe the technical data, the installation and operation notes as well as the maintenance intervals indicated in the present manual.

	 DANGER
	<p>Danger to short circuit</p> <ul style="list-style-type: none"> • The control unit must be installed inside the electrical cabinet of the machine tool and must always be protected against water and/or operating fluids from the machine and protected against metal chips.

NOTE

This control unit **must not** be placed in service until the machine tool, for which the controller is provided, satisfies the requirements of the Machinery Directive 2006/42/EC!!

2.2 Environmental and operating conditions

- Use the control unit only within its defined application parameters. "Technical data" ([↗ 5, Page 10](#)).
- Make sure that the environment is clean and the ambient temperature corresponds to the specifications.

2.3 Product safety

Dangers arise from the control unit, if e.g.:

- the control unit is not used in accordance with its intended purpose.
- the control unit has not been installed or maintained properly.
- the safety and installation notes have not been observed.

Avoid any manner of working that may interfere with the function and operational safety of the control unit.

Wear protective equipment.

NOTE



More information is contained in the relevant chapters.

2.3.1 Protective equipment

Provide safety devices according to the EC Machinery Directive.

2.4 Personnel qualification

Installation, first commissioning, maintenance, and repair of the control unit may be performed by trained qualified personnel, only. Any person called upon by the operator to work on the control unit must have read and understood the complete installation and operating manual especially the chapter "Basic safety notes" ([↩ 2, Page 5](#)). This applies particularly to personnel used only occasionally, such as maintenance personnel.

	 DANGER
	<p>Danger due to a magnetic field. This control unit always uses a magnetic system. The following groups of persons must not come into contact with it:</p> <ul style="list-style-type: none">• Persons with pacemakers.• Persons with metal or electronic prostheses.• Persons with insulin pumps.• Persons with muscular stimulation systems.• Pregnant women.• These persons should always keep a safe distance of at least 2m from the magnetic system.

2.5 Use of personal protective equipment

When using this product, observe the relevant industrial safety regulations and use the personal protective equipment (PPE) required!

- Use protective gloves, safety shoes and safety goggles.
- Observe safe distances.
- Minimal safety requirements for the use of equipment.

2.6 Notes on particular risks

- Remove the energy supplies before installation, modification, maintenance, or adjustment work.
- Ensure that no residual energy remains inside the system.
- Perform maintenance, modifications, and additions outside the danger zone.
- For all work, secure the control unit against accidental operation.

3 Warranty

The warranty is valid for 12 months from the delivery date to the production facility under the following conditions:

- Intended use in 1-shift operation
- Observe the mandatory maintenance intervals.
- Observe the environmental and operating conditions.

Parts touching the work piece and wearing parts are not part of the warranty.

Procedure in the event of warranty The buyer agrees to send a written detailed report on newly discovered defects of the control unit to SCHUNK within 10 days after identification.

4 Scope of delivery

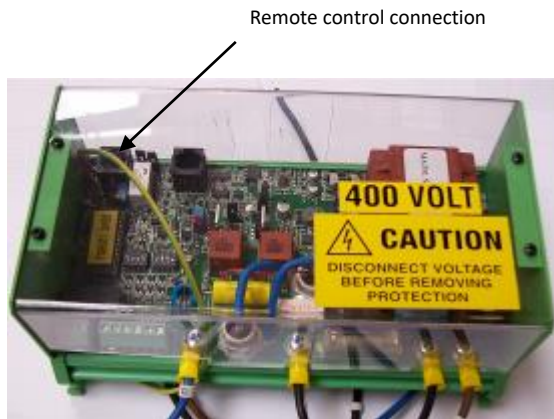
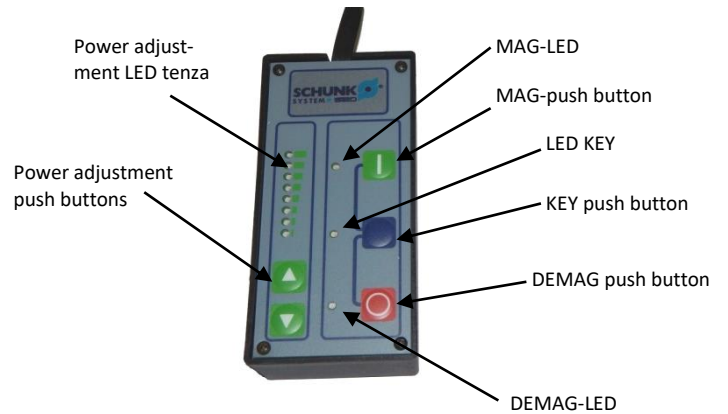

Fig. 1



The scope of delivery includes:

- Control unit
- Remote control (supplied as standard on the KEH-P series, on request for all other types)

5 Technical Data

Type	KEH.P / ECG-C / FORCE.DIN
Mains voltage	200 – 230 – 400 – 460 (VAC)
Frequency	50Hz / 60Hz
Phases	2 + PE
Rated current	32 A
Rated short circuit current	6 kA
Breaking current of the fuse for the auxiliary cir-cuit	500 mA at 500 V AC
IP rating	Respective IP protection at customer's care
Activation time	>0.3s at cycle 3; < 8s at cycle 8
Activation change	depending on the magnetic chuck
Weight	~ 2 kg
Ambient temperature	5° - 55° C
Ambient conditions	Operation in dry interiors with a maximum relative air humidity of 50%. Protect product from caustic vapours and excessive heat.

5.1 Identification plate

The identification plate is placed on the control unit cover:

Id.No.		Type		 H.-D. SCHUNK GmbH & Co. Spanntechnik KG Lothringer Str. 23 D-88512 Mengen Tel. +49-7572-7614-1301 Fax +49-7572-7614-1039 spannsysteme@de.schunk.com schunk.com
Serial No.		Work No.		
Voltage		Frequency		
Channels		Phases		
Current		Icc		
Year		Weight		
Main Document				

Fig. 2

Information	Description
Id. No.	Product code no.
Type	Model
Serial No.	Product serial no.
Work No.	Product production no.
Voltage	Rated voltage (mains)
Frequency	Rated frequency (mains)
Channels	Number of output channels
Phases	Phases (mains)
Current	Rated current (mains)
Icc	Rated short-circuit data
Year	Year of manufacture
Weight	Weight

The identification plate must never be removed! Please always have the serial no. at hand when contacting SCHUNK about technical matters.

5.2 Dimensions

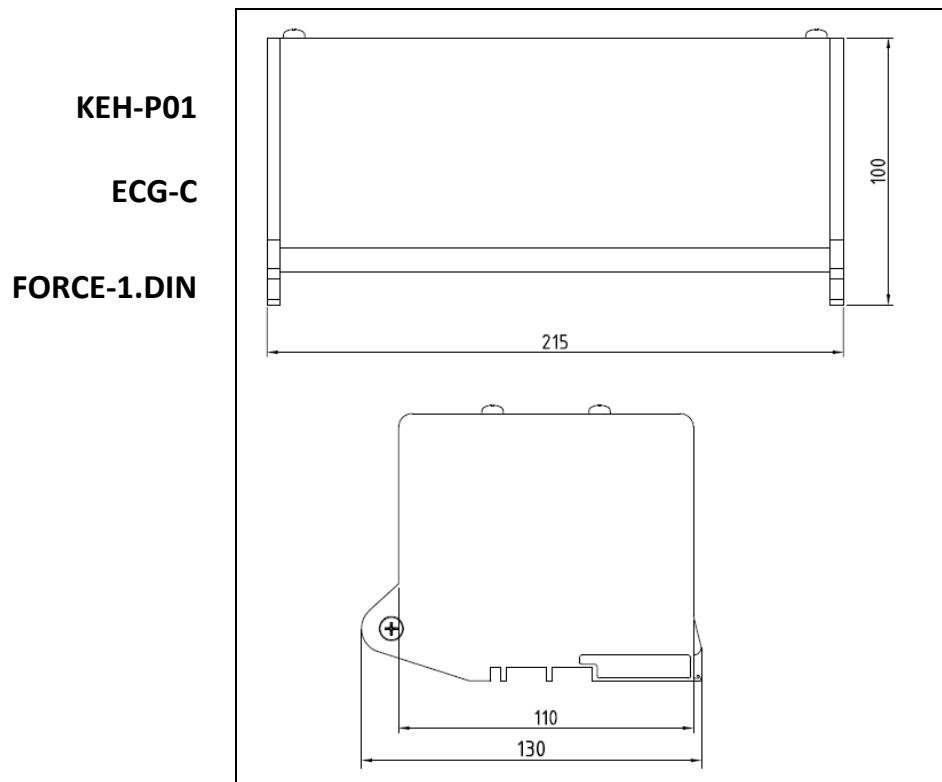

Fig. 3 Dimensions ECG-C, KEH.P01, FORCE-1.DIN

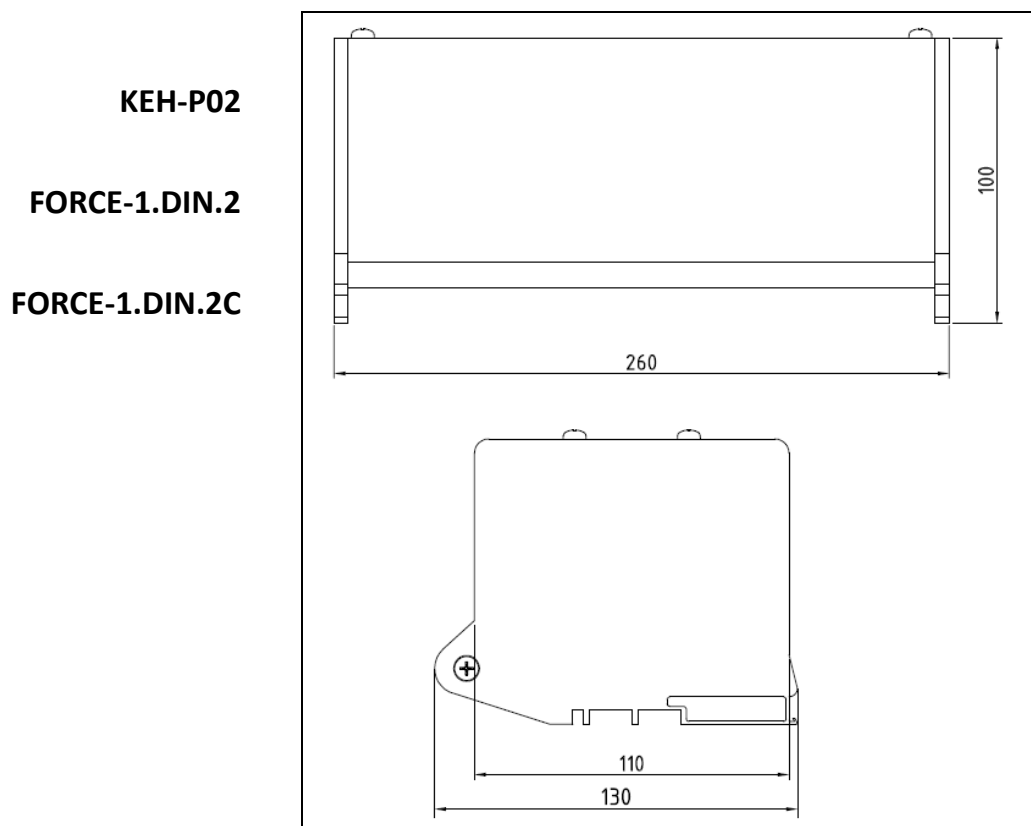

Fig. 4 Dimensions KEH-P02, FORCE-1.DIN2

KEH-P03-P08
 FORCE-1.DIN.4
 FORCE-1.DIN.3C
 FORCE-1.DIN.4C

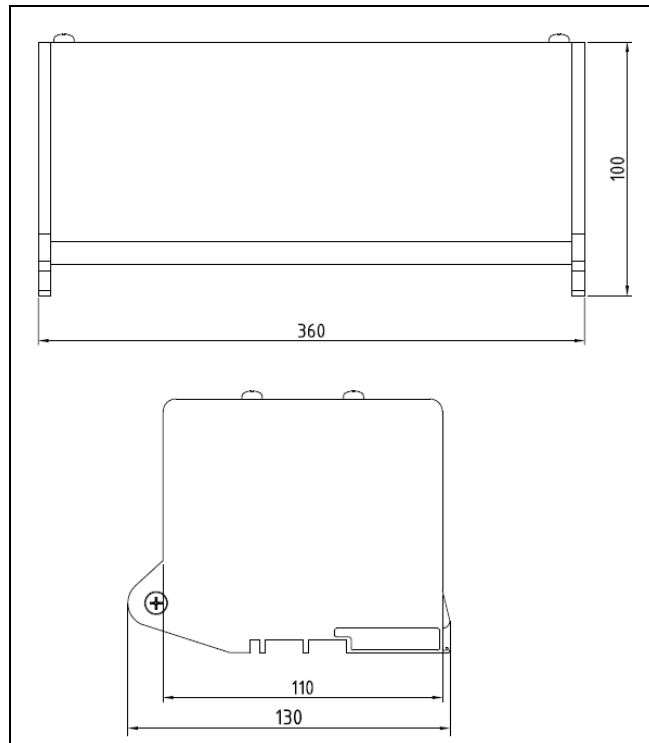

Fig. 5 Dimensions KEH-P03-P08, FORCE-1.DIN.3, FORCE-1.DIN.4

6 Installation



DANGER

Danger of electric shock!

Touching live parts can cause death by electric shock.

- All the electrical connections must be carried out by an electrician who has all the relevant information for the job. Always observe laws, regulations and standards applicable at the site of installation and operation.

- 1 Check the packaging before accepting the control unit.
- 2 Open the packaging and take out the control unit.
- 3 Check the control unit for transport damage!
- 4 Compare the control unit with the specifications given in the order!



DANGER

Danger caused by short-circuit.

Never start up the control unit if you have detected visual damage!

- Notify the freight carrier or SCHUNK GmbH & Co. KG immediately if you detect damage and/or missing components! (With all the relevant details.)

- 5 Compare the performance data on the identification plate of the control unit with the data of the electricity grid on site.

- 6 Position the control unit inside the electrical cabinet of the machine tool, making sure that the requirements of the IP protection class ([5, Page 10](#)) are met. We recommend installing the control unit and its power supply interrupting devices in an easily accessible place for maintenance and repairs, at a distance of **approx. 0.6 to 1.7 m** above the operating level.

	NOTICE
	<p>Damage to the control unit due to a short-circuit. The control unit could be damaged by oil or water.</p> <ul style="list-style-type: none"> • The positioning of the control unit inside the machining area of the machine tool should be avoided during its installation and operation. Please install the control unit always and only on the inside of the machine tool's electrical cabinet.

- 7 Carry out all the electrical connections necessary for the use of the product according to the enclosed wiring diagram.

The following devices must be installed upstream to the control unit in order to protect the unit, other devices and persons:

- 1 Protection device for overcurrent, i.e. fuse or circuit breakers. This device must comply with the specifications indicated on the wiring diagram, of the control unit as well as with the relevant regulations and standards applicable in the country of installation and operation. These devices must be designed for **for aM characteristics in the case of fuses and with tripping characteristic C in the case of circuit breakers.**
- 2 **A highly sensitive residual current circuit breaker of 30 mA, with 32 A rated current and A or B characteristics in case of earth leakage current.** Some applications may require a residual current circuit breaker of a different size. Please refer for this purpose to the corresponding wiring diagram.

Automatic power off must be checked at the end of installation!

NOTE

Always connect the grounding conductor of the feeder cable, in order to avoid electric shocks and reduce interferences. The user is has to guarantee an efficient grounding, complying with the current regulations.

7 Initial commissioning and normal operation



7.1 Initial commissioning

After having installed the control unit ([☞ 6, Page 14](#)) as well as the electro-permanent magnetic chucks connected to the same, the following proper functioning must be checked:



- 1 Ensure that the magnetic chuck is not magnetized, by means of the steel tip of a screw driver.

NOTE

There may be slight remanent magnetization upon delivery, e.g. due to the handling of the chucks with lifting magnets.

	 DANGER
	<p>Danger of electric shock due to a faulty connection. Touching live parts can cause death by electric shock.</p> <ul style="list-style-type: none"> • The following step may only be taken after a correct installation and inspection of the protection devices (☞ 6, Page 14).

- 2 Apply voltage to the control unit.
- 3 Place the workpiece onto the magnetic chuck.



	 WARNING
	<p>Danger due to suspended loads. If this work requires the use of lifting equipment, cranes etc., please keep the respective safe distances!</p>

- 4 Carry out a magnetization test.

REMARK

For a proper connection of the external control signals, please refer to the specific wiring diagram the control unit is supplied with.

- 5 Make sure that the workpiece remains clamped onto the magnetic chuck.



	 CAUTION
	<p>Risk of injury due to workpieces coming undone due to a faulty display of the magnetic system.</p> <ul style="list-style-type: none"> • Ensure that the workpiece is properly clamped on the magnetic chuck (for example with the steel tip of a screwdriver), by taking the suitable safety precautions!

- 6 Carry out a demagnetization cycle.

REMARK

For a proper connection of the external control signals, please refer to the specific wiring diagram the control unit is supplied with.

- 7 Make sure that the workpiece has been released from the magnetic chuck.
- 8 Remove the workpiece from the magnetic chuck.

	 WARNING
	<p>Danger due to suspended loads.</p> <p>If this work requires the use of lifting equipment, cranes etc., please keep the respective safe distances!</p>

- 9 Please contact SCHUNK if the expected results are not achieved even after having strictly followed the a.m. steps.



PLEASE NOTE

Please always have the serial no. at hand when contacting SCHUNK about technical matters!



7.2 Normal operation

To guarantee a proper functioning of the control unit, please carry out the following steps:



- 1 Ensure that the magnetic chuck is not magnetized, by means of the steel tip of a screw driver.
- 2 Apply voltage to the control unit.
- 3 Place the workpiece onto the magnetic chuck.

	 WARNING
	<p>Danger due to suspended loads. If this work requires the use of lifting equipment, cranes etc., please keep the respective safe distances!</p>

- 4 Carry out a magnetization cycle on the chuck.
- 5 Make sure that the workpiece remains clamped onto the magnetic chuck.

	 CAUTION
	<p>Risk of injury due to workpieces coming undone due to a faulty display of the magnetic clamping system.</p> <ul style="list-style-type: none"> • Ensure that the workpiece is properly clamped on the magnetic chuck (for example with the steel tip of a screwdriver), by taking the suitable safety precautions!

- 6 The workpiece is now ready to be machined.
- 7 Carry out the demagnetization of the chuck.
- 8 Make sure that the workpiece has been released from the magnetic chuck.
- 9 Remove the workpiece from the magnetic chuck.

	 WARNING
	<p>Danger due to suspended loads. If this work requires the use of lifting equipment, cranes etc., please keep the respective safe distances!</p>

- 10 Please contact SCHUNK if the expected results are not achieved even after having strictly followed the a.m. steps.



NOTICE

Damage to the magnetic chuck due to overheating

The control unit has been designed with different cycle times (magnetization and demagnetization) depending on the magnetic chuck and / or defined upon order placement to avoid any overheating of the chuck itself ([↩ 5, Page 10](#)). Non-observance of these instructions may cause irreversible damage to the magnetic chucks and render the warranty void!

8 Troubleshooting



Problem	Possible cause	Corrective action
The workpiece shifts on the magnetic chuck because it is not properly clamped	The magnetization cycle has not been performed correctly.	Check the electric connections between the control unit and the magnetic chuck.
	The magnetization power adjusted on the remote control is not sufficient.	If the remote control with adjustable power is used, increase the power and repeat the magnetization cycle.
The residual current device disconnects the circuit	Current leaks out of the intended circuit.	Disconnect the discharge cable of the magnetic chuck and make sure there is no earth leakage
After having turned on the power supply, the control unit remains switched off.	The feeder cable is not correctly connected.	Switch off the electrical cabinet and check the connection to the electricity grid
The demagnetization cycle is not carried out correctly	Interferences affect the regular functioning of the control unit.	Install a mains filter upstream to the control unit.

PLEASE NOTE

Please always have the serial no. at hand when contacting SCHUNK about technical matters!

9 Servicing and maintenance

Excellent and careful maintenance is a decisive factor for optimum safety, functioning and performance and a longer service life of the product.

	 DANGER
	<p>Maintenance work must always be performed by an electrician. The maintenance personnel must read this operating manual carefully. Work inside the control unit must be done by SCHUNK Service personnel only.</p>

This type of control unit has exclusively been designed to be installed inside the electrical cabinet of the machine tool and doesn't therefore require any specific maintenance.

However, we recommend checking the conditions of the connection cables to the mains and to the magnetic chucks on a monthly basis.

Furthermore, the proper operation of the residual current device upstream of the control unit has to be checked regularly, according to the manufacturer's recommended intervals and methods.

Please follow the a.m. instructions and maintenance intervals so as to avoid repairs and resulting down-times, failures and inconvenience.

Defective electrical and electromechanical components must always be replaced by SCHUNK Service personnel. If components are replaced by the operator, this automatically renders the warranty void.

After maintenance and before reconnecting and restarting the control unit, all protection devices must be reinstalled.

10 Storage

When storing the control unit for a longer period of time (max. 8 months), observe the following instructions to ensure its functionality up to the time of installation:

- Ensure correct packaging!
Recommendation: store the product in its original packaging.
- The control unit and the packaging should be inspected at regular intervals.
- Inspect packaging for outer damage and effects due to impacts or weather.
- Make sure that the ambient temperature and humidity inside the warehouse correspond to the specifications indicated in the present user's and maintenance manual.

11 Disposal



This product is made of plastic, electrical, and electronic components. If it is taken out of operation, it has to be disposed of in compliance with the applicable regulations.

As soon as the end of the lifecycle has been reached, the control unit has to be decommissioned, i.e. put into a state in which it can no longer be used for its original intended use and in which it is still possible to recycle the raw materials contained.

NOTE

SCHUNK GmbH & Co. KG assumes no liability for material damage or personal injury that may result from reusing individual components of the control unit for purposes other than the original intended use! SCHUNK GmbH & Co. KG provides neither implicit nor explicit declarations about possible usability of recycled components after decommissioning the control unit.

Procedure for final decommissioning and disposal of the control unit:

	 CAUTION
	<p>Risk of injury. Decommissioning, disassembly and disposal of the control unit must be performed by qualified persons using suitable tools.</p>

- 1 Ensure that the machine tool has safely come to a halt. Disconnect all the electrical, hydraulic and pneumatic connections that could cause unexpected movements of the machine or its components.
- 2 Disconnect the product from all devices.
 - ⇒ Have the control unit disposed of by a company specialized in the disposal of electrical equipment.

12 Spare parts

Please contact the SCHUNK service department for any spare parts request.