

# **Assembly and Operating Manual**

## **EWAG flange mounting**

### **Tool grinding toolholder**

Translation of Original Operating  
Manual

## Imprint

### Copyright:

This manual is protected by copyright. The author is SCHUNK SE & Co. KG.  
All rights reserved.

### Technical changes:

We reserve the right to make alterations for the purpose of technical improvement.

**Document number:** 1521602

**Version:** 03.00 | 08/01/2026 | en

Dear Customer,

Thank you for trusting our products and our family-owned company, the leading technology supplier of robots and production machines.

Our team is always available to answer any questions on this product and other solutions. Ask us questions and challenge us. We will find a solution!

Best regards,

Your SCHUNK team

Customer Management

Tel. +49-7133-103-2500

Fax +49-7133-103-2239

cms@de.schunk.com



**Please read the operating manual in full and keep it close to the product.**

## Table of Contents

<b>1 General</b> .....	<b>5</b>
1.1 About this manual.....	5
1.1.1 Presentation of Warning Labels .....	5
1.1.2 Definition of Terms .....	6
1.1.3 Symbol definition.....	6
1.1.4 Applicable documents .....	6
1.2 Warranty .....	6
1.3 Scope of delivery.....	7
1.4 Accessories .....	7
<b>2 Basic safety notes</b> .....	<b>8</b>
2.1 Intended use.....	8
2.2 Not intended use .....	8
2.3 Notes on safe operation.....	9
2.4 Personnel qualifications .....	10
2.5 Personal protective equipment .....	11
2.6 Handling during transport .....	11
2.7 Structural changes.....	12
2.8 Behavior in case of malfunctions.....	12
2.9 Hazardous points on the product.....	13
<b>3 Technical data</b> .....	<b>14</b>
3.1 Product data .....	14
3.2 Ambient conditions and operating conditions .....	15
3.3 Installation details .....	15
3.4 Additional information for screw connections .....	15
<b>4 Design and description</b> .....	<b>16</b>
4.1 Design .....	16
4.2 Description of function .....	17
4.3 Integrated additional functions.....	17
4.3.1 Adjustment screw.....	17
<b>5 Assembly</b> .....	<b>18</b>
5.1 Basic information.....	18
5.2 Assembly of the product .....	19
<b>6 Settings and functional testing</b> .....	<b>20</b>
6.1 Basic information.....	20
6.2 Adjusting the actuating force.....	22
6.3 Checking the clamping function via contact force or manual actuation .....	24

<b>7 Operation</b> .....	<b>26</b>
7.1 Basic information.....	26
7.2 Clamping of the workpiece via contact force or manual actuation.....	28
7.2.1 Clamping via manual actuation.....	28
7.2.2 Clamping via contact pressure.....	29
7.3 Unclamping the workpiece.....	29
7.4 Using the intermediate sleeve.....	30
7.4.1 Assembly/disassembly of the intermediate sleeve.....	31
7.5 Using the adjustment screw.....	34
7.5.1 Readjustment for manual operation.....	34
7.5.2 Readjusting with pressure force actuation.....	35
<b>8 Maintenance</b> .....	<b>36</b>
8.1 Basic information.....	36
8.2 Intervals and tasks.....	37
8.2.1 Clean the clamping surface and workpiece stop face.....	38
8.2.2 Cleaning the product.....	38
8.2.3 Check the expansion rate.....	40
8.2.4 Lubricate the clamping screw and actuating thread.....	43
8.2.5 Polish the clamping surface.....	44
8.2.6 Disassembly/changing of the intermediate sleeve.....	48
<b>9 Troubleshooting</b> .....	<b>50</b>
<b>10 Disassembly</b> .....	<b>51</b>
10.1 Basic information.....	51
10.2 Disassembly of the product.....	51
<b>11 Storage</b> .....	<b>52</b>
<b>12 Disposal</b> .....	<b>53</b>
<b>13 Drawings</b> .....	<b>54</b>
<b>14 Declaration of incorporation</b> .....	<b>55</b>

# 1 General

## 1.1 About this manual

This manual contains important information for a safe and appropriate use of the product.

This manual is an integral part of the product and must be kept accessible for the personnel at all times.

Before starting work, the personnel must have read and understood this operating manual. Prerequisite for safe working is the observance of all safety instructions in this manual.

In addition to these instructions, the documents listed under ▶ 1.1.4 [ 6 ] are applicable.

**NOTE:** The illustrations in this manual are intended to provide a basic understanding and may deviate from the actual version.

### 1.1.1 Presentation of Warning Labels

To make risks clear, the following signal words and symbols are used for safety notes.



#### **⚠ DANGER**

**Dangers for persons!**

Non-observance will inevitably cause irreversible injury or death.



#### **⚠ WARNING**

**Dangers for persons!**

Non-observance can lead to irreversible injury and even death.



#### **⚠ CAUTION**

**Dangers for persons!**

Non-observance can cause minor injuries.

#### **NOTICE**

**Material damage!**

Information about avoiding material damage.

### 1.1.2 Definition of Terms

The term "product" replaces the product name on the title page in this manual.

### 1.1.3 Symbol definition

The following symbols are used in this manual:

■ Prerequisite for an action

1. Action 1

2. Action 2

⇒ Intermediate results

⇒ Final results

▶ 1.1.3 [6]: chapter number and [page number] in hyperlinks

### 1.1.4 Applicable documents

- General terms of business \*
- Contractual agreements

The documents labeled with an asterisk (\*) can be downloaded from [schunk.com/downloads](https://www.schunk.com/downloads).

## 1.2 Warranty

If the product is used as intended, the warranty is valid for 12 months from the date of delivery from the production facility or 50 000 cycles\* under the following conditions:

- Observe the applicable documents, ▶ 1.1.4 [6]
- Observe the ambient conditions and operating conditions, ▶ 3.2 [15]
- Observe the specified maintenance instructions, ▶ 8 [36]

This does not include special agreements detailed in the warranty and wearing parts. Wearing parts can also become worn through appropriate use before the maximum number of clamping cycles has expired. This includes all areas which come into contact with the workpiece or the machine (clamping area and mount) and sealing elements.

\* One cycle comprises one complete clamping procedure ("clamping" and "unclamping").

### 1.3 Scope of delivery

The scope of delivery includes

- 1 **Hydraulic expansion toolholder** in the ordered variant (0206766; 0206767; 0206768; 0206769)
- 1 **Assembly and Operating Manual** (ID 1521602)
- 1 **Accessory kit, intermediate sleeve lock** (20041397)
- 1 **Hexagon socket wrench for adjustment screw SW5x100** (9205650)

### 1.4 Accessories

The following accessories for the product are available separately:

**Intermediate sleeve without lock GZB-S PK**  
not coolant-proof

**Intermediate sleeve without lock GZB-S KD**  
coolant-proof

**Intermediate sleeve with lock GZB-S KD/RS**  
coolant-proof

**Sleeve remover** (ID 9937987)

## 2 Basic safety notes

### 2.1 Intended use

- The product is intended for picking up, clamping and reliably holding fully cylindrical workpieces (the tools to be ground are workpieces in this case).
- The product is used for tool grinding.
- The product is intended for industrial use.
- The product may only be used and applied within the scope of the information in the technical data, ▶ 3 [14].
- The product is intended for installation in a machine/ automated system. The applicable guidelines for the machine/ automated system must be observed and complied with.
- Appropriate use of the product includes compliance with all instructions in this manual.

### 2.2 Not intended use

The product is not being used as intended if, for example:

- Tools or similar are picked up and clamped in order to machine workpieces.
- The product is used for something other than tool grinding.
- The information in the technical data is not observed when using and operating the product ▶ 3 [14].
- The product is used as a lifting tool.
- The minimum clamping depth is not observed (clamping length is not completely covered).
- The expansion rate control system is not observed ▶ 8.2.3 [40].
- The product is used in corrosive media.
- The maintenance and storage instructions are not observed ▶ 8 [36].

## 2.3 Notes on safe operation

Disregarding the instructions for safe operation can make the product unsafe and risks serious injuries and considerable material damage.

- Observe and comply with all safety instructions and warnings as well as the specifications in the assembly and operating manual.
- Use the product as intended ▶ 2.1 [8].
- All work may only be performed by appropriately qualified personnel ▶ 2.4 [10].
- Rectify malfunctions as soon as they occur ▶ 2.8 [12].
- Never deactivate safety installations.
- Observe safety distances.
- Before commissioning the product, take suitable protective measures to secure the danger zone.
- Secure the system against accidental operation during all work.
- Disconnect power sources before installation, modification, maintenance, or calibration. Ensure that no residual energy remains in the system.
- If the energy supply is connected, do not move any parts by hand.
- Never step into the danger zone during operation.
- Do not reach into the movement area of the product or into the open mechanism during operation.
- Avoid any manner of working that may interfere with the function and operational safety of the product.
- Comply with the current safety, accident prevention, and environmental protection regulations for the application field of the product.

If you have any questions regarding safe operation, our technical after-sales service is available during our business hours:

**Service telephone: +49-7133-103-2956**

**service.toolholder@de.schunk.com**

## 2.4 Personnel qualifications

Work conducted on and with the product by inadequately qualified personnel can lead to serious injuries and considerable material damage.

- Personnel must have read and understood the complete manual before beginning any work on the product.
- All work may only be performed by appropriately qualified personnel:
  - **Specialist personnel**  
Specialist personnel have the specialized training, knowledge, and experience to perform the tasks entrusted to them, to recognize and avoid potential dangers, and know the relevant standards and regulations.
  - **Instructed person**  
An instructed person has been instructed by the operator regarding the tasks entrusted to them and the potential dangers of inappropriate handling of the product.

Work on the product	Necessary qualification
Transport	Qualified personnel/ instructed person
Assembly/disassembly	Specialist personnel
Settings/functional testing	Specialist personnel
Operation	Qualified personnel/ instructed person
Maintenance/troubleshooting	Specialist personnel/ SCHUNK service personnel
Disposal	Specialist personnel/ SCHUNK service personnel

## 2.5 Personal protective equipment

Personal protective equipment is necessary to protect staff in the event of a danger that may interfere with their health or safety at work.

- Observe the valid safety and accident prevention regulations and health & safety at work rules.
- When working on and with the product, wear the required personal protective equipment.
  - Always wear safety boots.
  - Wear close-fitting protective clothing and place a hairnet over long hair when dealing with moving components.
  - Wear protective gloves to guard against sharp edges and corners and rough surfaces.
  - Wear heat-resistant protective gloves when handling hot surfaces.
  - Wear protective gloves and safety goggles when handling hazardous substances.

## 2.6 Handling during transport

Incorrect handling during transport can make the product unsafe and risks the danger of serious injuries and considerable material damage.

- During transport and handling, secure the product to prevent it from falling.
- Do not walk under suspended loads.
- Do not leave suspended loads unattended.
- Observe the assembly and operating manual specifications for transport.
- Use suitable assembly and transport devices\*.
- Take precautions against pinching and crushing.

\* Assembly and transportation devices must be able to carry at least twice the attached weight.

## 2.7 Structural changes

Modifications, changes or reworking, e.g. additional threads or holes, can damage the product or impair its functionality or safety.

- Structural changes should only be made with the written approval of SCHUNK.
- Use only original spare parts and spares authorized by SCHUNK.

## 2.8 Behavior in case of malfunctions

Incorrect handling during a malfunction can make the product unsafe and risks the danger of serious injuries and considerable material damage.

- Immediately remove the product from operation and report the malfunction to the responsible departments/persons.
- Get appropriately qualified personnel ▶ 2.4 [10] to rectify the malfunction.
- Observe the information on troubleshooting in the assembly and operating manual.
- Faults not described in the assembly and operating manual may only be rectified after consultation with SCHUNK.
- After a malfunction, ensure that the product is able to function properly and no increased risks have arisen.
- Do not recommission the product until the malfunction has been rectified.

## 2.9 Hazardous points on the product

Hazardous points on the product pose a particular risk. Failure to observe the warnings in the relevant chapters of this manual can result in serious injury and considerable damage to property.

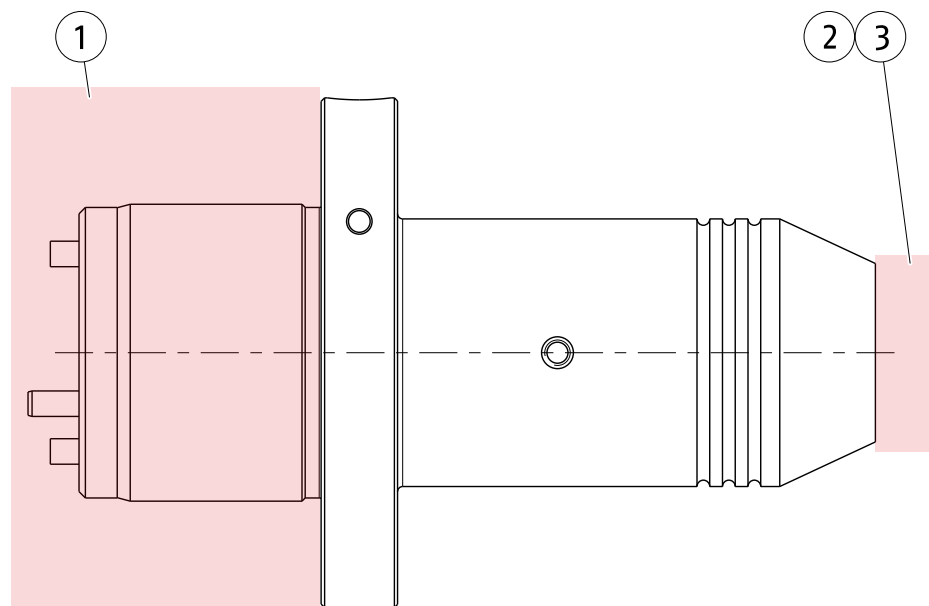

**NOTE:** Illustration may differ from the actual design.

Position	Danger when	Danger due to
1	Assembling/disassembling the product	Crushing risk
2	Operating/clamping the product	The expansion sleeve bursting
3	Workpiece change	Crushing risk

### 3 Technical data

#### 3.1 Product data

<b>ID</b>	<b>0206766; 0206767; 0206768; 0206769</b>			
Operation	Grinding			
Insertion position	Horizontal			
Clamping actuation	Pressure actuated to stop / manually actuated			
Maximum permissible speed of rotation [RPM]	3000			
Maximum permissible speed of rotation without workpiece [RPM]	10			
Product mount	Flange mounting			
<b>ID</b>	<b>0206766</b>	<b>0206767</b>	<b>0206768</b>	<b>0206769</b>
Minimum clamping depth [mm]	37.6	37	41	48.5
Piston stroke, theoretical [mm]	6.5	6	6	8
Actuating force, theoretical [kN]	4.2	4.2	4.0	4.0
Clamping force, theoretical [kN]	6	27	33	54
Maximum transmittable torque, theoretical [Nm]	6	43	58	140
Expansion rate [mm]	0.034	0.052	0.057	0.080
Clamping diameter, product [mm]	12 +0.005/+0.002	20 +0.006/+0.003	22 +0.006/+0.003	32 +0.006/+0.003
Clamping length [mm]	32.1	31.5	35.5	42.5
Workpiece diameter [mm]	12 h7 (0/-0.018)	20 h7 (0/-0.021)	22 h7 (0/-0.021)	32 h7 (0/-0.025)
Set-screw, intermediate sleeve lock	M4	M4	M4	M4
Weight [kg]	approx. 1.3	approx. 1.1	approx. 1.4	approx. 1.6

### 3.2 Ambient conditions and operating conditions

Specification	Value
Operating temperature range	+18°C to +25°C
Maximum product temperature	+35°C
Test temperature range for the expansion rate check	+23°C ±2°C
Storage temperature range	+20°C ±10°C
Relative air humidity	20 to 80%

**NOTE:** The temperatures refer to the product.

### 3.3 Installation details

Number of mounting screws, product	4
Screw size	M5 (min. 14 mm long) ISO 4762 12.9 (not included in scope of delivery)

### 3.4 Additional information for screw connections

Observe the manufacturer specifications of the machine spindle regarding the tightening torque for mounting screws and the required screw-in depth. If there are no specifications for the screw-in depth, this must be determined using the relevant applicable guidelines.

If no tightening torques are specified, the values in the table below should be used as guide values.

**CAUTION! Only use screws with strength class 12.9 for fastening!**

Screw size	M4	M5	M6	M8	M10	M12	M14	M16	M18	M20
Tightening torque [Nm]	5.3	11	18	43	85	150	230	360	490	700

**Incorrect screw tightening torques can damage the machine spindle and product.**

If you have any questions regarding the tightening torque, our technical after-sales service is available during our business hours:

**Service telephone: +49-7133-103-2956**  
**service.toolholder@de.schunk.com**

## 4 Design and description

### 4.1 Design

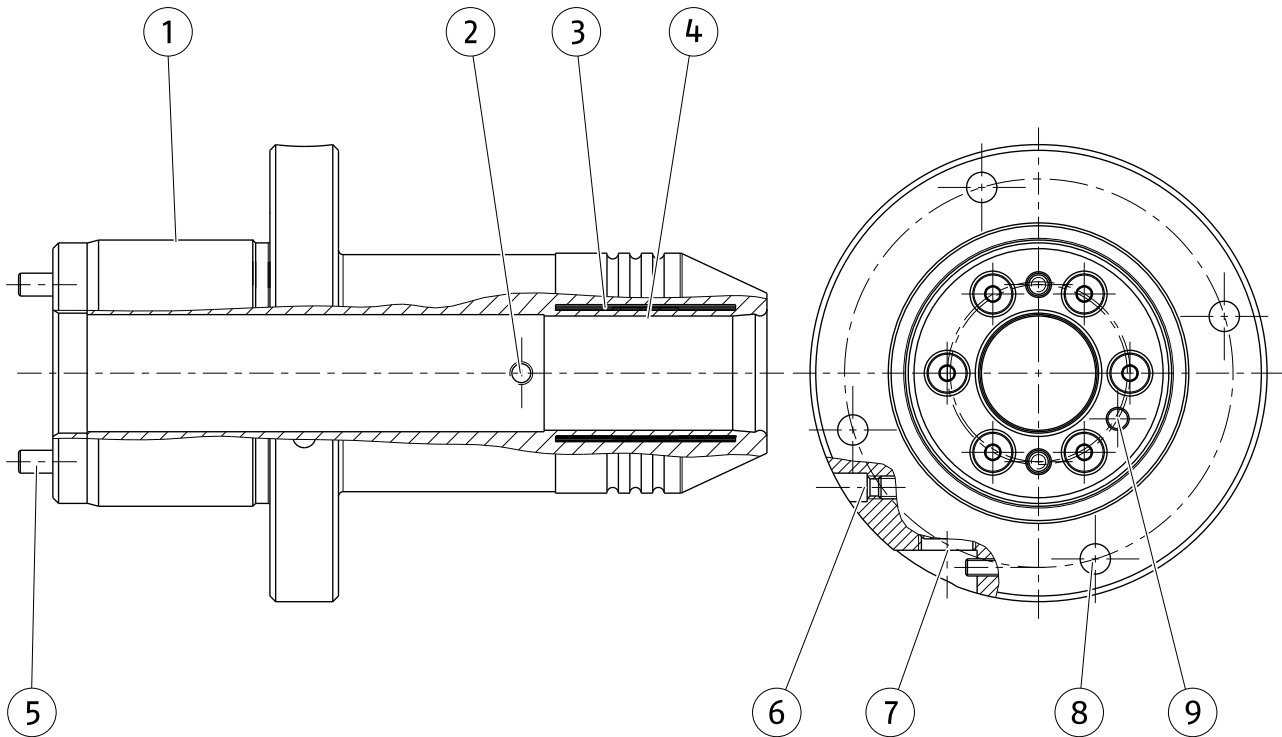

**NOTE:** Illustration may differ from the actual design.

Position	Description
1	Product mount
2	Locking screw thread, intermediate sleeve
3	Active clamping length
4	Clamping surface
5	Clamping piston
6	Clamping screw
7	Adjustment screw
8	Product mounting holes
9	Locating pin

## 4.2 Description of function

This product has two clamping options. The manual actuation against stop via a clamping screw or the pressure actuation against stop via the machine piston. To achieve the required clamping force, both clamping options must always be activated.

To operate the product by hand, the clamping screw must be screwed in as far as it will go. For clamping by pressure force, the clamping piston of the product is retracted to the stop. To do so, the clamping piston must be acted on by pressure force via the machine piston.

The volume of oil that is squeezed out of the piston chamber is pressed in measured amounts against the thin-walled expansion sleeve. The resulting internal pressure radially presses against the thin-walled expansion sleeve, causing the clamping range to expand evenly along the entire active clamping length, centrally equal to the middle axis. The workpiece is clamped.

Removing the actuating force or screwing back the clamping screw causes a reduction of the pressure in the piston chamber and the expansion chamber. The thin-walled expansion sleeve then returns radially to its exact home position. The workpiece can be removed.

## 4.3 Integrated additional functions

### 4.3.1 Adjustment screw

The adjustment screw is used to compensate the expansion rate and therefore also the clamping force. The lower the expansion rate, the lower the clamping force. The adjustment screw can be used to respond to oil loss, e.g. due to leakage, and to ensure safe clamping.

## 5 Assembly

### 5.1 Basic information



#### **⚠ WARNING**

##### **Risk of injury due to incorrect assembly.**

If assembled incorrectly, the product and/or its attachments may be thrown out during rotation, causing severe injuries.

- Comply with technical data.
- Observe the tightening torques for screws.
- Only use screws with strength class 12.9 and the appropriate length.
- Regularly check the mounting of the product and all of its attachments.
- Take suitable protective measures to secure the danger zone.
- Wear suitable protective equipment.



#### **⚠ WARNING**

##### **Risk of injury if the product falls during transport, assembly or disassembly!**

Due to the oily surface required to preserve it, the product can slip through your hands, resulting in injury.

- Take appropriate safety measures to prevent the product from falling.
- Only install the product on machines with the appropriate connection dimensions.
- Wear suitable protective equipment, especially safety gloves.



#### **⚠ CAUTION**

##### **Risk of crushing and impact when assembling and disassembling the product!**

- Do not reach between the product and machine.
- Wear suitable protective equipment.

**NOTICE****Possible damage to the expansion sleeve!**

- When transporting and handling the product, ensure that it is not damaged by knocks, impacts, etc.
- It is essential that the thin-walled clamping face (expansion sleeve) is protected against shocks and impacts.

**5.2 Assembly of the product**

To ensure optimal machining results, the product must be precisely positioned and secured on the machine interface.

**NOTE:** Only mount the product and attachments on machines with suitable connection dimensions. Observe the mounting instructions from the machine interface manufacturer.

**NOTE:** Mounting screws are not included in the scope of delivery.

1. Observe the technical data ▶ 3 [14] and the marking on the product.
2. Clean all interfaces on the product and machine.
3. Place the product on the machine interface in the correct position and fit it as far as the stop.
4. Mount the product onto the machine interface using appropriate mounting screws ▶ 3.3 [15]. Tighten the mounting screws only slightly.
5. Clamp a suitable test workpiece to adjust the run-out.
6. Apply a suitable measuring device to the test workpiece. During alignment, check the concentricity at the test specimen with a suitable measuring device at a maximum speed of 10 RPM.
7. Adjust the run-out by tightening the mounting screws in a criss-cross pattern until the specified tightening torque ▶ 3.4 [15] is reached.

**NOTICE! Safe and correct mounting of the product on the machine interface must be ensured!**

## 6 Settings and functional testing

### 6.1 Basic information



#### **⚠ WARNING**

**Risk of injury and material damage due to the expansion sleeve cracking.**

If the expansion sleeve cracks, oil may be emitted at high pressure and chips or broken pieces may fly off, causing severe injuries.

- Avoid knocking or banging the expansion sleeve.
- The specified expansion rate may not be exceeded.
- Observe the inspection temperature specified in the technical data to check the expansion rate.
- Secure the danger zone by taking suitable protective measures.
- Wear suitable protective equipment.

To ensure correct operation and to test the product functions, various settings and functional checks must be carried out before initial operation. These may vary depending on the version and are described in the following sub-chapters.

This product has two clamping options. Manual actuation against stop or pressure actuation against stop.

Before commissioning, the clamping force of the product is checked via the functional test. Once via manual actuation and once via pressure actuation. In addition to the clamping force, the actuating force of the machine is checked with the pressure actuation. First clamp the product without and then with the workpiece.

**NOTE:** The product may only be operated without a workpiece for the settings and functional tests!

If you have any questions regarding settings and functional tests, our technical after-sales service is available during our business hours:

**Service telephone: +49-7133-103-2956**  
**service.toolholder@de.schunk.com**



## 6.2 Adjusting the actuating force

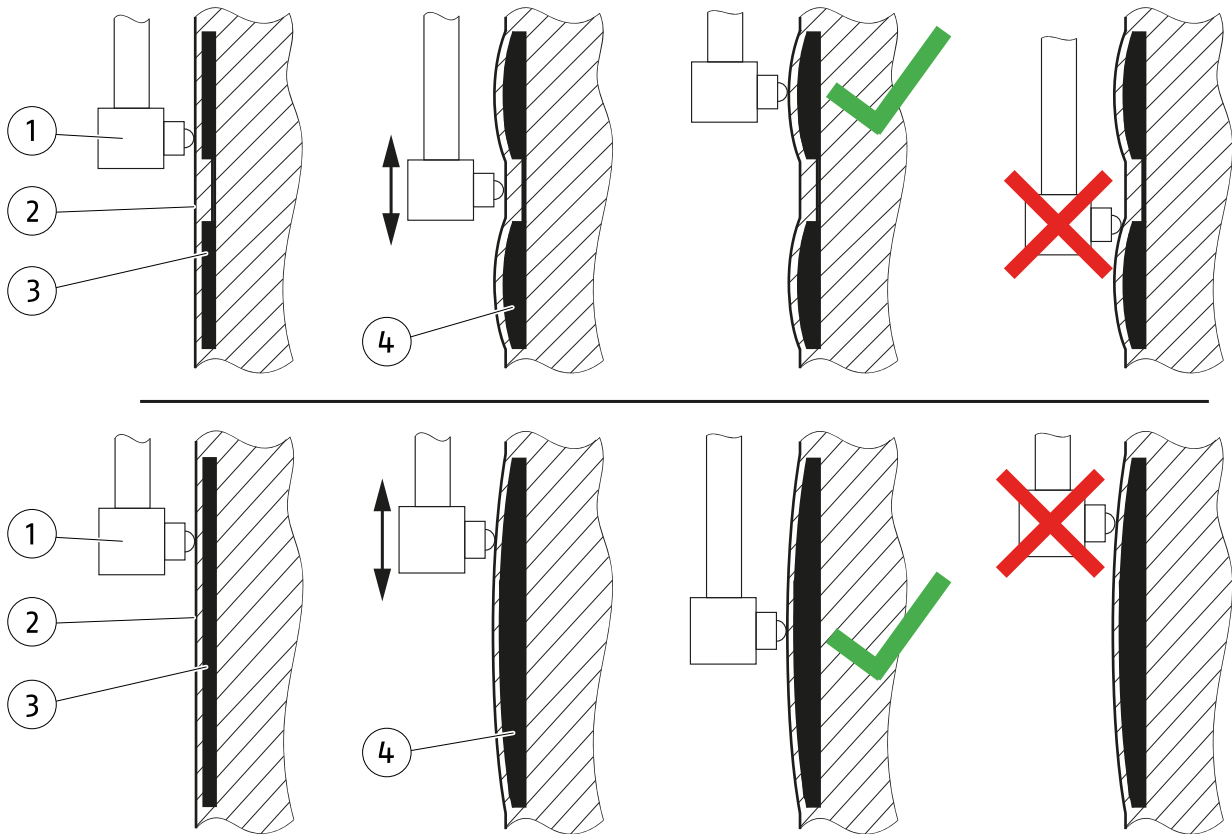

**NOTE:** Illustration is for reference only. Shape of the expansion chamber may differ.

Position	Description
1	Measuring device
2	Clamping surface
3	Expansion chamber (unclamped)
4	Expansion chamber (clamped)

Before initial operation, check the expansion rate to adjust the actuating force.

To do this, use a measuring device that meets the following requirements:

- Either two-point inside caliper or dial gauge outside micrometer  
**NOTE:** The measuring device must be spring-loaded!
- Measuring resolution of 0.001 mm
- Analog dial gauge
- Sufficiently large range of measurement (greater than expansion rate)

**CAUTION! Observe the test temperature for the expansion rate check ▶ 3.2 [ 15]!**

1. Observe the technical data ▶ 3 [ 14] and the marking on the product.
2. Make sure that the product is mounted correctly.
3. Make sure that the product is in an unclamped state.
4. Clean the clamping surface.
5. Place the measuring device at the center of the clamping surface and set it to zero. **NOTE:** Make sure that the dirt groove (if present) on the clamping surface does not influence the measuring device!
6. Carefully apply a constantly increasing actuating force to the product via the machine from 0 until a change in the clamping diameter is visible on the measuring device.
  - ⇒ Product is pre-loaded, the expansion chamber has deformed the clamping surface.
7. Move the measuring device on the clamping surface until the point with the highest deflection is determined.
8. Position the measuring device at the point with the highest deflection.
9. **CAUTION! As soon as the expansion rate is reached, do not increase the actuating force any further!** Carefully apply constantly increasing actuating force to the product until the difference on the measuring device matches the expansion rate ▶ 3 [ 14] specified in the technical data.
10. Note the actuating force applied when the expansion rate is reached.
11. Return the actuating force of the machine to 0.
12. **CAUTION! The duration of actuation must be longer than 2 seconds!** Apply previously determined actuating force to the product and measure the time until the expansion rate ▶ 3 [ 14] specified in the technical data is reached.
13. Return the actuating force of the machine to 0.

---

**NOTE**

If the expansion rate given in the technical data is not reached, our technical after-sales service is available during our business hours:

**Service telephone: +49-7133-103-2956**  
**service.toolholder@de.schunk.com**

---

## 6.3 Checking the clamping function via contact force or manual actuation

### Checking the clamping function via manual actuation

**NOTE:**The product is only allowed to be clamped with manual actuation **or** contact force.

1. Observe the technical data ▶ 3 [ 14] and the marking on the product.
2. Make sure that the product is mounted correctly.
3. Make sure that the product is in an unclamped state.
4. Screw in the clamping screw as far as the stop.
5. Check the clamped clamping diameter and compare with the value specified in the technical data ▶ 8.2.3 [ 40].
6. To unclamp the product, loosen the clamping screw again.
7. Place the test workpiece on the product in the correct position and up to the stop without exerting too much force.  
**IMPORTANT! Observe the minimum clamping depth ▶ 3 [ 14]!**
8. Screw in the clamping screw as far as the stop.
9. Check that the test workpiece is firmly in place.

### Checking the clamping function via contact force

**NOTE:** The product is only allowed to be clamped with manual actuation or contact force.

1. Observe the technical data ▶ 3 [14] and the marking on the product.
2. Make sure that the product is mounted correctly.
3. Make sure that the product is in an unclamped state.
4. Pressurize the product from 0 onward without a workpiece with a constantly increasing actuating force via the machine piston until the clamping piston has retracted to the stop or the clamping diameter specified in the technical data has been reached.
5. Check the clamped clamping diameter and compare with the value specified in the technical data ▶ 8.2.3 [40].
6. Note the actuating force applied when the clamping diameter is reached.
7. To unclamp the product, return the actuating force of the machine piston to 0.
8. Place the test workpiece on the product in the correct position and up to the stop without exerting too much force.  
**IMPORTANT! Observe the minimum clamping depth ▶ 3 [14]!**
9. Apply the previously determined actuating force to the product.
10. Check that the test workpiece is firmly in place.

**NOTICE!** In order to achieve the maximum clamping force, at least the actuating force stated on the product label or specified in the technical data must be reached and safely maintained.

**NOTICE!** The actuating duration must be longer than 2 seconds.

## 7 Operation

### 7.1 Basic information



#### **⚠ WARNING**

**Risk of injury when the product is rotating, due to the possibility of parts flying off!**

- Comply with the technical data.
- Make sure the attachments and operating components present are installed and fitted correctly.
- Check the clamping force regularly.
- Take appropriate protective measures to secure danger zones.
- Wear suitable protective equipment.



#### **⚠ WARNING**

**Risk of injury due to the workpiece being flung out if the speed of rotation is too high or not suitable!**

- Comply with the technical data.
- Do not exceed the maximum speed.
- Reduce the speed of rotation appropriately in case of far protruding workpieces or workpieces balanced asymmetrically.
- Take appropriate protective measures to secure danger zones.
- Wear suitable protective equipment.



#### **⚠ WARNING**

**Risk of injury and material damage due to the expansion sleeve cracking.**

If the expansion sleeve cracks, oil may be emitted at high pressure and chips or broken pieces may fly off, causing severe injuries.

- Avoid knocking or banging the expansion sleeve.
- Always cover the entire clamping length of the product.
- The specified expansion rate may not be exceeded.
- When the product is tensioned, do not exceed the maximum permissible operating temperature.
- Only operate the product within the optimum operating temperature range.
- Secure the danger zone by taking suitable protective measures.
- Wear suitable protective equipment.



### ⚠ WARNING

**Risk of injury due to the workpiece being flung out if the actuation force is too low or not applied!**

- Comply with the technical data.
- Regularly check actuating force and machine piston.
- Take appropriate measures to secure the danger zones.
- Wear suitable protective equipment.



### ⚠ CAUTION

**Risk of crushing, knocks, and cutting when changing workpieces!**

- When changing the workpiece, do not reach in between the product and the workpiece.
- Prevent unintentional actuation of the product.
- Wear suitable protective equipment, especially protective gloves.

### NOTICE

**Possibility of increased wear, reduced service life, and reduced accuracy of the expansion sleeve.**

If the surface to be clamped on the workpiece is interrupted, the thin-walled expansion sleeve will over-expand at these points (lack of back pressure!).

- Interruptions should be avoided along the surface of the workpiece to be clamped.
- Cover the complete active clamping length of the product.

## 7.2 Clamping of the workpiece via contact force or manual actuation

This product has two clamping options. Manual actuation against stop via a hexagon socket wrench or the contact force actuation against stop via the machine piston.

**WARNING! Only one of the two clamping options is allowed to be used for clamping!**

The product must be unclamped when loading the workpiece. Initial tension inhibits loading and can damage the expansion sleeve.

**CAUTION! The workpiece to be clamped must be deburred at the surfaces that come into contact with the product, may not have sharp contours and must be free of oil, grease and dirt.**

When fitting and clamping the workpiece, take the following points into account:

- It is important to ensure that the product is first securely clamped on the machine interface before the workpiece is loaded and clamped.
- During operation, the product heats up, causing the oil to expand. The clamping piston therefore needs to be able to move back 2–3 mm beyond the initial position when unclamping.

### 7.2.1 Clamping via manual actuation

For clamping, proceed as follows:

1. Make sure that the product is in an unclamped state.
2. Clean any dust and dirt from all product surfaces that come into contact with the workpiece.
3. If necessary, mount a suitable intermediate sleeve ▶ 7.4 [ 30].
4. Place the workpiece on the product in the correct position and up to the stop without exerting too much force.  
**IMPORTANT! Observe the minimum clamping depth ▶ 3 [ 14]!**
5. Screw in the clamping screw as far as the stop.
6. Check that the workpiece is firmly in place.

### 7.2.2 Clamping via contact pressure

For clamping, proceed as follows:

1. Observe the technical data ▶ 3 [ 14] and the marking on the product.
2. Make sure that the product is mounted correctly.
3. Make sure that the product is in an unclamped state.
4. Make sure that the clamping screw is not screwed in. **NOTE:** The clamping screw is not secured against falling out!
5. Clean any dust and dirt from all product surfaces that come into contact with the workpiece.
6. If necessary, mount a suitable intermediate sleeve ▶ 7.4 [ 30].
7. Place the workpiece on the product in the correct position and up to the stop without exerting too much force.  
**IMPORTANT! Observe the minimum clamping depth ▶ 3 [ 14]!**
8. **CAUTION! The duration of actuation must be longer than 2 seconds!** Clamp the workpiece with the previously set actuating force.
9. Check that the workpiece is firmly in place.

**NOTICE! To guarantee reliable clamping during operation, the actuating force must not be more or less than the calculated value.**

### 7.3 Unclamping the workpiece

1. Depending on the type of actuation, to unclamp the product, return the actuating force of the machine piston to 0 or loosen the clamping screw. **NOTE:** The clamping screw is not secured against falling out!
2. Remove workpiece.

## 7.4 Using the intermediate sleeve



### **⚠ WARNING**

#### **Risk of injury due to the intermediate sleeve being hurled out or breaking**

The intermediate sleeve may break or be ejected when the product is operated without a workpiece.

- Only operate the product with a clamped workpiece.
- Take suitable protective measures to secure the danger zone.

### **NOTICE**

#### **Impairment of the clamping function and damage to the product!**

The use of incorrect or unsuitable intermediate sleeves may impair the clamping function of the product or damage the product.

- Comply with the technical data.
- Only use suitable and approved intermediate sleeves.

Depending on the design of the product, an intermediate sleeve is required to reduce the clamping diameter. It is possible to use different types of intermediate sleeves with this product. We generally recommend the use of intermediate sleeves from SCHUNK.

**NOTICE! Only mount or change the intermediate sleeve when the product is unclamped!**

**NOTICE! When using an intermediate sleeve, never operate the product without a clamped workpiece!**

### 7.4.1 Assembly/disassembly of the intermediate sleeve

The following intermediate sleeves can be used to reduce the clamping diameter:

- Intermediate sleeve without lock  
Suitable for manual intermediate sleeve change and manual tool change
- Intermediate sleeve with lock via set-screw  
Suitable for manual intermediate sleeve change and automatic tool change

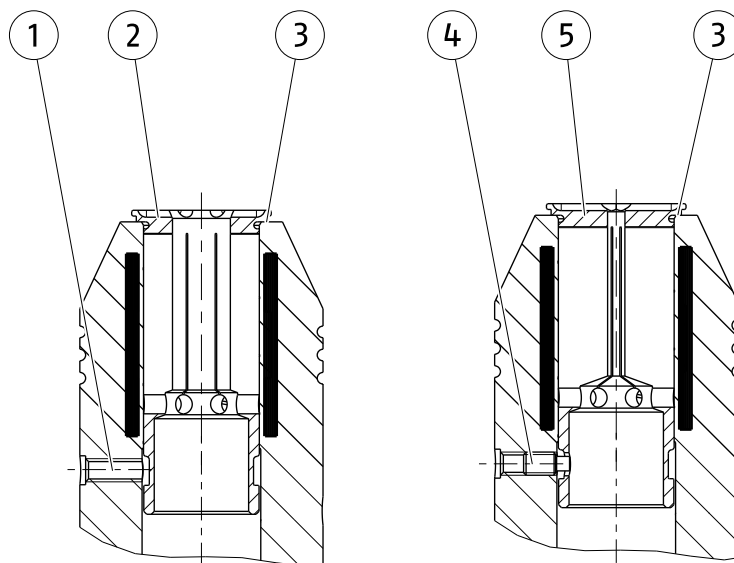

**NOTE:** Illustration may differ from the actual design.

Position	Description
1	Threaded hole for intermediate sleeve with lock
2	Intermediate sleeve without lock
3	Stop face, intermediate sleeve
4	Set-screw with pin
5	Intermediate sleeve with lock

### 7.4.1.1 Intermediate sleeve without lock

#### Assembly

1. Return the actuating force of the machine to 0.
2. Make sure that the product is in an unclamped state.
3. Place the intermediate sleeve on the product in the correct position and fit it as far as the stop without exerting too much force.

#### Disassembly

1. Remove workpiece ▶ 7.3 [📄 29].
2. Make sure that the product is in an unclamped state.
3. Carefully and evenly pull out the intermediate sleeve, keeping it parallel. For this purpose, we recommend the use of a sleeve remover.

**NOTICE! Danger of cutting injuries when changing the intermediate sleeve with workpiece! We always recommend using the workpiece and intermediate sleeve separately.**

### 7.4.1.2 Intermediate sleeve with lock via set-screw

#### Assembly

1. Return the actuating force of the machine to 0.
2. Make sure that the product is in an unclamped state.
3. Place the intermediate sleeve onto the product in the correct position and fit it as far as the stop without exerting too much force, ensuring it remains parallel.

**IMPORTANT! Make sure that the bore hole of the intermediate sleeve matches the position of the bore hole of the set-screw. Otherwise the intermediate sleeve cannot be secured.**

4. Screw in the set-screw only so far that the intermediate sleeve cannot be removed, but still has some clearance.

**IMPORTANT! If the set-screw is screwed in too far, the workpiece loading will be obstructed and run-out errors may occur!**

#### Disassembly

1. Remove workpiece ▶ 7.3 [📄 29].
2. Make sure that the product is in an unclamped state.
3. Unscrew the set-screw.
4. Carefully and evenly pull out the intermediate sleeve, keeping it parallel. For this purpose, we recommend the use of a sleeve remover.

**NOTICE! If no other intermediate sleeve is fitted after disassembly, unscrew the set-screw completely.**

## 7.5 Using the adjustment screw

### NOTICE

#### Possible damage to the expansion sleeve!

An expansion rate that is set too high can damage the expansion sleeve.

- Do not exceed the maximum permissible expansion rate in the technical data.

The adjustment screw is used to compensate the expansion rate and therefore the clamping force. The adjustment screw can be used to respond to oil loss from the product.

### 7.5.1 Readjustment for manual operation

1. Remove the intermediate sleeve ▶ 7.4 [ 30].
2. Screw the clamping screw in until it reaches the stop.
3. Check expansion rate.
4. If present: Loosen the clamping screw of the adjustment screw.
5. Carefully screw in the adjustment screw. **CAUTION: Do not exceed the maximum expansion rate in the technical data!** ▶ 3 [ 14].
  - ⇒ Expansion rate increases.
6. Check the expansion rate for the desired increase.
7. If present: screw in the clamping screw of the adjustment screw.
8. Mount the correct intermediate sleeve ▶ 7.4 [ 30].
9. Check the clamping function ▶ 6.3 [ 24].

**NOTE:** The original expansion rate or clamping force can be restored by unscrewing the adjustment screw.

### 7.5.2 Readjusting with pressure force actuation

1. Remove the intermediate sleeve ▶ 7.4 [14 30].
2. Apply the set actuating force to the product.
3. Check expansion rate.
4. If present: Loosen the clamping screw of the adjustment screw.
5. Carefully screw in the adjustment screw. **CAUTION: Do not exceed the maximum expansion rate in the technical data!** ▶ 3 [14 14].
  - ⇒ Expansion rate increases.
6. Check the expansion rate for the desired increase.
7. If present: screw in the clamping screw of the adjustment screw.
8. Mount the correct intermediate sleeve ▶ 7.4 [14 30].
9. Check the clamping function ▶ 6.3 [14 24].

**NOTE:** The original expansion rate or clamping force can be restored by unscrewing the adjustment screw.

## 8 Maintenance

### 8.1 Basic information



#### **⚠ WARNING**

**Risk of injury and material damage due to the expansion sleeve cracking.**

If the expansion sleeve cracks, oil may be emitted at high pressure and chips or broken pieces may fly off, causing severe injuries.

- Avoid knocking or banging the expansion sleeve.
- The specified expansion rate may not be exceeded.
- Observe the inspection temperature specified in the technical data to check the expansion rate.
- Secure the danger zone by taking suitable protective measures.
- Wear suitable protective equipment.



#### **⚠ CAUTION**

**Injury of the eyes due to dirt particles!**

When cleaning with compressed air, the eyes may be injured by flying dirt particles.

- Wear suitable protective equipment, particularly protective goggles.

#### **NOTICE**

**Possible damage to the product and function restrictions!**

Removing components of the product may disable an additional function or damage the product by allowing an ingress of particles.

- Attachments are only allowed to be removed if this is expressly described in the operating manual or if written approval has been obtained from SCHUNK.

For trouble-free, long-lasting use, clean, maintain and check the functionality of the product regularly.

**Repair work may only be carried out by SCHUNK!**

If you have any questions regarding maintenance and servicing, our technical after-sales service is available during our business hours:

**Service telephone: +49-7133-103-2956**

**service.toolholder@de.schunk.com**

## 8.2 Intervals and tasks

Operation	Interval period
Clean the clamping surface and workpiece stop face	after every clamping procedure
Cleaning the product	daily
Check the expansion rate	weekly or after 1000 clampings
Lubricate the clamping screw and actuating thread	weekly or after 1000 clampings
Polish the clamping surface	weekly or after 1000 clamping operations as required
Disassembly/changing of the intermediate sleeve	for workpiece changes, for maintenance purposes, in the event of damage or signs of wear

The specified maintenance intervals are based on empirical data gathered by SCHUNK and are a recommendation. Depending on the ambient and operating conditions, as well as the clamping frequency of the product, the maintenance intervals need to be adapted and noted accordingly. For maintenance intervals with two or more specifications, the specification that applies first is valid.

After completing essential maintenance work, any settings and functional tests must be carried out again ▶ 6 [📄 20].

### 8.2.1 Clean the clamping surface and workpiece stop face

1. Remove workpiece ▶ 7.3 [📄 29].
2. Make sure that the product is in an unclamped state.
3. Clean clamping face and workpiece stop face with compressed air.
4. Wipe the surfaces dry with a clean cloth.

### 8.2.2 Cleaning the product

1. Remove workpiece ▶ 7.3 [📄 29].
2. Make sure that the product is in an unclamped state.
3. Clean the entire product with compressed air.
4. Carefully remove any stubborn dirt with a suitable tool.
5. Wipe all surfaces dry with a clean cloth.
6. Check the product for deformation, damage or wear, in particular the surfaces that come in contact with the workpiece and replace if necessary.

**NOTE:** Damage or wear can compromise the functioning of the product. If non-replaceable parts of the product are worn or damaged, return the product to SCHUNK for inspection.



### 8.2.3 Check the expansion rate

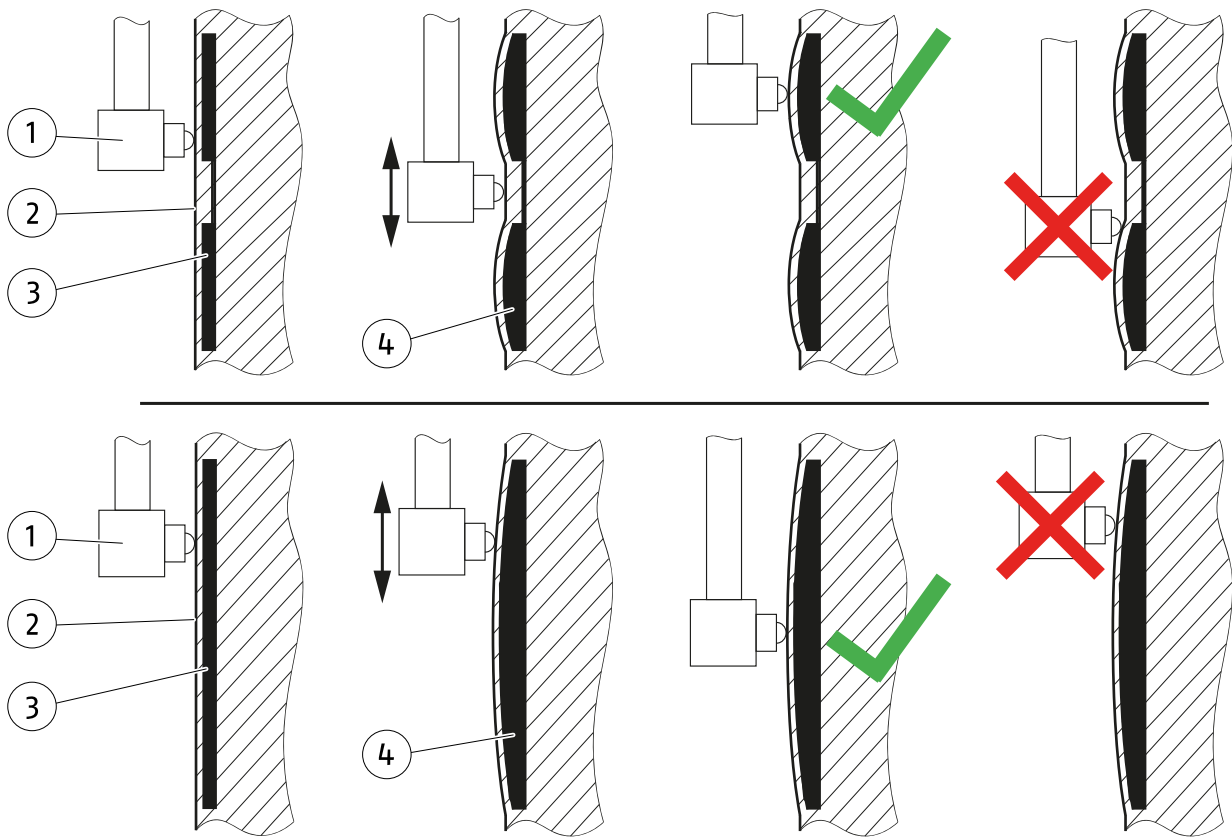

**NOTE:** Illustration is for reference only. Shape of the expansion chamber may differ.

Position	Description
1	Measuring device
2	Clamping surface
3	Expansion chamber (unclamped)
4	Expansion chamber (clamped)

Check the expansion rate according to the information in the maintenance table.

To do this, use a measuring device that meets the following requirements:

- Either two-point inside caliper or dial gauge outside micrometer  
**NOTE:** The measuring device must be spring-loaded!
- Measuring resolution of 0.001 mm
- Analog dial gauge
- Sufficiently large range of measurement (greater than expansion rate)

### 8.2.3.1 Checking the strain rate during manual operation

**CAUTION! Observe the test temperature for the expansion rate check ▶ 3.2 [□ 15]!**

1. Observe the technical data ▶ 3 [□ 14] and the marking on the product.
2. Remove workpiece ▶ 7.3 [□ 29].
3. Make sure that the product is in an unclamped state.
4. Remove the intermediate sleeve ▶ 8.2.6 [□ 48].
5. Clean the clamping surface.
6. Place the measuring device at the center of the clamping surface and set it to zero. **NOTE:** Make sure that the dirt groove (if present) on the clamping surface does not influence the measuring device!
7. Screw the clamping screw in until it reaches the stop.
8. Move the measuring device on the clamping surface until the point with the highest deflection is determined.
9. The difference on the measuring device must match the expansion rate ▶ 3 [□ 14] specified in the technical data.
10. **CAUTION! Clamping screw is not secured against falling out!**  
To unclamp the product, loosen the clamping screw.

If the expansion rate specified in the technical data is not achieved, then

- the hydraulic system has lost too much oil,
- or the clamping diameter is heavily worn.

**In this case, send the product to SCHUNK for inspection.**

### 8.2.3.2 Checking the strain rate during pressure force actuation

**CAUTION!** Observe the test temperature for the expansion rate check ▶ 3.2 [□ 15]!

1. Observe the technical data ▶ 3 [□ 14] and the marking on the product.
2. Remove workpiece ▶ 7.3 [□ 29].
3. Remove the intermediate sleeve if mounted ▶ 8.2.6 [□ 48].
4. Make sure that the product is in an unclamped state.
5. Clean the clamping surface.
6. Place the measuring device at the center of the clamping surface and set it to zero.  
**NOTE:** Make sure that the dirt groove (if present) on the clamping surface does not influence the measuring device!
7. Apply the set actuating force to the product.
8. Move the measuring device on the clamping surface until the point with the highest deflection is determined.
9. The difference on the measuring device must match the expansion rate ▶ 3 [□ 14] specified in the technical data.
10. Return the actuating force of the machine to 0.

If the expansion rate specified in the technical data is not achieved, then

- the hydraulic system has lost too much oil,
- the clamping diameter is heavily worn,
- or the settings of the machine have been changed.

**If the machine settings are unchanged or if a readjustment of the actuating force is unsuccessful, send the product to SCHUNK for inspection.**

## 8.2.4 Lubricate the clamping screw and actuating thread



### ⚠ CAUTION

**Allergic reactions if lubricating grease comes into contact with the skin.**

- Wear protective gloves.

In order to prevent wear to the clamping screw, we recommend that it be lubricated using a method suited to the ambient conditions and the conditions of use. This is especially relevant in case of:

- high clamping frequency
- high operating temperature
- Intensive cleaning

For optimum clamping screw lubrication, we recommend copper paste type MOLYKOTE CU 7439 (100 g tube, ID 9247204).

1. Remove the workpiece ▶ 7.3 [📄 29].
2. Make sure that the product is in an unclamped state.
3. Screw in the clamping screw as far as the stop.
4. Clean the actuating thread; check for any damage or wear to the thread flanks.
5. Lubricate the actuating thread. Use a suitable brush as an aid for this process.
6. Unscrew the clamping screw as far as the lock of the actuating screw.
7. Check the clamping function ▶ 6.3 [📄 24].

### 8.2.5 Polish the clamping surface

If the clamping surface becomes soiled during operation, it can be difficult to insert workpieces. To remove the impurities, the affected surfaces must be polished.

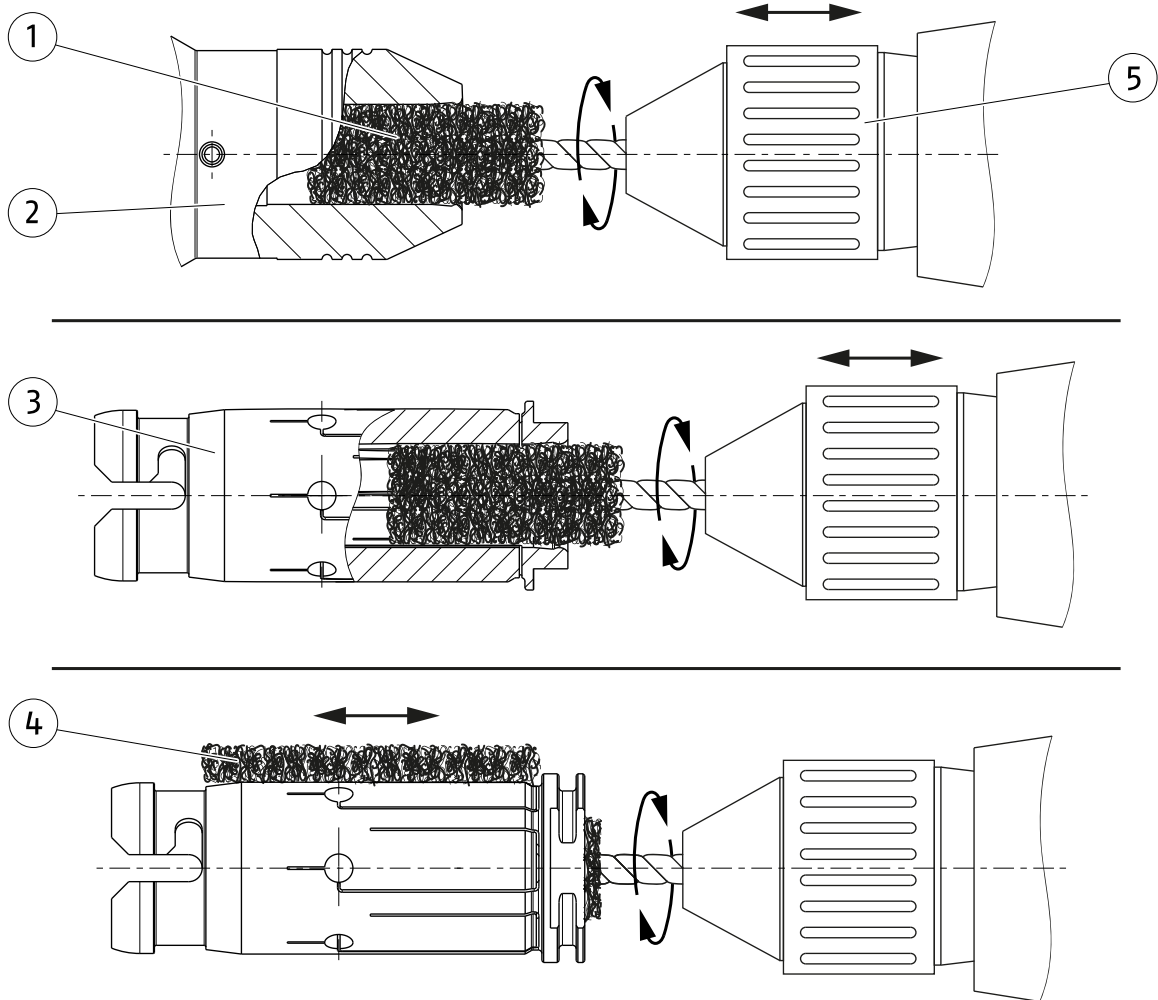

**NOTE:** Illustration is for reference only.

Position	Description
1	Tube brush wrapped with abrasive fleece
2	Product
3	Intermediate sleeve (if present)
4	Abrasive fleece
5	Cordless screwdriver

#### NOTE

If you have any questions regarding polishing, our technical after-sales service is available during our business hours.

**Service telephone: +49-7133-103-2956**  
**service.toolholder@de.schunk.com**

### 8.2.5.1 Polishing the product's clamping surface

1. Remove workpiece ▶ 7.3 [ 29].
2. Make sure that the product is in an unclamped state.
3. If present, remove the: intermediate sleeve ▶ 7.4 [ 30].
4. If present, remove all intermediate sleeve locks such as set-screws.
5. Select a suitable pipe brush. **NOTE:** The diameter of the pipe brush must be 2 mm less than the clamping diameter of the product.
6. Clamp the pipe brush in the cordless screwdriver. Observe the specifications in the cordless screwdriver operating manual.
7. Wrap the abrasive fleece around the pipe brush.
8. Secure product against twisting.
9. Insert the pipe brush wrapped with abrasive fleece into the clamping bore.
10. Actuate cordless screwdriver, thereby
  - ⇒ not exceeding a speed of 1200 RPM and
  - ⇒ move the pipe brush wrapped with the abrasive fleece back and forth several times.
11. Remove the pipe brush wrapped with abrasive fleece from the clamping bore.
12. Clean the clamping bore with a clean cloth and compressed air to remove residue from the polishing process.
13. Insert the test workpiece. **NOTE:** If the test workpiece cannot be inserted smoothly, repeat steps 7 to 12.
14. If required, install intermediate sleeve fuses.
15. If required, install the intermediate sleeve ▶ 7.4 [ 30].

### 8.2.5.2 Polishing the clamping surfaces of the intermediate sleeve

For polishing the bore of the intermediate sleeve:

1. Remove the intermediate sleeve ▶ 7.4 [ 30].
2. Select a suitable pipe brush. **NOTE:** The diameter of the pipe brush must be 2 mm less than the borehole of the intermediate sleeve.
3. Clamp the pipe brush in the cordless screwdriver. Observe the specifications in the cordless screwdriver operating manual.
4. Wrap the abrasive fleece around the pipe brush.
5. Secure the intermediate sleeve against twisting.
6. Insert the pipe brush wrapped with abrasive fleece into the clamping bore.
7. Actuate cordless screwdriver, thereby
  - ⇒ not exceeding a speed of 1200 RPM and
  - ⇒ move the pipe brush wrapped with the abrasive fleece back and forth several times.
8. Clean the clamping bore with a clean cloth and compressed air to remove residue from the polishing process.
9. Remove any dirt stuck in the slots of the intermediate sleeve using a suitable feeler gauge.
10. Insert the test workpiece. **NOTE:** If the test workpiece cannot be inserted easily, repeat steps 4 to 9.
11. Mount intermediate sleeve ▶ 7.4 [ 30].

Polishing the sheath surface of the intermediate sleeve:

1. Remove the intermediate sleeve ▶ 7.4 [📄 30].
2. Select a suitable pipe brush. **NOTE:** The diameter of the pipe brush must be 2 mm less than the borehole of the intermediate sleeve.
3. Clamp the pipe brush in the cordless screwdriver. Observe the specifications in the cordless screwdriver operating manual.
4. Wrap the abrasive fleece around the pipe brush.
5. Insert the pipe brush wrapped with abrasive fleece into the clamping bore.
  - ⇒ The intermediate sleeve is clamped and rotates when the cordless screwdriver is actuated.
6. Actuate cordless screwdriver, thereby
  - ⇒ not exceeding a speed of 1200 RPM.
7. Press the abrasive fleece against the sheath surface and move it back and forth several times.
8. Clean the sheath surface of residue from the polishing procedure using a clean cloth and compressed air.
9. Remove any dirt stuck in the slots of the intermediate sleeve using a suitable feeler gauge.
10. Insert the intermediate sleeve into an unclamped product (e.g. tool grinding chuck). **NOTE:** If the intermediate sleeve cannot be inserted easily, repeat steps 4 to 9 or check the clamping bore of the product and polish if necessary.
11. Mount intermediate sleeve ▶ 7.4 [📄 30].

### 8.2.6 Disassembly/changing of the intermediate sleeve

Any inserted intermediate sleeve must be disassembled for maintenance. If there are signs of wear or damage, the intermediate sleeve must be replaced.

**NOTICE! Only change the intermediate sleeve when the product is unclamped!**

#### 8.2.6.1 Intermediate sleeve without lock

##### Disassembly

1. Remove workpiece ▶ 7.3 [📄 29].
2. Make sure that the product is in an unclamped state.
3. Carefully and evenly pull out the intermediate sleeve, keeping it parallel. For this purpose, we recommend the use of a sleeve remover.

##### Assembly

1. Return the actuating force of the machine to 0.
2. Make sure that the product is in an unclamped state.
3. Place the intermediate sleeve on the product in the correct position and fit it as far as the stop without exerting too much force.

### 8.2.6.2 Intermediate sleeve with lock via set-screw

#### Disassembly

1. Remove workpiece ▶ 7.3 [📄 29].
2. Make sure that the product is in an unclamped state.
3. Unscrew the set-screw.
4. Carefully and evenly pull out the intermediate sleeve, keeping it parallel. For this purpose, we recommend the use of a sleeve remover.

**NOTICE! If no other intermediate sleeve is fitted after disassembly, unscrew the set-screw completely.**

#### Assembly

1. Return the actuating force of the machine to 0.
2. Make sure that the product is in an unclamped state.
3. Place the intermediate sleeve onto the product in the correct position and fit it as far as the stop without exerting too much force, ensuring it remains parallel.

**IMPORTANT! Make sure that the bore hole of the intermediate sleeve matches the position of the bore hole of the set-screw. Otherwise the intermediate sleeve cannot be secured.**

4. Screw in the set-screw only so far that the intermediate sleeve cannot be removed, but still has some clearance.

**IMPORTANT! If the set-screw is screwed in too far, the workpiece loading will be obstructed and run-out errors may occur!**

## 9 Troubleshooting

Malfunction/error	Possible cause	Solution(s)
Workpiece is not clamped	Intermediate sleeve not mounted	Mount intermediate sleeve ▶ 7.4 [ 30]
	The machine settings have been changed	Check actuating force ▶ 6.2 [ 22]
	Wear on the clamping diameter	Send the product to SCHUNK for inspection
	Oil loss on the product	Send the product to SCHUNK for inspection
Workpiece cannot be joined	Product is not completely unclamped	Unclamping the product ▶ 7.3 [ 29]
	Adjustment screw is screwed in too far	Unscrew the adjustment screw slightly.
	Solidified dirt on the clamping surface	Polish the clamping surface ▶ 8.2.5 [ 44]
Workpiece cannot be removed	Product is not completely unclamped	Unclamping the product ▶ 7.3 [ 29]
	Adjustment screw is screwed in too far	Unscrew the adjustment screw slightly.
Insufficient run-out accuracy	If intermediate sleeve is secured with a set-screw: set-screw screwed in too far	Unscrew the set-screw slightly.
	Product is not correctly positioned on the machine interface	Clean the contact surfaces of the product and machine
	With flange mounting: mounting screws are not tightened correctly	Adhere to the specified tightening torque ▶ 3 [ 14]

If you have any questions regarding troubleshooting, our technical after-sales service is available during our business hours:

**Service telephone: +49-7133-103-2956**  
**service.toolholder@de.schunk.com**

## 10 Disassembly

### 10.1 Basic information



#### ⚠ WARNING

##### **Risk of injury if the product falls during transport, assembly or disassembly!**

Due to the oily surface required to preserve it, the product can slip through your hands, resulting in injury.

- Take appropriate safety measures to prevent the product from falling.
- Only install the product on machines with the appropriate connection dimensions.
- Wear suitable protective equipment, especially safety gloves.



#### ⚠ CAUTION

##### **Risk of crushing and impact when assembling and disassembling the product!**

- Do not reach between the product and machine.
- Wear suitable protective equipment.

#### NOTICE

##### **Possible damage to the expansion sleeve!**

- When transporting and handling the product, ensure that it is not damaged by knocks, impacts, etc.
- It is essential that the thin-walled clamping face (expansion sleeve) is protected against shocks and impacts.

### 10.2 Disassembly of the product

1. Remove workpiece ▶ 7.3 [📄 29].
2. Make sure that the product is in an unclamped state.
3. Secure the product against falling down.
4. Unscrew the mounting screws of the product.
5. Remove the product.

**NOTE:** To avoid damage, only place the product on a clean and soft surface.

## 11 Storage

When storing the product for a longer period of time, observe the following points:

- Ensure that the product is in an unclamped state.
- Clean and lightly oil the product and intermediate sleeve.
- Store the product and intermediate sleeve in a suitable transport container.
- Only store the product and intermediate sleeve in dry rooms.
- Protect the product and intermediate sleeve from excessive temperature fluctuations.
- Comply with the storage temperature specified in the technical data.

**NOTE:** Before reassembling, clean the product and all attachments ▶ 8.2.2 [ 38], and check for damage, functionality and tightness. After assembly, all settings and function tests must be carried out ▶ 6 [ 20].

## 12 Disposal

When disposing of the product, observe the following points:

- Collect any escaping liquids and dispose of them properly in line with the statutory provisions.
- Follow local regulations on dispatching product components for recycling or proper disposal.

**NOTE:** Alternatively, you can return the product to SCHUNK for correct disposal.

## 13 Drawings

The assembly and operating manual as well as the valid drawing can be requested in digital format by stating the product ID.

For this, contact our technical after-sales service:

**[service.toolholder@de.schunk.com](mailto:service.toolholder@de.schunk.com)**

## 14 Declaration of incorporation

in terms of the Directive 2006/42/EG, Annex II, Part 1 Section B.

Manufacturer/ Distributor                      SCHUNK SE & Co. KG  
Spanntechnik | Greiftechnik | Automatisierungstechnik  
Bahnhofstr. 106 – 134  
D-74348 Lauffen/Neckar

We hereby declare that the partly completed machine described below

Product designation:                      Tool grinding toolholder  
ID:    0206766; 0206767; 0206768; 0206769

It is hereby declared that the following essential requirements of the Machinery Directive 2006/42/EC are fulfilled. 1.1.1, 1.1.5, 1.3.4, 1.6.1

meets the following basic occupational health and safety of the Machinery Directive 2006/42/EC:

No. 1.1.1, No. 1.1.2, No. 1.1.3, No. 1.1.5, No. 1.3.2, No. 1.5.3, No. 1.5.4, No. 1.5.6, No. 1.5.8, No. 1.5.10, No. 1.5.11, No. 1.5.13

The partly completed machinery may not be put into operation until it has been confirmed that the machine into which the partly completed machinery is to be installed complies with the provisions of the Machinery Directive (2006/42/EC). The declaration shall be rendered invalid if modifications are made to the product.

Applied harmonized standards, especially:

EN ISO 12100:2010                      Safety of machinery – General principles for design –  
Risk assessment and risk reduction

The special technical documentation according to Annex VII, Part B, belonging to the partly completed machine, has been created.

Person authorized to compile the technical documentation:  
Stefanie Walter, Address: see manufacturer's address

*Signature: see original declaration*

Lauffen/Neckar, November 2022

p.p. Fatih Gülgönül;  
Head of Engineering



**SCHUNK SE & Co. KG**  
Spanntechnik | Greiftechnik | Automatisierungstechnik

Bahnhofstr. 106 – 134  
D-74348 Lauffen/Neckar  
Tel. +49-7133-103-0  
info@de.schunk.com  
schunk.com

Folgen Sie uns | *Follow us*



Wir drucken nachhaltig | *We print sustainable*