

# Assembly and Operating Manual

## PHL

### 2-finger parallel gripper

Translation of original operating  
manual

## Imprint

### Copyright:

This manual is protected by copyright. The author is SCHUNK SE & Co. KG.  
All rights reserved.

### Technical changes:

We reserve the right to make alterations for the purpose of technical improvement.

**Document number:** 1552150

**Version:** 06.00 | 27/08/2025 | en

Dear Customer,

Thank you for trusting our products and our family-owned company, the leading technology supplier of robots and production machines.

Our team is always available to answer any questions on this product and other solutions. Ask us questions and challenge us. We will find a solution!

Best regards,

Your SCHUNK team

Customer Management

Tel. +49-7133-103-2500

Fax +49-7133-103-2239

cms@de.schunk.com



**Please read the operating manual in full and keep it close to the product.**

## Table of Contents

<b>1 General</b>	<b>5</b>
1.1 About this manual	5
1.1.1 Presentation of Warning Labels	5
1.1.2 Applicable documents	6
1.1.3 Sizes	6
1.1.4 Variants	6
1.2 Warranty	6
1.3 Scope of delivery	6
1.4 Accessories	8
<b>2 Basic safety notes</b>	<b>9</b>
2.1 Intended use	9
2.2 Constructional changes	9
2.3 Spare parts	9
2.4 Gripper fingers	10
2.5 Ambient conditions and operating conditions	10
2.6 Personnel qualification	10
2.7 Personal protective equipment	11
2.8 Notes on safe operation	12
2.9 Transport	12
2.10 Malfunctions	12
2.11 Disposal	13
2.12 Fundamental dangers	13
2.12.1 Protection during handling and assembly	13
2.12.2 Protection during commissioning and operation	14
2.12.3 Protection against dangerous movements	14
2.13 Notes on particular risks	15
<b>3 Technical data</b>	<b>17</b>
3.1 Name plate	17
3.2 Basic data	18
<b>4 Design and description</b>	<b>19</b>
4.1 Design	19
4.2 Description	19
<b>5 Assembly</b>	<b>20</b>
5.1 Mechanical connection	20
5.2 Assembly of the top jaws	22
5.3 Pneumatic connection	23

5.4	Mounting the sensor .....	25
5.4.1	Overview of sensors .....	25
5.4.2	Mounting inductive proximity switch IN 80 .....	26
5.4.3	Installing the magnetic switch MMS 22 / RMS 22.....	28
5.4.4	Mount the programmable magnetic switch MMS 22-PI1.....	30
5.4.5	Mounting the Balluff BIP inductive analog position sensor .....	31
<b>6</b>	<b>Troubleshooting.....</b>	<b>32</b>
6.1	Gripper does not move .....	32
6.2	Gripper does not execute a complete stroke.....	32
6.3	Product is opening or closing abruptly .....	32
6.4	Gripping force is dropping.....	33
6.5	Product does not achieve the opening and closing times .....	33
<b>7</b>	<b>Maintenance .....</b>	<b>34</b>
7.1	Notes.....	34
7.1.1	Exchanging the rail and base jaws .....	34
7.1.2	Maintenacnce of module with gripping force maintenance .....	34
7.2	Maintenance and lubrication intervals.....	34
7.3	Lubricants/Lubrication points (basic lubrication) .....	35
7.4	Disassembly and assembly .....	37
7.4.1	Version without gripping force maintenance .....	37
7.4.2	Variant with gripping force maintenance .....	37
7.5	Servicing and assembling the product .....	40
7.5.1	Torque for screws [Nm].....	40
7.6	Assembly drawing .....	41
<b>8</b>	<b>Translation of the original declaration of incorporation .....</b>	<b>42</b>
<b>9</b>	<b>Information on the RoHS Directive, REACH Regulation and Substances of Very High Concern (SVHC) .....</b>	<b>43</b>
<b>10</b>	<b>UKCA declaration of incorporation .....</b>	<b>44</b>

# 1 General

## 1.1 About this manual

This manual contains important information for a safe and appropriate use of the product.

This manual is an integral part of the product and must be kept accessible for the personnel at all times.

Before starting work, the personnel must have read and understood this operating manual. Prerequisite for safe working is the observance of all safety instructions in this manual.

In addition to these instructions, the documents listed under ▶ 1.1.2 [ 6 ] are applicable.

**NOTE:** The illustrations in this manual are intended to provide a basic understanding and may deviate from the actual version.

### 1.1.1 Presentation of Warning Labels

To make risks clear, the following signal words and symbols are used for safety notes.



#### **⚠ DANGER**

**Dangers for persons!**

Non-observance will inevitably cause irreversible injury or death.



#### **⚠ WARNING**

**Dangers for persons!**

Non-observance can lead to irreversible injury and even death.



#### **⚠ CAUTION**

**Dangers for persons!**

Non-observance can cause minor injuries.

#### **NOTICE**

**Material damage!**

Information about avoiding material damage.

### 1.1.2 Applicable documents

- General terms of business \*
- Catalog data sheet of the purchased product \*
- Assembly and operating manuals of the accessories \*

The documents labeled with an asterisk (\*) can be downloaded from [schunk.com/downloads](https://www.schunk.com/downloads).

### 1.1.3 Sizes

This operating manual applies to the following sizes:

- PHL 25
- PHL 32
- PHL 40
- PHL 50
- PHL 63

### 1.1.4 Variants

This operating manual applies to the following variations:

- PHL with gripping force maintenance (-S)
- PHL FKM seal version (-V)

## 1.2 Warranty

If the product is used as intended, the warranty is valid for 24 months from the ex-works delivery date under the following conditions:

- Observe the specified maintenance and lubrication intervals
- Observe the ambient conditions and operating conditions

Parts touching the workpiece and wear parts are not included in the warranty.

## 1.3 Scope of delivery

The scope of delivery includes

- 2-finger parallel gripper PHL in the version ordered
- Safety information (product-specific instructions available online)
- Accessory pack

Content of the accessory pack:

- 2x centering sleeve for gripper fastening
- 4x centering sleeve for finger fastening
- 2 x O-ring for hose-free direct connection

**ID.-No. of the accessory pack**

<b>Size</b>	<b>ID number</b>
25	5521123
25-V	395521123
32	5521124
32-V	395521124
40	5521125
40-V	395521125
50	5521126
50-V	1006262
63	5521127
63-V	395521127

*Tab.: ID.-No. of the accessory pack*

## 1.4 Accessories

A wide range of accessories are available for this product  
For information regarding which accessory articles can be used  
with the corresponding product variants, see catalog data sheet.

Content of the sealing kit:

- 4x gasket
- 4x O-ring
- 4x Quad ring (Size 25)
- 4x cylinder seal (Size 32, 40 ,50, 63)

### ID.-No. of the seal kit

Size	ID number
25	5522673
32	5522674
40	5522675
50	5522676
63	5522677
25-V	5522678
32-V	5522679
40-V	5522680
50-V	5522681
65-V	5522682

Tab.: ID. No. spare part kit "Seal kit"

## 2 Basic safety notes

### 2.1 Intended use

The product is designed exclusively for gripping and temporarily holding workpieces or objects.

- The product may only be used within the scope of its technical data, ▶ 3 [17].
- The product is intended for installation in a machine/ automated system. The applicable guidelines for the machine/ automated system must be observed and complied with.
- The product is intended for industrial and industry-oriented use. Its use outside enclosed spaces is only permitted if suitable protective measures are taken against outdoor exposure. The product is not suitable for use in salty air.
- The product can be used within the permissible load limits and technical data for holding workpieces during simple machining operations, but is not a clamping device according to EN 1550:1997+A1:2008.
- Appropriate use of the product includes compliance with all instructions in this manual.
- Any utilization that exceeds or differs from the appropriate use is regarded as misuse.

### 2.2 Constructional changes

#### Implementation of structural changes

Modifications, changes or reworking, e.g. additional threads, holes, or safety devices, can damage the product or impair its functionality or safety.

- Structural changes should only be made with the written approval of SCHUNK.

### 2.3 Spare parts

#### Use of unauthorized spare parts

Using unauthorized spare parts can endanger personnel and damage the product or cause it to malfunction.

- Use only original spare parts or spares authorized by SCHUNK.

## 2.4 Gripper fingers

### Requirements for the gripper fingers

Accumulated energy can make the product unsafe and risk the danger of serious injuries and considerable material damage.

- Only change gripper fingers if no residual energy can be released.
- Make sure that the product and the top jaws are a sufficient size for the application.

## 2.5 Ambient conditions and operating conditions

### Required ambient conditions and operating conditions

Incorrect ambient and operating conditions can make the product unsafe, leading to the risk of serious injuries, considerable material damage and/or a significant reduction to the product's life span.

- Make sure that the product is used only in the context of its defined application parameters, ► 3 [📄 17].

## 2.6 Personnel qualification

### Inadequate qualifications of the personnel

If the personnel working with the product is not sufficiently qualified, the result may be serious injuries and significant property damage.

- All work may only be performed by qualified personnel.
- Before working with the product, the personnel must have read and understood the complete assembly and operating manual.
- Observe the national safety regulations and rules and general safety instructions.

The following personal qualifications are necessary for the various activities related to the product:

<b>Trained electrician</b>	Due to their technical training, knowledge and experience, trained electricians are able to work on electrical systems, recognize and avoid possible dangers and know the relevant standards and regulations.
<b>Qualified personnel</b>	Due to its technical training, knowledge and experience, qualified personnel is able to perform the delegated tasks, recognize and avoid possible dangers and knows the relevant standards and regulations.
<b>Instructed person</b>	Instructed persons were instructed by the operator about the delegated tasks and possible dangers due to improper behaviour.
<b>Service personnel of the manufacturer</b>	Due to its technical training, knowledge and experience, service personnel of the manufacturer is able to perform the delegated tasks and to recognize and avoid possible dangers.

## 2.7 Personal protective equipment

### Use of personal protective equipment

Personal protective equipment serves to protect staff against danger which may interfere with their health or safety at work.

- When working on and with the product, observe the occupational health and safety regulations and wear the required personal protective equipment.
- Observe the valid safety and accident prevention regulations.
- Wear protective gloves to guard against sharp edges and corners or rough surfaces.
- Wear heat-resistant protective gloves when handling hot surfaces.
- Wear protective gloves and safety goggles when handling hazardous substances.
- Wear close-fitting protective clothing and also wear long hair in a hairnet when dealing with moving components.

## 2.8 Notes on safe operation

### Incorrect handling of the personnel

Incorrect handling and assembly may impair the product's safety and cause serious injuries and considerable material damage.

- Avoid any manner of working that may interfere with the function and operational safety of the product.
- Use the product as intended.
- Observe the safety notes and assembly instructions.
- Do not expose the product to any corrosive media. This does not apply to products that are designed for special environments.
- Eliminate any malfunction immediately.
- Observe the care and maintenance instructions.
- Observe the current safety, accident prevention and environmental protection regulations regarding the product's application field.

## 2.9 Transport

### Handling during transport

Incorrect handling during transport may impair the product's safety and cause serious injuries and considerable material damage.

- When handling heavy weights, use lifting equipment to lift the product and transport it by appropriate means.
- Secure the product against falling during transportation and handling.
- Stand clear of suspended loads.

## 2.10 Malfunctions

### Behavior in case of malfunctions

- Immediately remove the product from operation and report the malfunction to the responsible departments/persons.
- Order appropriately trained personnel to rectify the malfunction.
- Do not recommission the product until the malfunction has been rectified.
- Test the product after a malfunction to establish whether it still functions properly and no increased risks have arisen.

## 2.11 Disposal

### Handling of disposal

The incorrect handling of disposal may impair the product's safety and cause serious injuries as well as considerable material and environmental harm.

- Follow local regulations on dispatching product components for recycling or proper disposal.

## 2.12 Fundamental dangers

### General

- Observe safety distances.
- Never deactivate safety devices.
- Before commissioning the product, take appropriate protective measures to secure the danger zone.
- Disconnect power sources before installation, modification, maintenance, or calibration. Ensure that no residual energy remains in the system.
- If the energy supply is connected, do not move any parts by hand.
- Do not reach into the open mechanism or movement area of the product during operation.

### 2.12.1 Protection during handling and assembly

#### Incorrect handling and assembly

Incorrect handling and assembly may impair the product's safety and cause serious injuries and considerable material damage.

- Have all work carried out by appropriately qualified personnel.
- For all work, secure the product against accidental operation.
- Observe the relevant accident prevention rules.
- Use suitable assembly and transport equipment and take precautions to prevent jamming and crushing.

#### Incorrect lifting of loads

Falling loads may cause serious injuries and even death.

- Stand clear of suspended loads and do not step into their swiveling range.
- Never move loads without supervision.
- Do not leave suspended loads unattended.

## 2.12.2 Protection during commissioning and operation

### Falling or violently ejected components

Falling and violently ejected components can cause serious injuries and even death.

- Take appropriate protective measures to secure the danger zone.
- Never step into the danger zone during operation.

## 2.12.3 Protection against dangerous movements

### Unexpected movements

Residual energy in the system may cause serious injuries while working with the product.

- Switch off the energy supply, ensure that no residual energy remains and secure against inadvertent reactivation.
- Never rely solely on the response of the monitoring function to avert danger. Until the installed monitors become effective, it must be assumed that the drive movement is faulty, with its action being dependent on the control unit and the current operating condition of the drive. Perform maintenance work, modifications, and attachments outside the danger zone defined by the movement range.
- To avoid accidents and/or material damage, human access to the movement range of the machine must be restricted. Limit/prevent accidental access for people in this area due through technical safety measures. The protective cover and protective fence must be rigid enough to withstand the maximum possible movement energy. EMERGENCY STOP switches must be easily and quickly accessible. Before starting up the machine or automated system, check that the EMERGENCY STOP system is working. Prevent operation of the machine if this protective equipment does not function correctly.

## 2.13 Notes on particular risks



### **⚠ DANGER**

#### **Risk of fatal injury from suspended loads!**

Falling loads can cause serious injuries and even death.

- Stand clear of suspended loads and do not step within their swiveling range.
- Never move loads without supervision.
- Do not leave suspended loads unattended.
- Wear suitable protective equipment.



### **⚠ WARNING**

#### **Risk of injury from objects falling and being ejected!**

Falling and ejected objects during operation can lead to serious injury or death.

- Take appropriate protective measures to secure the danger zone.



### **⚠ WARNING**

#### **Risk of injury from sharp edges and corners!**

Sharp edges and corners can cause cuts.

- Use suitable protective equipment.



### **⚠ WARNING**

#### **Risk of injury due to unexpected movements!**

If the power supply is switched on or residual energy remains in the system, components can move unexpectedly and cause serious injuries.

- Before starting any work on the product: Switch off the power supply and secure against restarting.
- Make sure, that no residual energy remains in the system.



### **⚠ WARNING**

#### **Risk of injury from crushing and impacts!**

Serious injury could occur during movement of the base jaw, due to breakage or loosening of the gripper fingers or if the workpiece is lost.

- Wear suitable protective equipment.
- Do not reach into the open mechanism or the movement area of the product.



### **⚠ WARNING**

#### **Risk of injury due to spring forces!**

Parts are under spring tension on products which clamp using spring force or which have gripping force maintenance. While disassembling components can move unexpectedly and cause serious injuries.

- Disassemble the product cautiously.
- Make sure that no residual energy remains in the system.



### **⚠ WARNING**

#### **Risk of injury from objects falling during energy supply failure**

Products with a mechanical gripping force maintenance can, during energy supply failure, still move independently in the direction specified by the mechanical gripping force maintenance.

- Secure the end positions of the product with SCHUNK SDV-P pressure maintenance valves.

### 3 Technical data

#### 3.1 Name plate

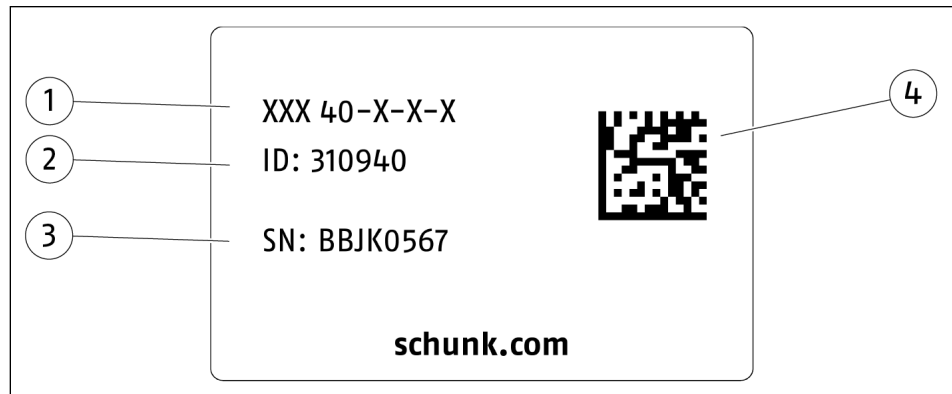

1 Product designation

2 ID

3 Serial number

4 Data matrix code

Scan code or enter serial number on the web and get all the product information: operating manuals, spare parts packages, software updates and much more.

For further information, visit [schunk.com/serialisierung](https://www.schunk.com/serialisierung)

A separate app may be required for scanning with a mobile phone.

### 3.2 Basic data

#### Connection data

Pressure medium	Compressed air, compressed air quality according to ISO 8573-1:2010 [7:4:4]
Nominal operating pressure [bar]	6
Minimum pressure [bar] without maintenance of gripping force	2
Minimum pressure [bar] with maintenance of gripping force	4
Maximum pressure [bar] without maintenance of gripping force	8
Maximum pressure [bar] with maintenance of gripping force	6.5

#### Ambient conditions and operating conditions

#### Designation

Ambient temperature [°C]	
min.	+5
max.	+90
Protection class IP *	41
Noise emission [dB(A)]	≤ 70

\* For use in dirty ambient conditions (e.g. sprayed water, vapors, abrasion or processing dust) SCHUNK offers corresponding product options as standard. SCHUNK also offers customized solutions for special applications in dirty ambient conditions.

More technical data is included in the catalog data sheet. Whichever is the latest version.

## 4 Design and description

### 4.1 Design

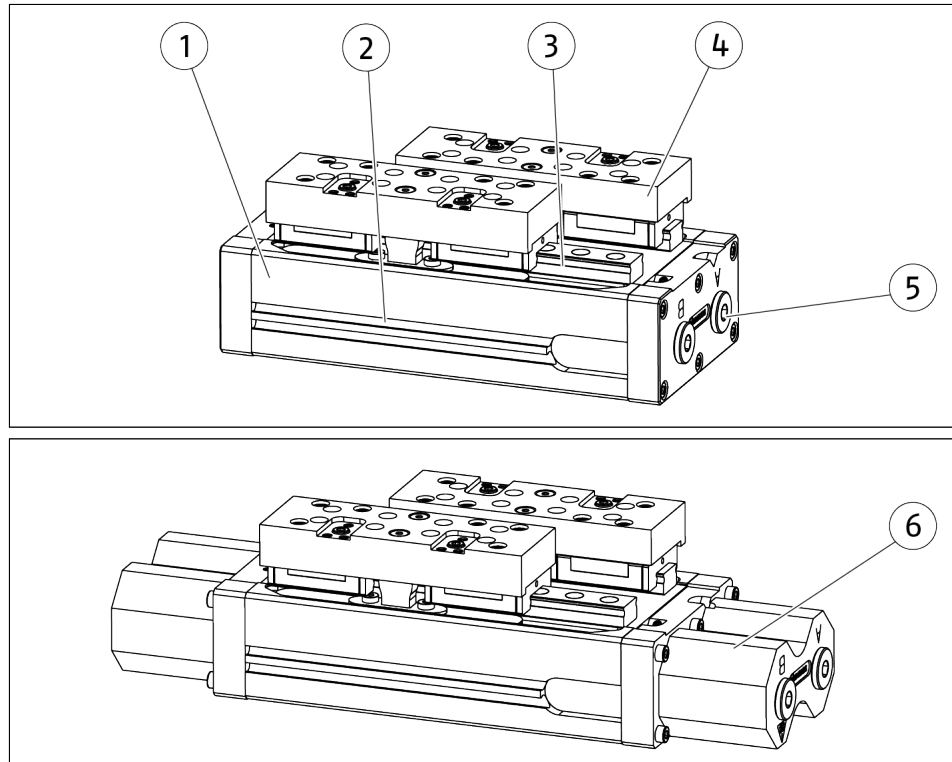

- |   |                                                |
|---|------------------------------------------------|
| 1 | Housing                                        |
| 2 | Groove for sensors                             |
| 3 | Linear guide                                   |
| 4 | Base jaw                                       |
| 5 | Compressed air main connection                 |
| 6 | Variant with gripping force maintenance device |

### 4.2 Description

2-finger parallel gripper with long jaw stroke for large parts and/or a broad range of parts.

## 5 Assembly

### 5.1 Mechanical connection



#### **⚠ WARNING**

##### **Risk of injury due to unexpected movements!**

If the power supply is switched on or residual energy remains in the system, components can move unexpectedly and cause serious injuries.

- Before starting any work on the product: Switch off the power supply and secure against restarting.
- Make sure, that no residual energy remains in the system.

#### **Evenness of the mounting surface**

The values apply to the whole mounting surface to which the product is mounted.

<b>Edge length</b>	<b>Permissible unevenness</b>
< 100	< 0.02
> 100	< 0.05

*Tab.: Requirements for evenness of the mounting surface (Dimensions in mm)*

#### **Mounting**

The product can be mounted in 2 different ways:

- A: Screws (1) are screwed through the housing.
- B: Screws (2) are screwed in the thread.

The centering sleeves (3) are included in the accessory kit.

#### **NOTICE**

##### **Observe the minimum depth of engagement during assembly.**

- The minimum depth of engagement is equal to 1.5 times the thread diameter.

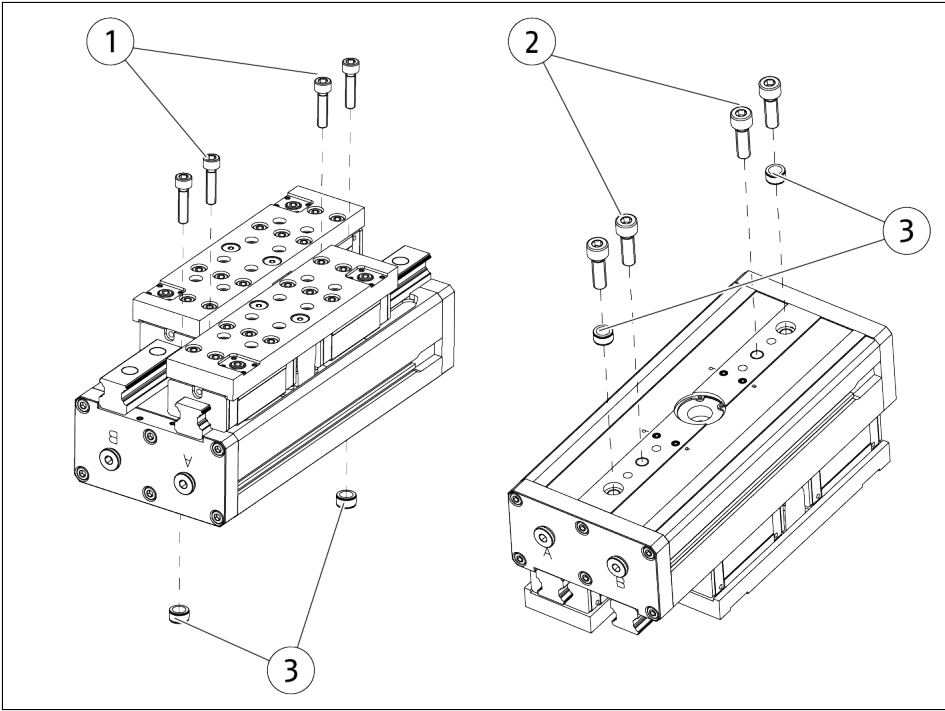

Size	① Thread diameter for mounting A	② Thread diameter for mounting B *
25	M4	M5 / 14
32	M5	M6 / 16
40	M6	M8 / 18
50	M6	M8 / 18
63	M8	M10 / 20

\* Thread/length of thread in the housing [mm]

## 5.2 Assembly of the top jaws

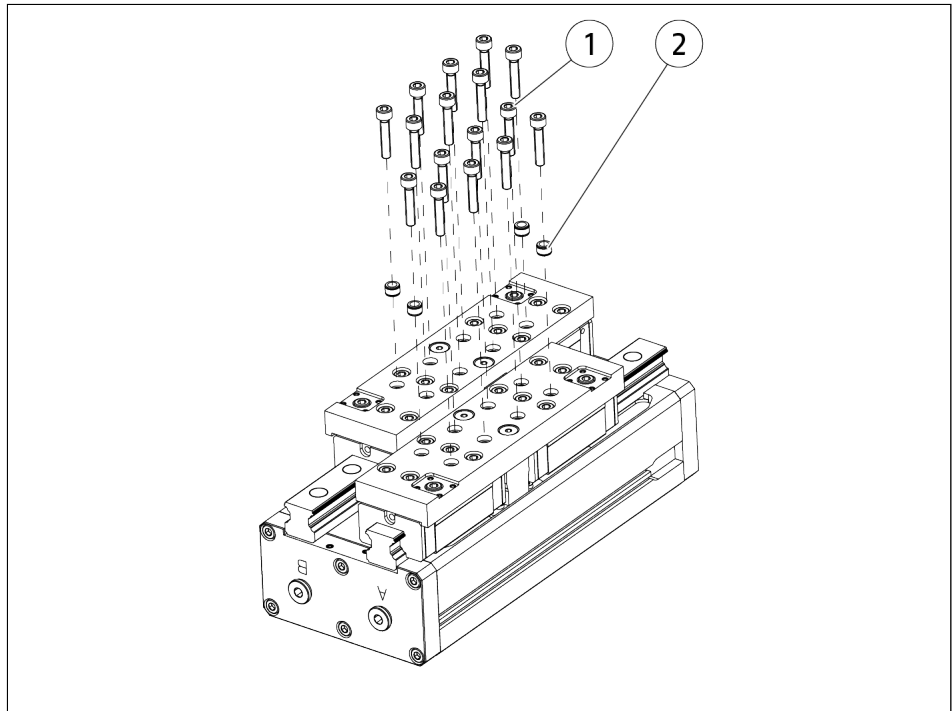

The centering sleeves (2) are included in the scope of delivery. The screws (1) for mounting the top jaws must be provided by the customer:

### NOTICE

**The gripper will be damaged if the maximum depth of engagement is exceeded in the base jaw.**

The minimum depth of engagement is equal to 1.5 times the thread diameter.

Size	Thread diameter	Max. screw-in depth for finger fastening [mm]	Minimum number of mounting screws per jaw [piece]	Maximum tightening torque [Nm]
25	M4	8	6	5.3
32	M4	8	6	5.3
40	M5	10	6	11
50	M6	13.5	6	18
63	M8	16	8	43

### 5.3 Pneumatic connection



#### **⚠ WARNING**

##### **Risk of injury due to unexpected movements!**

If the power supply is switched on or residual energy remains in the system, components can move unexpectedly and cause serious injuries.

- Before starting any work on the product: Switch off the power supply and secure against restarting.
- Make sure, that no residual energy remains in the system.

#### **NOTICE**

##### **Risk of damage to the gripper!**

If the maximum permissible finger weight or the permissible mass moment of inertia of the fingers is exceeded, the gripper can be damaged.

- As a rule, a jaw movement must take place without impact and bouncing.
- To do this, carry out sufficient throttling and/or damping if necessary.
- Observe specifications in the catalog data sheet.

#### **NOTE**

- Observe the requirements for the compressed air supply, ▶ 3 [17].
- In case of compressed air loss (cutting off the energy line), the components lose their dynamic effects and do not remain in a secure position. However, the use of a SDV-P pressure maintenance valve is recommended in this case in order to maintain the dynamic effect for some time. Product variants are also offered with mechanical gripping force via springs, which also ensure a minimum clamping force in the event of a pressure drop.
- Open only the air connections that are needed.
- Close unused main air connections using the screw plugs from the enclosed pack.
- For a hose-free direction connection, use the O-rings from the enclosed pack.
- When using own-design top jaws, make sure that main connection A opens the gripper and B closes it.

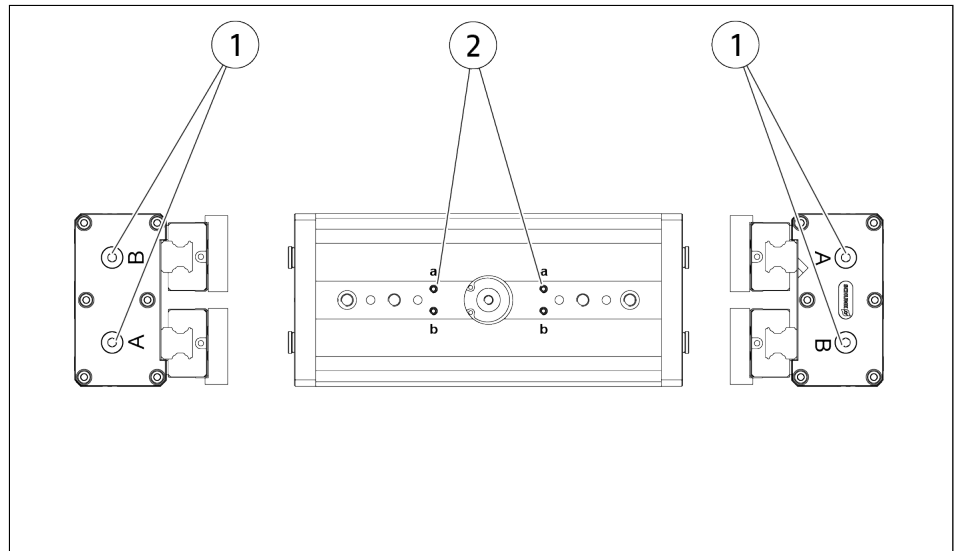

*Pneumatic connection*

**NOTICE! Risk of damage to the product! Only use one of the two main connections (A, B) at a time.**

- 
- 1 Main connections (hose connection)  
(A = open, B = close)
- 
- 2 Hose-free direct connection (floor side)  
(a = open, b = close)
-

## 5.4 Mounting the sensor

### NOTE

Observe the assembly and operating manual of the sensor for mounting and connecting.

The product is prepared for the use of sensors.

- For the exact type designations of suitable sensors, please see catalog datasheet and ▶ 5.4.1 [📄 25].
- For technical data for the suitable sensors, see assembly and operating manual and catalog datasheet.
  - The assembly and operating manual and catalog datasheet are included in the scope of delivery for the sensors and are available at schunk.com.
- Information on handling sensors is available at schunk.com or from SCHUNK contact persons.

### 5.4.1 Overview of sensors

Size	IN 80	MMS 22	RMS 22	MMS 22-PI1	BIP
25	✓	✓	⊘	✓	✓
32	✓	✓	⊘	✓	✓
40	✓	✓	✓	✓	✓
50	✓	✓	⊘	✓	✓
63	✓	✓	⊘	✓	✓ *

\* not for PHL 63-160

### 5.4.2 Mounting inductive proximity switch IN 80

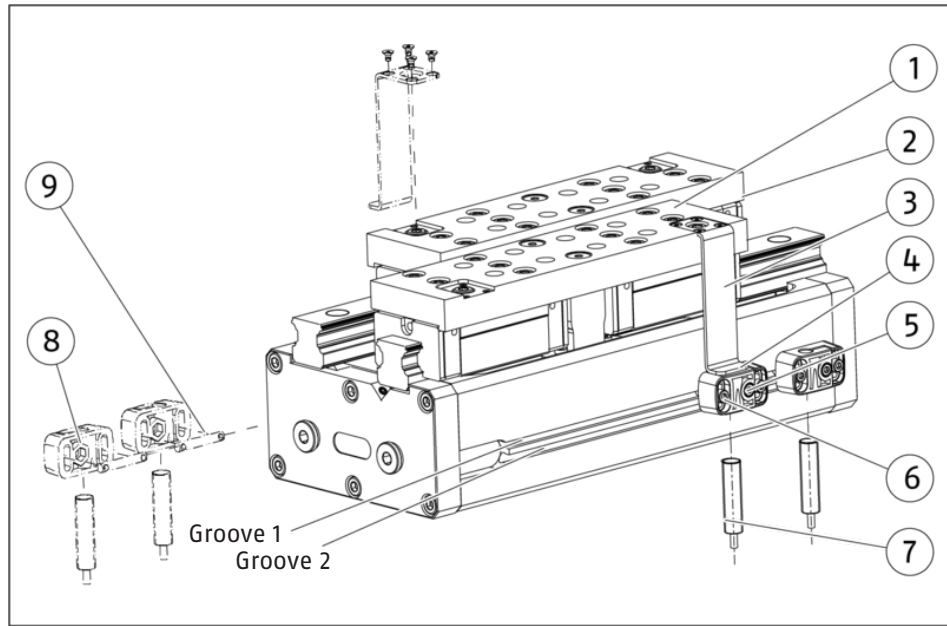

Size	Groove 1	Groove 2
25	X	–
32	X	–
40	–	X
50	X	–
63	X	–

#### Position "Gripper open" or "Part gripped (I.D. gripping)":

1. Move product to the "gripper open" position.
2. Fasten the control cam (3) to the base jaw (1) using screws (2).
3. Slide the sensor (7) into the bracket (4) to the stop.
4. Insert hexagon nut (8) on the rear of the bracket (4).
5. Fix the sensor with the attachment screw (5) and nut (8).  
⇒ The sensor is fastened in the bracket.
6. Slide T-nut (9) and bracket (4) into one of the grooves of the housing (see table).
7. Slide sensor (including bracket and T-nut) from the side on which the base jaw is located, with minimum distance to the control cam in the direction of the gripper center until the sensor switches.  
⇒ The position of the sensor (including bracket) in the groove is set.
8. Increase the distance between sensor (including bracket) in this position and control cam until the sensor no longer switches.

9. Push sensor (including bracket) towards the control cam until the sensor switches.

⇒ The distance of the sensor (including bracket) to the control cam is set.

10. Tighten the bracket (4) in this position using screws (6).  
Tightening torque: 20 Ncm

11. Bring product into the "gripper open" or "gripper closed" position and test the functioning.

**Position "Gripper closed" or "Part gripped (O.D. gripping)":**

1. Move product to the "gripper closed" position.

2. Fasten the control cam (3) to the base jaw (1) using screws (2).

3. Slide the sensor (7) into the bracket (4) to the stop.

4. Insert hexagon nut (8) on the rear of the bracket (4).

5. Fix the sensor with the attachment screw (5) and nut (8).

⇒ The sensor is fastened in the bracket.

6. Slide T-nut (9) and bracket (4) into one of the grooves of the housing (see table).

7. Slide sensor (including bracket and T-nut) outwards from the center of the gripper at minimum distance to the control cam until the sensor switches.

⇒ The position of the sensor (including bracket) in the groove is set.

8. Increase the distance between sensor (including bracket) in this position and control cam until the sensor no longer switches.

9. Push sensor (including bracket) towards the control cam until the sensor switches.

⇒ The distance of the sensor (including bracket) to the control cam is set.

10. Tighten the bracket (4) in this position using screws (6).  
Tightening torque: 20 Ncm

11. Bring product into the "gripper open" or "gripper closed" position and test the functioning.

### 5.4.3 Installing the magnetic switch MMS 22 / RMS 22

#### NOTICE

#### Risk of damage to the sensor during assembly!

- Observe the maximal tightening torque.

#### NOTE

**Ferromagnetic material changes the switching positions of the sensor. For example: Adapter plate made of ordinary steel.**

At ferromagnetic adapter plates:

- First mount the product on the adapter plate.
- Then set the position of the magnetic switch.

The RMS sensors have a larger hysteresis than the MMS sensors. This means that short gripper strokes may not be able to be monitored with the RMS sensors.

#### Positioning the magnetic switch

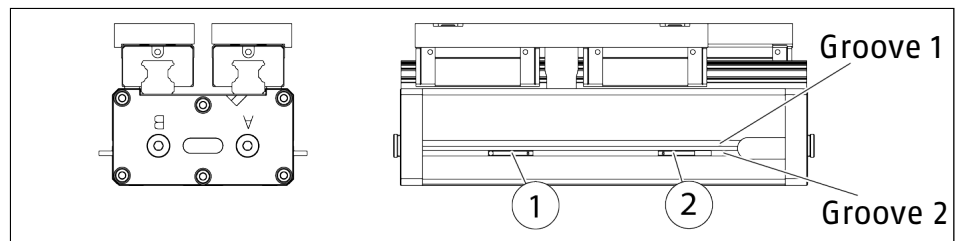

Positioning the magnetic switches

#### Gripper open:

1. Move product to the "gripper open" position.
2. Slide sensor (1) from the side closer to the jaw from the front as far into one of the grooves until the sensor switches.
3. Clamp sensor (1) in this position in the groove with the set-screw.  
Tightening torque: 10 Ncm
4. Bring product into the "gripper open" or "gripper closed" position and test the functioning.

#### Gripper closed:

1. Move product to the "gripper closed" position.
2. Slide sensor (2) from the side closer to the jaw from the front as far into one of the grooves until the sensor switches.
3. Clamp sensor (2) in this position in the groove with the set-screw.  
Tightening torque: 10 Ncm
4. Bring product into the "gripper open" or "gripper closed" position and test the functioning.

**Part gripped (O.D. gripping):**

1. Clamp the part to be gripped.
2. Slide sensor (2) from the side closer to the jaw from the front as far into one of the grooves until the sensor switches.
3. Clamp sensor (2) in this position in the groove with the set-screw.  
Tightening torque: 10 Ncm
4. Bring product into the "gripper open" or "gripper closed" position and test the functioning.

**Part gripped (I.D. gripping):**

1. Clamp the part to be gripped.
2. Slide sensor (2) from the side closer to the jaw from the front as far into one of the grooves until the sensor switches.
3. Clamp sensor (2) in this position in the groove with the set-screw.  
Tightening torque: 10 Ncm
4. Bring product into the "gripper open" or "gripper closed" position and test the functioning.

### 5.4.4 Mount the programmable magnetic switch MMS 22-PI1

#### NOTICE

#### Risk of damage to the sensor during assembly!

- Observe the maximal tightening torque.

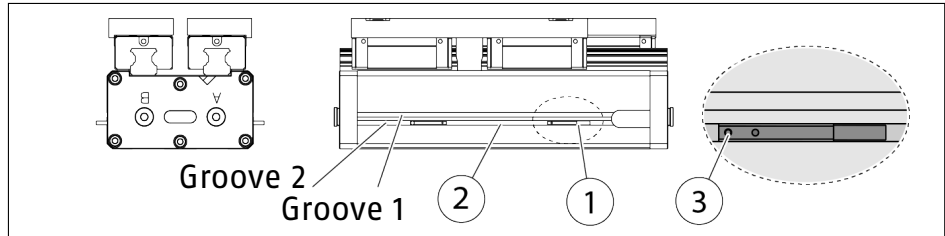

#### NOTE

For size 25, the sensor can only be used in groove 2. For all other sizes, both sensor grooves can be used.

1. Put product in the position in which it is to be set.
2. Hold teaching tool to the sensor 1 (1) until the sensor flashes.
3. Slide sensor 1 (1) into the groove (2), until the sensor 1 flashes rapidly.
  - ⇒ The optimum position is displayed.
4. Secure the sensor 1 (1) using the set-screw (3).  
Tightening torque: 10 Ncm
5. Hold teaching tool to the sensor 1 (1) to confirm the position.
  - ⇒ The sensor 1 (1) has been taught in.
6. Repeat steps for sensor 2.

### 5.4.5 Mounting the Balluff BIP inductive analog position sensor

#### Attachment kit

In order to use the inductive analog position sensor, the gripper must be equipped with a special attachment kit. This attachment kit is available from SCHUNK (for types that can be ordered, see catalog).

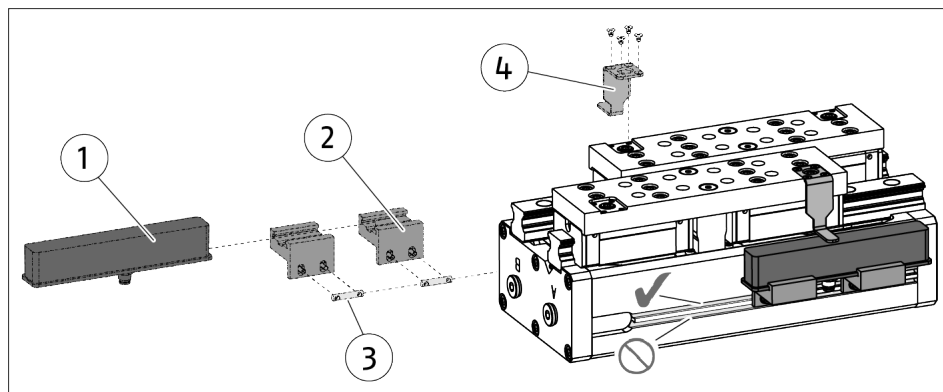

#### Assembly

The mounting material is included in the scope of delivery of the attachment kit.

For sizes **25 and 32**, **2 washers** must be used with each screw for fastening the sensor holders.

1. Fasten the switching cam (4) to a base jaw.
2. Fasten the sensor holder (2) to the gripper using the T-nuts (3).
3. Insert the sensor (1) into the sensor holder (2).
4. Position the sensor (1) in the sensor holder (2) according to the marking on the sensor.
5. Clamp sensor (1) in sensor holder (2).

Information on adjusting the sensor can be found in the operating manual of the sensor (see <http://www.Balluff.com>).

#### Sensor ID number

Sensor designation	Ident number SCHUNK	Ident number Balluff
BIP 048	1561246	BIPO00M
BIP 070	1561247	BIPO00C
BIP 103	1561248	BIPO00E
BIP 133	1561249	BIPO00R

## 6 Troubleshooting

### 6.1 Gripper does not move

Possible cause	Corrective action
Base jaws jammed on the rail, e.g. mounting surface is not sufficiently even.	Check the evenness of the mounting surface. ▶ 5.1 [ 20]. Loosen the mounting screws of the product and actuate the product again.
Pressure drops below minimum.	Check air supply. ▶ 5.3 [ 23]
Compressed air lines switched.	Check compressed air lines.
Proximity switch defective or set incorrect.	Readjust or change sensor.
Unused air connections open.	Close unused air connections.
Flow control valve closed.	If present: Open the flow control valve.
Component part defective.	Replace component or send it to SCHUNK for repair.

### 6.2 Gripper does not execute a complete stroke

Possible cause	Corrective action
Pressure drops below minimum.	Check air supply. ▶ 5.3 [ 23]
Mounting surface is not sufficiently flat.	Check the evenness of the mounting surface. ▶ 5.1 [ 20]
Component part defective.	Send product with a SCHUNK repair order or dismantle product.

### 6.3 Product is opening or closing abruptly

Possible cause	Corrective action
Too little grease in the mechanical guiding areas.	Clean and lubricate product.
Compressed air lines blocked.	Check compressed air lines of damage.
Mounting surface is not sufficiently flat.	Check the evenness of the mounting surface.

## 6.4 Gripping force is dropping

Possible cause	Corrective action
Compressed air can escape.	Check seals, if necessary, disassemble the product and replace seals.
Too much grease in the mechanical movement space.	Clean and lubricate product.
Pressure drops below minimum.	Check air supply. ▶ 3 [17]
Component part defective.	Replace component or send it to SCHUNK for repair.

## 6.5 Product does not achieve the opening and closing times

Possible cause	Corrective action
Compressed air lines are not installed optimally.	If present: Open the flow control couplings on the product to the maximum that the movement of the jaws occurs without bouncing and hitting.
	Check compressed air lines.
	Inner diameters of compressed air lines are of sufficient size in relation to compressed air consumption.
	Keep compressed air lines between the product and directional control valve as short as possible.
	Flow rate of valve is sufficiently large relative to the compressed air consumption.
	If you still cannot achieve the open and close times in the latest catalog, we recommend the use of quick-air-vent-valves directly at the product.

## 7 Maintenance

### 7.1 Notes



#### **⚠ WARNING**

##### **Risk of injury from electric shock due to contact with live parts!**

- Before starting any work: Disconnect the power supply from the mains and secure against accidental switch-on.
- Work may only be performed by appropriately qualified personnel.

##### **Original spare parts**

Use only original spare parts of SCHUNK when replacing spare and wear parts.

#### **7.1.1 Exchanging the rail and base jaws**

The base jaws of the rail system are tuned to one another and cannot be individually replaced. Please order the complete rail system if a unit must be repaired.

#### **7.1.2 Maintenance of module with gripping force maintenance**

You can carry out the maintenance and replace the seals yourself. We recommend having maintenance performed and the seals replaced at SCHUNK as the cover plate is under spring tension.

### 7.2 Maintenance and lubrication intervals

#### **NOTICE**

##### **Material damage due to hardening lubricants!**

Lubricants harden more quickly at temperatures above 60°C, leading to possible product damage.

- Reduce the lubricant intervals accordingly.

Size	Replace all seals	Linear guide lubrication
25	3	0.5
32	2.5	1.5
40	2.5	1.5
50	2	1
63	1.5	1

Tab.: Maintenance intervals in million cycles

### 7.3 Lubricants/Lubrication points (basic lubrication)

During maintenance, treat all greased areas with lubricant. Thinly apply lubricant with a lint-free cloth.

SCHUNK recommends the lubricants listed.

Lubricant point	Lubricant
Metallic sliding surfaces	SCHUNK grease 3
Sliding surfaces within the cylinder	SCHUNK grease 1
Seals and sealing surfaces	SCHUNK grease 1
Linear guide	SCHUNK grease 10

Details regarding SCHUNK lubricant designations are available at [schunk.com/lubricants](https://www.schunk.com/lubricants).

The product contains food-compliant lubricants as standard. Components such as rolling bearings, linear guides, or shock absorbers are not provided with food-compliant lubricants.

**The requirements of standard EN 1672-2:2020 are not fully met.**

In harsh ambient conditions, the base jaws on the linear guide can also be relubricated.

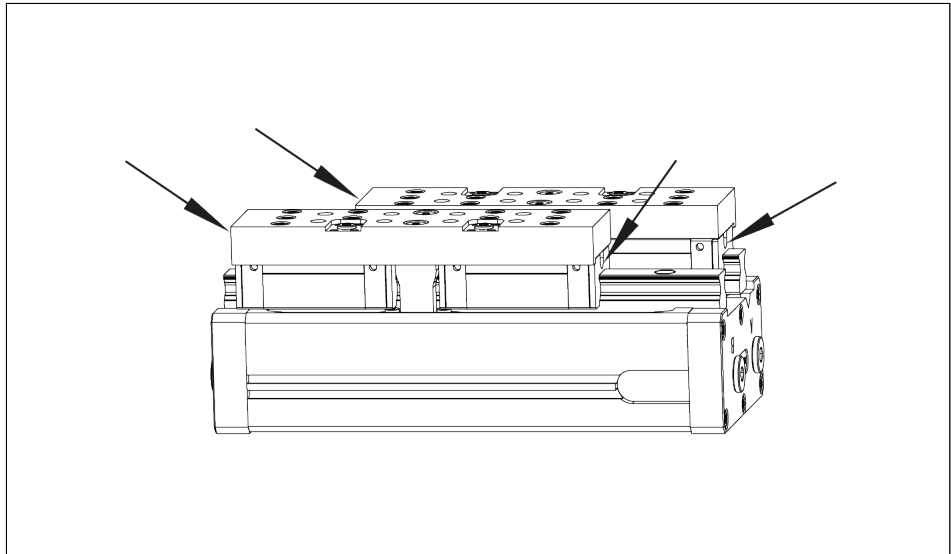

*Lubrication points on the base jaws*

- **Size 25:** The base jaws can be regreased via a hole using a grease gun.
- **Sizes 32 – 63:** The base jaws can be regreased via grease nipples. To do this, insert the grease nipples on the end faces (arrows).
- Always ensure that the same lubricant is used in order to avoid gumming in the lubrication channels. Should a different lubricant be used, a compatibility test will need to be carried out.

Size	Large lubrication hole	Lubrication nipple
25	∅ 2	-
32	M4	A-M4x0.7
40	M4	A-M4x0.7
50	M4	A-M4x0.7
63	M6	B-M6F

**NOTE**

- Change contaminated food-compliant lubricant.
- Observe information in the safety data sheet from the lubricant manufacturer.

## 7.4 Disassembly and assembly

### 7.4.1 Version without gripping force maintenance

Position of the item numbers ▶ 7.6 [ 41]



#### **⚠ WARNING**

##### **Risk of injury due to unexpected movements!**

If the power supply is switched on or residual energy remains in the system, components can move unexpectedly and cause serious injuries.

- Before starting any work on the product: Switch off the power supply and secure against restarting.
- Make sure, that no residual energy remains in the system.

#### **NOTICE**

##### **During removal!**

Do not damage the cylinder running surface when removing the piston.

1. Remove compressed air line.
2. Mark the position of the covers in order to prevent a mix up.
3. Unscrew screws (122) on both sides.
4. Remove cover (11) and centering sleeve (112) on both sides.
5. Remove seals (31).
6. Mark the position of the cylinder pistons.
7. Unscrew screws (120).
8. Pull out cylinder pistons (4), making sure that the cylinder running surface does not become damaged.

### 7.4.2 Variant with gripping force maintenance

Position of the item numbers ▶ 7.6 [ 41]



#### **⚠ WARNING**

##### **Risk of injury due to unexpected movements!**

If the power supply is switched on or residual energy remains in the system, components can move unexpectedly and cause serious injuries.

- Before starting any work on the product: Switch off the power supply and secure against restarting.
- Make sure, that no residual energy remains in the system.



**⚠ WARNING**

**Risk of injury due to spring forces!**

The cover may be ejected due to the high spring forces.

- Dismantle the product carefully.
- 
1. Remove the compressed air lines.
  2. Mark the position of the covers in order to prevent a mix up.
  3. Remove locking screws or air connection at main connection B (on both sides).
  4. Attach a supply air restrictor to the main connection side A and allow the gripper to move slowly to the end position.



**⚠ WARNING**

**Risk of injury due to spring forces!**

The cover may be ejected due to the high spring forces.

- Follow the steps below carefully.
- 
5. Pre-load the spring assembly through the opening of the main connection B using a socket-head screw (see table) until no residual energy is applied to the cover (2x).
  6. Remove compressed air line from main connection side A.
  7. Carefully remove the cover screws (122).
  8. Remove cover (12) and centering sleeve (112) on both sides.

**NOTICE**

**Damage to the gripper if the cylinder running surface is damaged by the spring assemblies.**

- Carefully remove the spring assemblies.
- 
9. Carefully remove the pre-loaded spring assemblies on both sides.
  10. Keep the pre-loaded spring assemblies in a safe place away from dirt and external stresses during maintenance.
  11. Remove seals (31).
  12. Unscrew the screws (121).
  13. Pull out cylinder pistons (4), ensuring that the cylinder running surface does not become damaged.

**Screws during disassembly of the variant with gripping force maintenance**

<b>Size [Stroke length]</b>	<b>Thread size/strength class</b>	<b>Screw length</b>
25	M4/12.9	50
32	M4/12.9	55
40	M4/12.9	60
50	M6/12.9	75
63	M8/12.9	110

## 7.5 Servicing and assembling the product

### Maintenance

- Clean all parts thoroughly and check for damage and wear.
- Treat all greased areas with lubricant.
  - ▶ 7.3 [ 35]
- Oil or grease bare external steel parts.
- Replace all seals.
  - The seals are in the enclosed sealing kit. ▶ 1.4 [ 8]

### Assembly

Position of the item numbers ▶ 7.6 [ 41]

Assembly takes place in the opposite order to disassembly.

Observe the following:

- Observe the installation position of the cylinder pistons (item 4) and the covers (11).
- Make sure that the seal and the cylinder running surfaces do not become damaged when pushing in the cylinder piston.
- Make sure that the cylinder piston is positioned in the centering collar of the gear rack (5/6/7) when tightening the screw (120/121).
- Unless otherwise specified, secure all screws and nuts with Loctite no. 243 and tighten with the appropriate tightening torque.▶ 7.5.1 [ 40]

### 7.5.1 Torque for screws [Nm]

Position of the item numbers ▶ 7.6 [ 41]

Size	Piston Item 120	Cover Item 122	Guide rails Item 124	Driver Item 125	Bridge Item 126	Cover plate Item 129
25	5.9	1.27	1.27	1.27	1.27	1.27
32	14.7	2.5	5.9	3.0	3.0	1.27
40	30	3.5	5.9	5.9	5.9	1.27
50	71.0	10.1	5.9	10.1	5.9	1.27
63	120	24.6	10.1	10.1	10.1	1.27

Tab.: Torques for screws [Nm]

## 7.6 Assembly drawing

The following figures are example images. They serve for illustration and assignment of the spare parts. Variations are possible depending on size and variant.

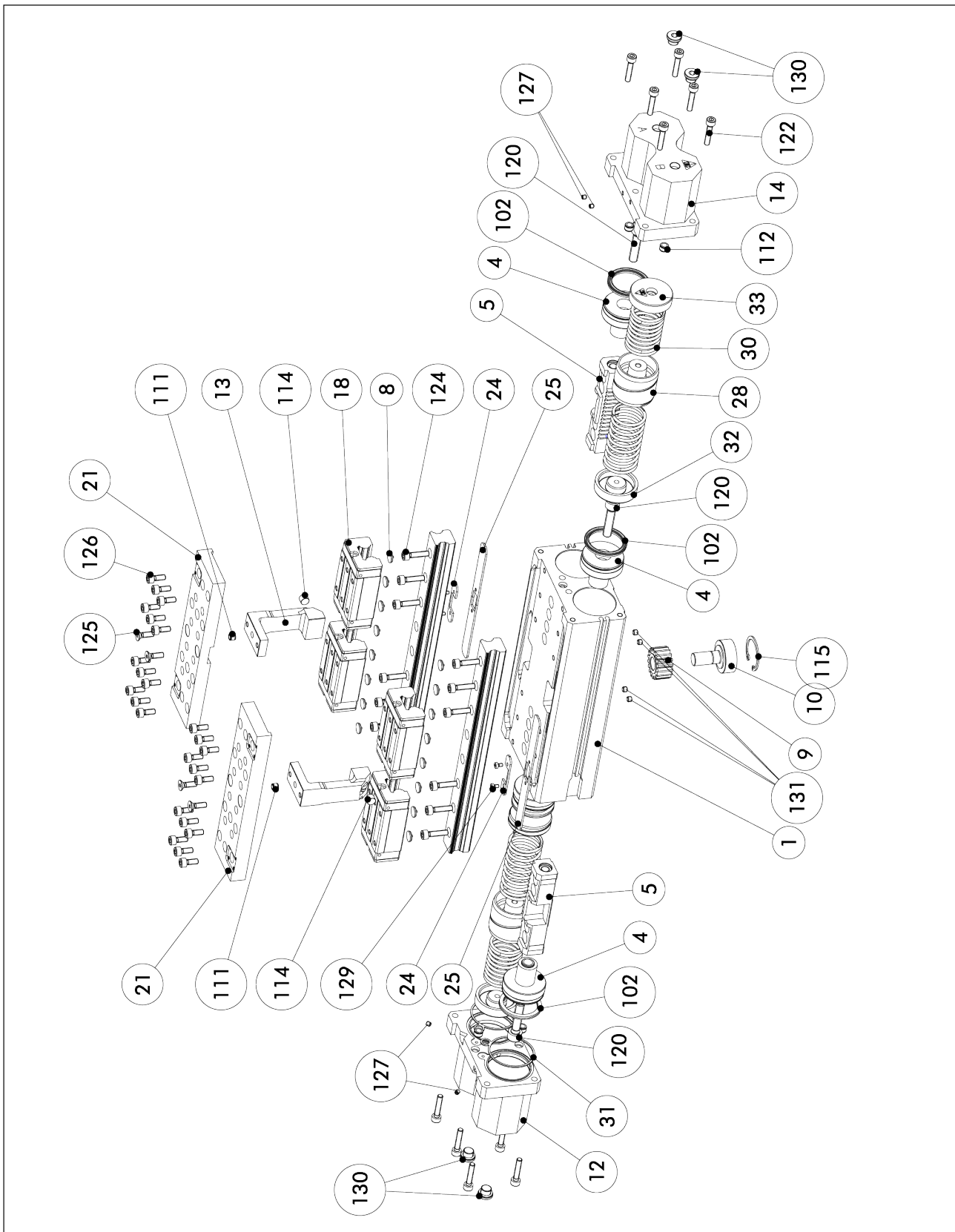

## 8 Translation of the original declaration of incorporation

in terms of the Directive 2006/42/EG, Annex II, Part 1 Section B.

Manufacturer/  
Distributor SCHUNK SE & Co. KG  
Spanntechnik | Greiftechnik | Automatisierungstechnik  
Bahnhofstr. 106 – 134  
D-74348 Lauffen/Neckar

We hereby declare that the partly completed machine described below

Product designation: 2-finger parallel gripper / PHL /pneumatic  
ID number 1462512, 1462517, 1462524, 1462546, 1462548, 1462551, 1462553,  
1462558, 1462560, 1462562, 1462563, 1462565, 1462569 1462581,  
1462587, 1462589, 1462590, 1462591, 1462597, 1462599, 1462600,  
1462601, 1462605, 1462608, 1462614, 1462616, 1462620, 1462621,  
1462622, 1462623

meets the following basic occupational health and safety of the Machinery Directive 2006/42/EC:  
No. 1.1.1, No. 1.1.2, No. 1.1.3, No. 1.1.5, No. 1.3.2, No. 1.5.3, No. 1.5.4, No. 1.5.6, No. 1.5.8, No.  
1.5.10, No. 1.5.11, No. 1.5.13

The partly completed machinery may not be put into operation until it has been confirmed that the machine into which the partly completed machinery is to be installed complies with the provisions of the Machinery Directive (2006/42/EC). The declaration shall be rendered invalid if modifications are made to the product.

Applied harmonized standards, especially:

EN ISO 12100:2010 Safety of machinery – General principles for design –  
Risk assessment and risk reduction

The special technical documentation according to Annex VII, Part B, belonging to the partly completed machine, has been created.

Person authorized to compile the technical documentation:  
Stefanie Walter, Address: see manufacturer's address

*Signature: see original declaration*

Dr.-Ing. Manuel Baumeister,  
Head of Systems Engineering,  
Technology & Innovation

Lauffen/Neckar, August 2025

## 9 Information on the RoHS Directive, REACH Regulation and Substances of Very High Concern (SVHC)

### RoHS Directive

SCHUNK products are classified as "large-scale stationary installations" or as "large-scale stationary industrial tools" within the meaning of Directive 2011/65/EU and its extension 2015/863/EU "on the restriction of the use of certain hazardous substances in electrical and electronic equipment (RoHS)", or fulfill their intended function only as part of one. Therefore products from SCHUNK do not fall within the scope of the directive at this time.

### REACH Regulation

Products from SCHUNK fully comply with the regulations of Regulation (EC) No. 1907/2006 "concerning the Registration, Evaluation, Authorization and Restriction of Chemicals (REACH)" and its amendment 2022/477. SCHUNK attaches great importance to completely avoiding chemicals of concern to humans and the environment wherever possible.

Only in rare exceptional cases do SCHUNK products contain SVHC substances on the candidate list with a mass content above 0.1%. In accordance with Article. 33 (1) of Regulation (EC) No. 1907/2006, SCHUNK complies with its duty to "communicate information on substances in articles" and lists the components concerned and the substances used in an overview that can be viewed at [schunk.com/SVHC](https://schunk.com/SVHC).

*Signature: see original declaration*

Dr.-Ing. Manuel Baumeister,  
Head of Systems Engineering,  
Technology & Innovation

Lauffen/Neckar, August 2025

## 10 UKCA declaration of incorporation

in accordance with the Supply of Machinery (Safety) Regulations 2008.

Manufacturer/  
Distributor                      SCHUNK Intec Limited  
                                            Clamping and gripping technology  
                                            3 Drakes Mews, Crownhill  
                                            MK8 0ER Milton Keynes

We hereby declare that on the date of the declaration the following partly completed machine complied with all basic safety and health regulations found in the "Supply of Machinery (Safety) Regulations 2008".

The declaration shall be rendered invalid if modifications are made to the product.

Product designation:        2-finger parallel gripper / PHL / pneumatic  
ID number                      1462512, 1462517, 1462524, 1462546, 1462548, 1462551, 1462553,  
                                            1462558, 1462560, 1462562, 1462563, 1462565, 1462569 1462581,  
                                            1462587, 1462589, 1462590, 1462591, 1462597, 1462599, 1462600,  
                                            1462601, 1462605, 1462608, 1462614, 1462616, 1462620, 1462621,  
                                            1462622, 1462623

The partly completed machine may not be put into operation until it has been confirmed that the machine into which the partly completed machine is to be installed complies with the provisions of the "Supply of Machinery (Safety) Regulations 2008".

Applied harmonized standards, especially:

EN ISO 12100:2010              Safety of machinery – General principles for design –  
                                            Risk assessment and risk reduction

The special technical documentation according to Annex VII, Part B, belonging to the partly completed machine, has been created.

Person authorized to compile the technical documentation:  
Marcel Machado, address: refer to manufacturer's address



Dr.-Ing. Manuel Baumeister,  
Head of Systems Engineering,  
Technology & Innovation

Lauffen/Neckar, August 2025

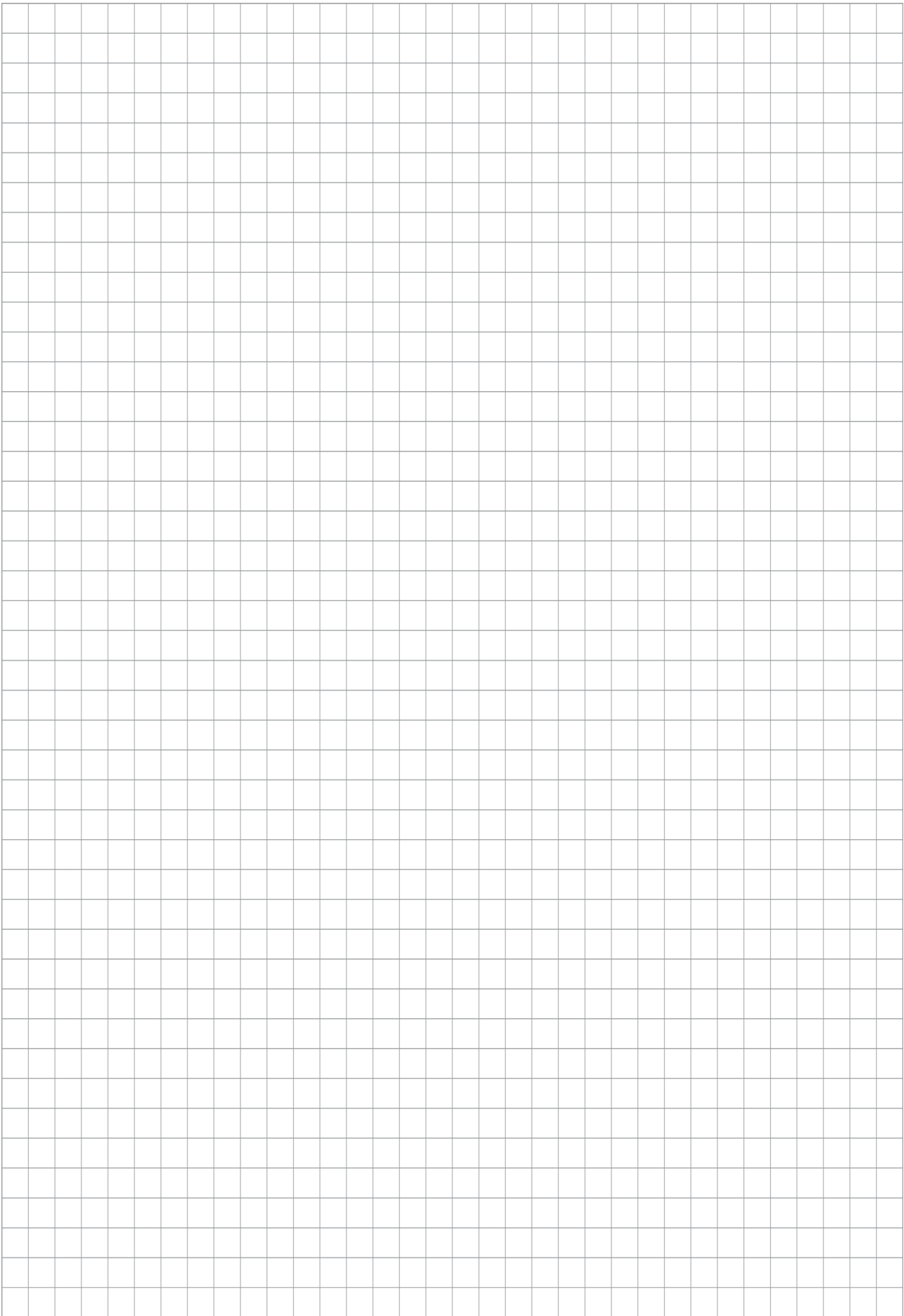

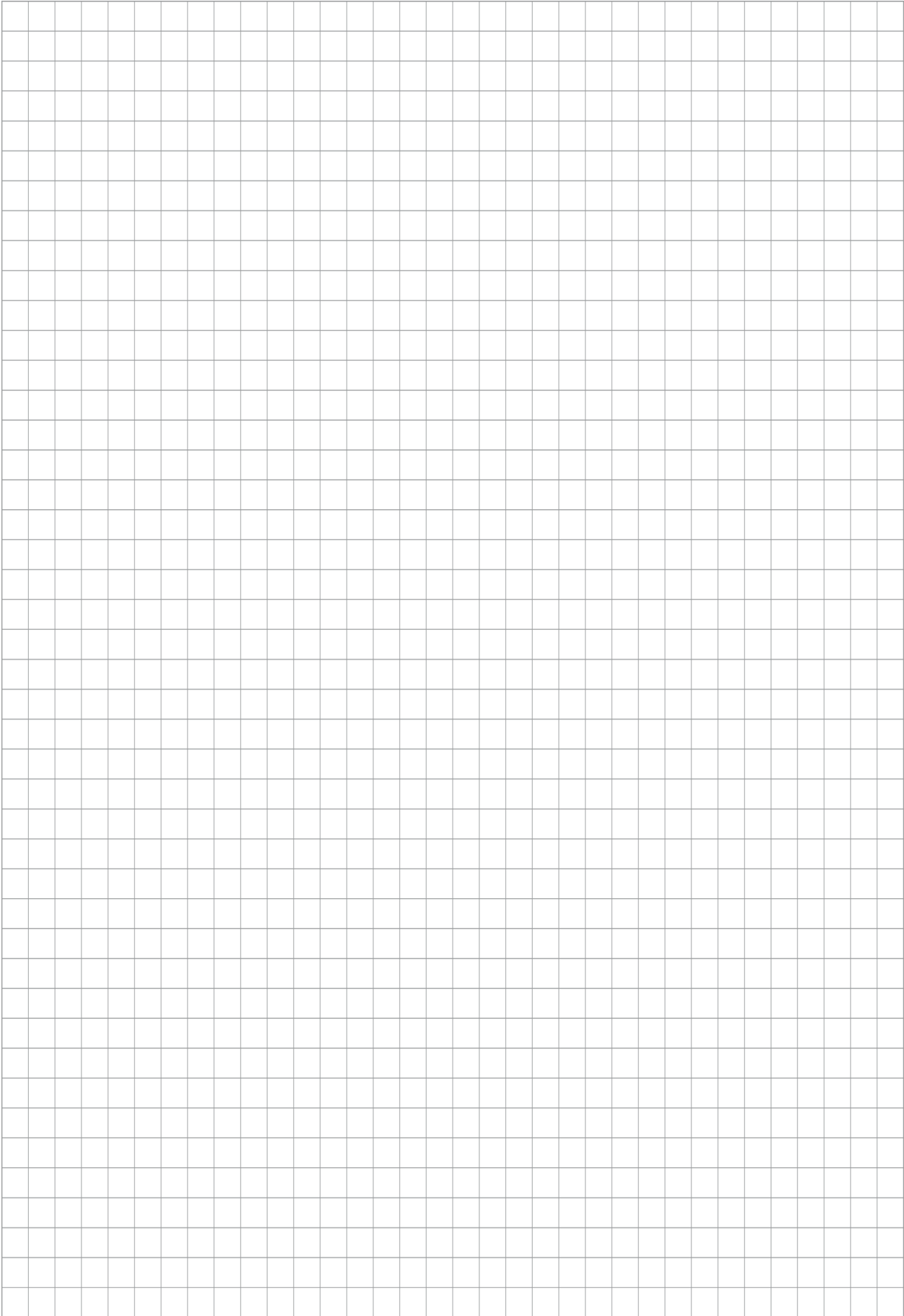





**SCHUNK SE & Co. KG**  
Spanntechnik | Greiftechnik | Automatisierungstechnik

Bahnhofstr. 106 – 134  
D-74348 Lauffen/Neckar  
Tel. +49-7133-103-0  
info@de.schunk.com  
schunk.com

Folgen Sie uns | *Follow us*



Wir drucken nachhaltig | *We print sustainable*