

Double-sided magnetic modules

# MFRS-DM

Installation, use and maintenance manual.

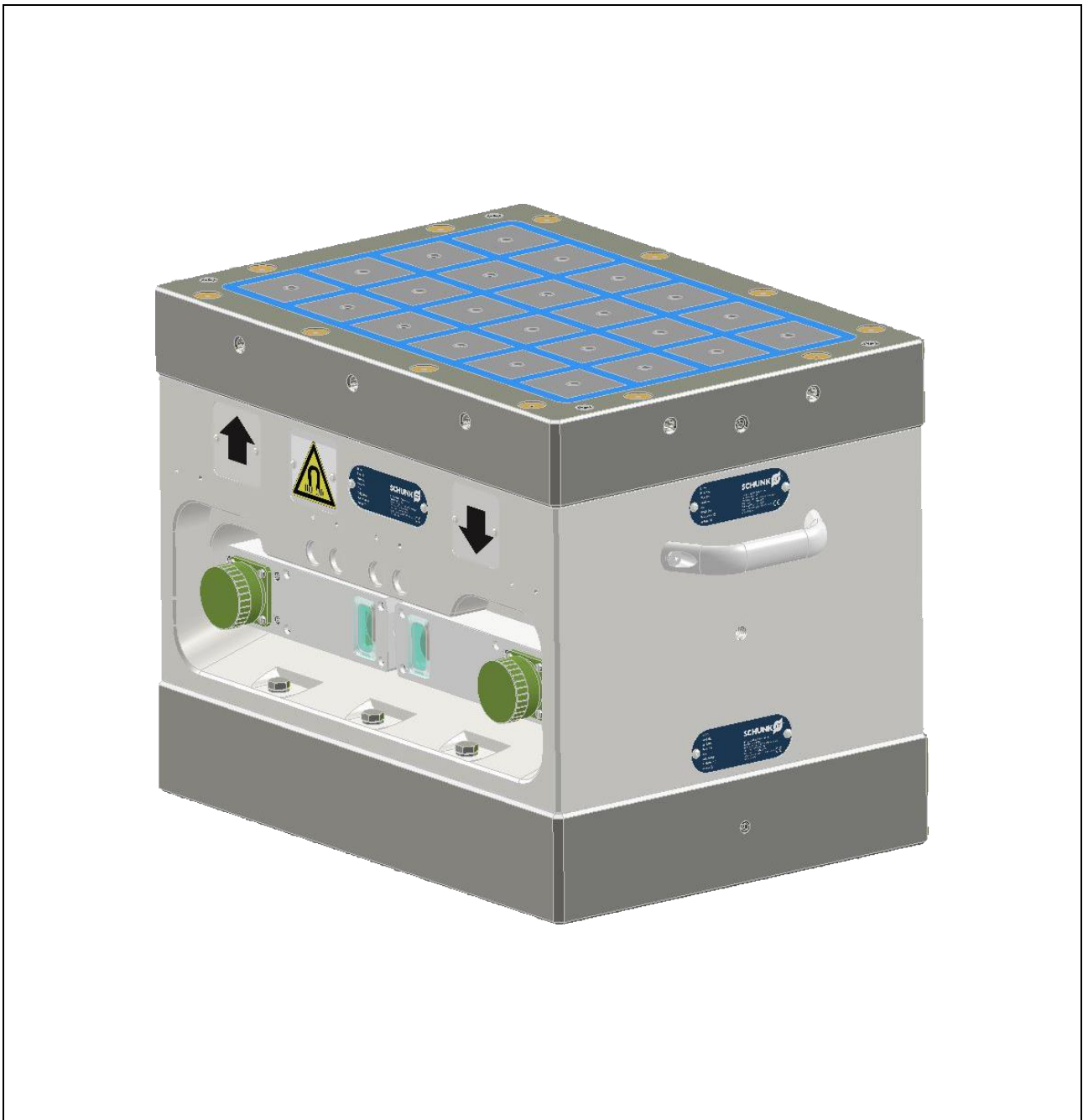

© This manual remains the copyrighted property of SCHUNK GmbH & Co. KG. It is solely supplied to our customers and users of our products and is an integral part of the product. This documentation may not be duplicated or made accessible to third parties, in particular competing companies, without our prior permission.

**Document:** 5053860  
**Edition:** 1.0  
**Date:** 08/05/2023

In order to improve product quality and performance, we reserve the right to make technical changes at any time without notice. The images of the products contained in the manual are purely indicative and may therefore not be perfectly representative of the packaging and characteristics of the product, differing in colour, size or content. For any doubts or questions, please contact our Customer Service.

Dear customer,  
congratulation on choosing a SCHUNK product. By choosing SCHUNK, you have opted for the highest precision, top quality and best service.  
You are going to increase the process reliability of your production and achieve best machining results – to the customer's complete satisfaction.  
SCHUNK products are inspiring.  
Our detailed assembly and operation manual will support you.  
Do you have further questions? You may contact us at any time – even after purchase.  
Kindest Regards.

**H.-D. SCHUNK GmbH & Co. Spanntechnik KG**

Lothringer Str. 23  
88512 Mengen  
Deutschland  
Tel. +49-7572-7614-0  
Fax +49-7572-7614-1099  
info@de.schunk.com  
www.schunk.com



---

## Table of contents

|   |           |
|---|-----------|
| <b>1. Warnings</b> .....                      | <b>4</b>  |
| 1.1 Terminology .....                         | 4         |
| 1.2 Symbols .....                             | 4         |
| <b>2. Basic safety notes</b> .....            | <b>5</b>  |
| 2.1 Intended use .....                        | 5         |
| 2.2 Safe use of the product .....             | 5         |
| 2.3 Personnel qualification .....             | 5         |
| 2.4 Using personal protective equipment ..... | 5         |
| 2.5 Notes on particular risks .....           | 6         |
| <b>3. Warranty</b> .....                      | <b>7</b>  |
| <b>4. Delivery content</b> .....              | <b>8</b>  |
| <b>5. Technical data</b> .....                | <b>9</b>  |
| 5.1 Identification plate.....                 | 10        |
| <b>6. Description</b> .....                   | <b>11</b> |
| 6.1 Mechanical devices .....                  | 13        |
| 6.2 Pole extensions .....                     | 13        |
| <b>7. Installation and operation</b> .....    | <b>16</b> |
| <b>8. Troubleshooting</b> .....               | <b>21</b> |
| <b>9. Servicing and maintenance</b> .....     | <b>22</b> |
| <b>10. Transportation and storage</b> .....   | <b>23</b> |
| <b>11. Disposal</b> .....                     | <b>24</b> |
| <b>12. Spare parts</b> .....                  | <b>24</b> |

## 1. Warnings

The manual contains important information regarding the assembly, start-up, use and maintenance of the product. Terms and symbols used in the manual to highlight dangerous situations are listed below.

### 1.1 Terminology

|                  |   |
|------------------|---|
| <b>DANGER</b>    | Dangers for people. High probability of irreversible injury or death. |
| <b>WARNING</b>   | Dangers for people. Low probability of irreversible injury or death.  |
| <b>CAUTION</b>   | Dangers for people. Possibility of minor injuries.                    |
| <b>ATTENTION</b> | Information about avoiding material damage.                           |
| <b>NOTE</b>      | Useful information and advice.  |

### 1.2 Symbols



Generic warning sign



Electricity warning sign



Magnetic field warning sign



Suspended loads warning sign



Generic mandatory sign



Information sign

## 2. Basic safety notes

### 2.1 Intended use

The product must only be used in a context that complies with its defined application parameters. For correct use, it is essential to observe the technical data, installation and operating notes contained in the manual and respect the scheduled maintenance intervals.

This product must not be placed in service until the the combined "product + user machine" system satisfies the requirements of the Machinery Directive.

### 2.2 Safe use of the product

To meet the minimum safety requirements, use the product:

- according to its intended use
- within the application parameters defined by the project
- in clean working environments
- at temperature corresponding to specification
- respecting the installation and maintenance procedures
- avoiding work methods that could be harmful
- wearing protective devices as required by the Machinery Directive.

### 2.3 Personnel qualification

Assembly, start-up, maintenance and repairs of the product must only be carried out by qualified personnel. Every person assigned by the operator to carry out work on the product must have read and understood this manual in its entirety, in particular the chapter "Basic safety notes".



### 2.4 Using personal protective equipment

When using this product, observe the relevant industrial safety regulations and use the personal protective equipment (PPE) required :

- use protective gloves, safety shoes and safety goggles
- observe safe distances
- comply with the minimum safety requirements for the use of the equipment.

|               |  |
|---------------|--|
| <b>DANGER</b> | <p><b><i>Danger due to a magnetic field.</i></b></p> <p><i>The persons described below must absolutely maintain a safety distance of more than 2 m from the magnetic system:</i></p> <ul style="list-style-type: none"> <li>• <i>persons with pacemakers.</i></li> <li>• <i>persons with metal or electronic prostheses.</i></li> <li>• <i>persons with insulin pumps.</i></li> <li>• <i>persons with muscular stimulation systems.</i></li> <li>• <i>pregnant women.</i></li> </ul> |
|---------------|--|



|   |   |
|---|---|
| <b>CAUTION</b>  |   |
|  | <p><i>For all workers not suffering from particular pathologies, the magnetic field generated by the product is not such as to create health problems in the short term. However, it is recommended to always remain at a safe distance from the magnetized product.</i></p>  |
| <b>DANGER</b>   |   |
|  | <p><b><i>Danger from electric shock.</i></b><br/><i>The electro-permanent chucks are electrically powered systems, often in contact with emulsified water or different types of liquids. It is therefore strictly prohibited to touch the magnetic chuck or any part connected to it (circular connector, cables, ecc.) when being magnetized and demagnetized.</i></p> |

## 2.5 Notes on particular risks

- Turn off the power before carrying out installation or maintenance work.
- Make sure there is no residual energy left in the system.
- Carry out extension, modification or maintenance work outside the danger zone.
- Secure the product against accidental use before each job.

### 3. Warranty

The product is guaranteed for any lack of conformity existing at the time of delivery, which occurs within *12 months* from the delivery date.

Without prejudice to the content and duration described above, the legal guarantee is excluded in the following cases:

- defects or malfunctions of the product caused by atmospheric and natural events
- accidental damage or breakage
- improper or negligent use of the product
- failure to observe the instructions and indications for installation and operation
- incorrect maintenance
- maintenance carried out with non-original spare parts.

*Parts in contact with the piece and parts subject to wear are excluded from the guarantee.*

The request for repair or replacement of the product under warranty must be preceded by a detailed written report of the defects found, within 10 days of their discovery.

The Service personnel will carry out an intervention to check if the product has a manufacturing defect. If found, it will carry out the repair or replacement of the product within a reasonable period of the request and without any charge to the customer. In the event that the Service staff ascertains that the malfunction does not depend on a manufacturing defect, the customer may be asked to reimburse the cost, previously indicated, incurred for the verification.

## 4. Delivery content

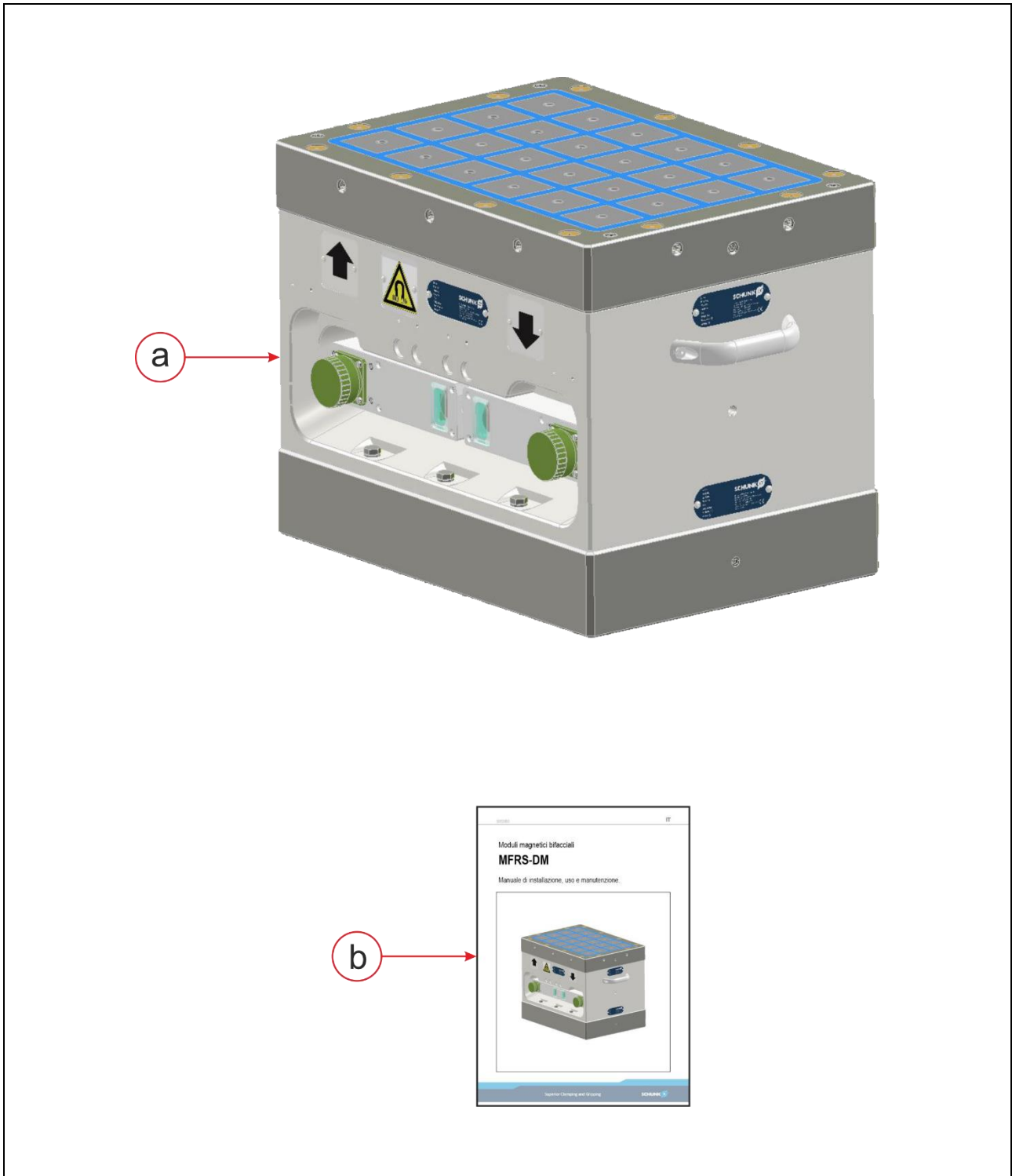

- a. Double-sided magnetic module
- b. Installation, use and maintenance manual.

## 5. Technical data

| Model   | Dimensions |        |       |        | Poles<br>[No.] | Weight<br>[Kg] |
|---------|------------|--------|-------|--------|----------------|----------------|
|         | Length *   | Length | Width | Height |                |                |
| 1546522 | 505        | 430    | 315   | 346    | 24             | 225            |
| 1546528 | 705        | 630    | 315   | 346    | 32             | 370            |
| 1546542 | 890        | 815    | 315   | 346    | 40             | 450            |
| 1546544 | 1105       | 1030   | 315   | 346    | 48             | 600            |

\* Length including the overall dimensions of the handles.

## 5.1 Identification plate

Three plates are affixed to the product to identify :

- technical data of the product (front plate) (targhetta frontale)
- technical data of the upper magnetic chuck (upper side plate)
- technical data of the lower magnetic chuck (lower side plate)



|                   |                     |
|-------------------|---------------------|
| <b>Id. No.</b>    | Identification code |
| <b>Prod. No.</b>  | Production code     |
| <b>Work No.</b>   | Production number   |
| <b>Serial No.</b> | Serial number       |
| <b>Year</b>       | Year of production  |
| <b>Weight</b>     | Weight              |
| <b>Resistance</b> | Ohmic resistance    |
| <b>Voltage</b>    | Voltage             |

|             |  |
|-------------|--|
| <b>NOTE</b> | <p><i>The plates affixed to the product must never be removed.<br/>For any contacts with the SCHUNK Customer Assistance Service, please specify to the operator the model and serial number indicated on the product identification plate.</i></p> |
|             |  |

## 6. Description

The product is designed for gripping almost all ferromagnetic materials. The obtainable anchoring force depends on the magnetic resistance of the material and therefore on its chemical composition.

By exploiting the magnetic force, the workpiece on milling machines, machining centres, etc. can be firmly anchored to the chuck, allowing the machine tool to perform high-speed and multi-sided machining. The ease of clamping and releasing of the workpiece also allows you to increase the productivity of machine tools by avoiding blockages and equipment changes. The electro-permanent feature of the chuck also allows you to operate in complete safety in the event of a sudden power failure: in fact, the system requires current only during the cycles of magnetization and demagnetization of the chuck and therefore, a sudden power failure can cause the machine to stop tool, while the magnetic chuck would remain magnetized.

The table below shows the reduction percentages for some of the more typical materials.

| <b>MATERIALS</b>                                      | <b>EFFICIENCY</b> |
|---|-------------------|
| <b>Conventional steel</b>                             | 100%              |
| <b>Ferromagnetic raw steel</b>                        | 90%               |
| <b>Tool steel, case hardened steel, profile steel</b> | 70-80%            |
| <b>Magnetic stainless steel</b>                       | 65%               |
| <b>Cast-iron</b>                                      | 50%               |

Some materials cannot be used with this type of product. The most common are :

- aluminium and its alloys
- bronze
- brass
- non-magnetic cast-iron
- some stainless steels (austenitic types)
- alloys of materials with the presence of residual magnetism in the piece.

### *Thermal treatments of materials*

Some heat treatments reduce the magnetic attraction property. Therefore, particular attention must be paid to those materials that have undergone one of the following treatments:

- hardening in all possible variants
- tempering
- cementing
- nitriding

To take the greatest advantage of the magnetic force, pay attention to:

- positioning the piece onto the magnetic chuck;
- the contact surface between the piece to be clamped and the magnetic chuck;
- the air gap value (space between chuck and piece to be attracted).

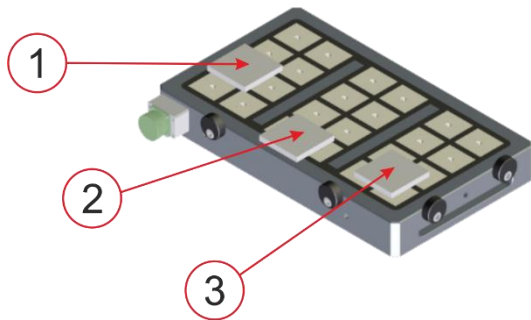

#### Example A

1. The piece rests only on one pole: the magnetic force is very low.
2. The piece rests on two poles: the magnetic force is low.
3. The piece rests on two rows of adjacent poles and therefore best exploits the magnetic force.

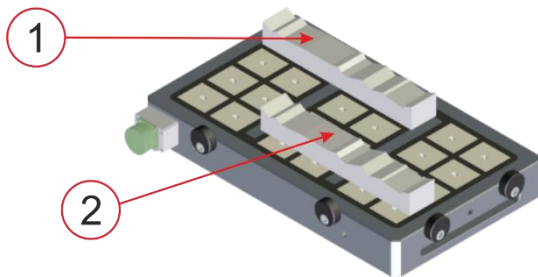

#### Example B

1. The piece covers a single row of poles, the magnetic force is reduced.
2. Better positioning is obtained when the piece rests on at least four adjacent poles. In this case, the hinge effect of magnetic force is exploited.

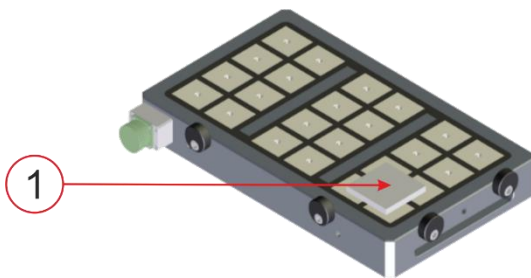

#### Example C

1. Ideal positioning is obtained when the piece fully covers the surface of at least four adjacent poles. In this case, the magnetic attraction force and its hinge effect are best exploited.

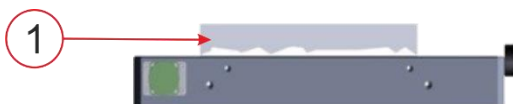

#### Example D

1. The piece has a limited surface and only rests on a few strongly limited magnetic attraction force points.

## 6.1 Mechanical devices

Striker washers are supplied for some magnetic chucks as safety elements with the task of “helping” the chuck to hold the piece against possible sliding on the chuck due to the machining it undergoes.

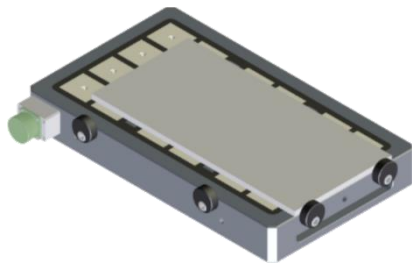

Single support piece

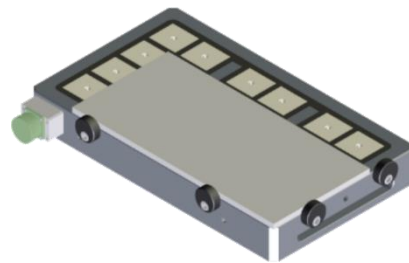

Double support piece

## 6.2 Pole extensions

Fixed or mobile type pole extensions are mechanical devices that are supplied on request.

### Fixed extensions

Fixed extensions are used for special work processes. They enable to perform contouring of the piece, of the through holes in the piece, processing on five square sides without damaging the surface of the magnetic chuck. Furthermore, if shaped properly, they can obtain a negative imprint of the piece to be processed, thus enhancing the magnetic grip.

The correct use of the extensions depends on their correct positioning. Each extension must be mounted on a single pole using the supplied screw. The extension must not rest on two poles, as it would close the magnetic circuit without transmitting it to the piece. It is recommended to mount a sufficient number of fixed extensions to cover the entire surface of the workpiece. Make sure to distribute an equal number of pole extensions on the positive and negative poles of the magnetic chuck to achieve ideal magnetic balancing.

### ATTENTION



*Fixed extensions are supplied with a decimal tolerance in height and flatness. It is therefore necessary, after mounting on the magnetic surface, to reset the support surface by flattening.*

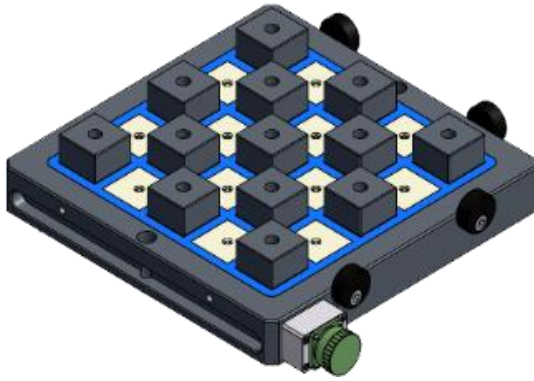

Incorrect distribution : evident pole unbalance



Correct distribution

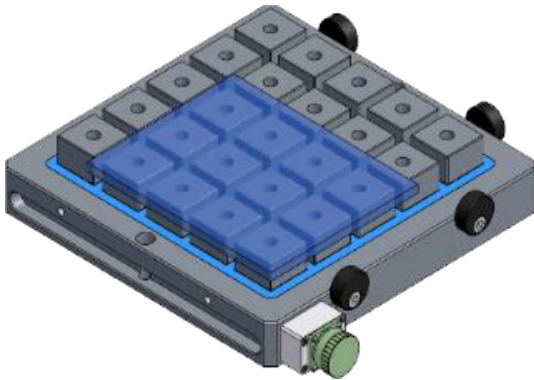

Piece lifted up: to contour, drill, square, make through grooves

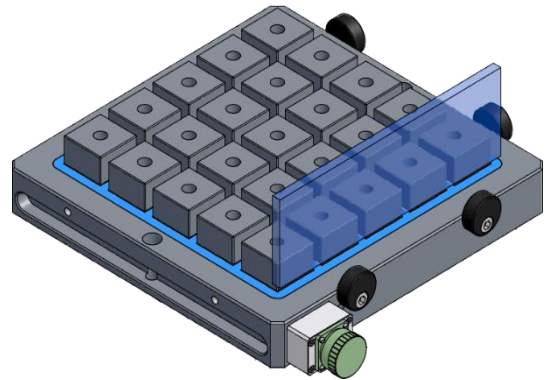

Processing with extension side clamping

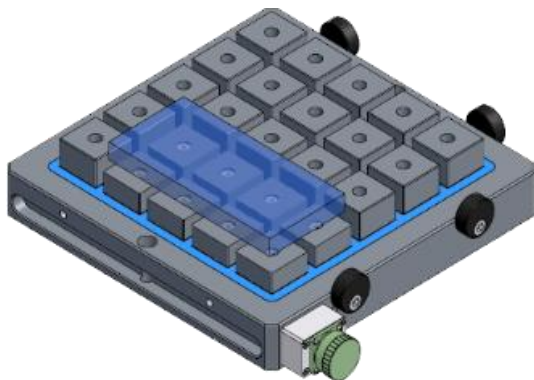

Processing with magnetic striker shoulder

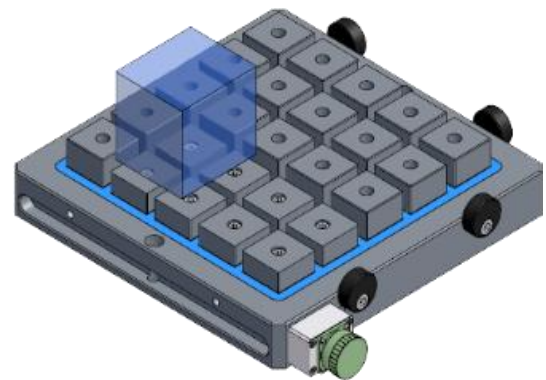

Processing with magnetic striker shoulder

### Mobile extensions

These extensions are used to level warped plates or to process shaped plates. Their flexible self-levelling system allows them to adapt themselves to the curvature of the plate to be processed.

| NOTE  |   |
|---|---|
|  | <p><i>The use of mobile expansions always requires the presence of 3 fixed extensions (indicated in the following image with small circles) which serve as a fixed reference chuck.</i></p> |

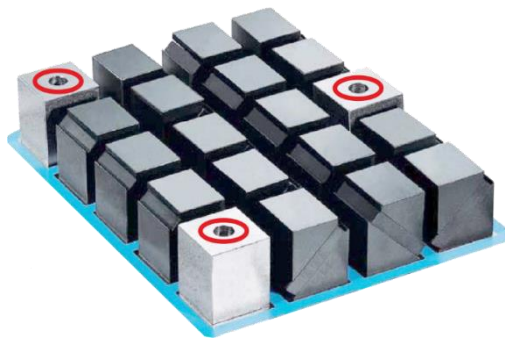

These extensions make it possible to achieve centesimal planarity in just two operations:

- levelling the upper surface of the deformed plate
- turning the plate over and levelling the other side.

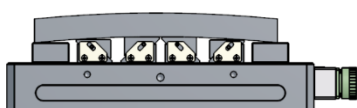

First processing of the deformed plate

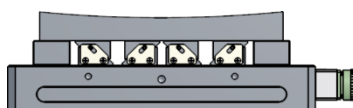

Second processing of the deformed plate



Final result

| NOTE  |  |
|---|--|
|  | <p><i>Using pole extensions can decrease the magnetic chuck force. For further information, contact technical support, giving them the data of the magnetic chuck and the type of process you want to carry out.</i></p> |

## 7. Installation and operation

- Check the packaging before accepting the product.
  - Take out the product and check that it is free from damage caused by transport.
  - Compare the product with the specifications given in the order.
  - Clean any rustproof oil from the magnetic chuck.
  - Check the integrity of the connection cables.
- 
- The product is designed to be placed on flat surfaces, preferably without imperfections.
  - Through 4 fixing points **1** arranged on the upper magnetic chuck, it is possible to insert eyebolts for hooking to a lifting system.

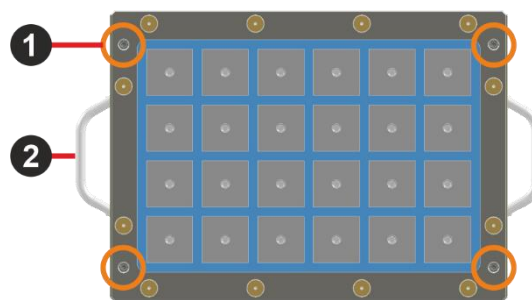

- Clean the flat surface on which the magnetic module will be placed.
- Verify that the magnetic module is demagnetized.
- Lay the magnetic module on the flat table and adjust its positioning using the handles **2** and using the rollers **3** located on the bottom of the product.

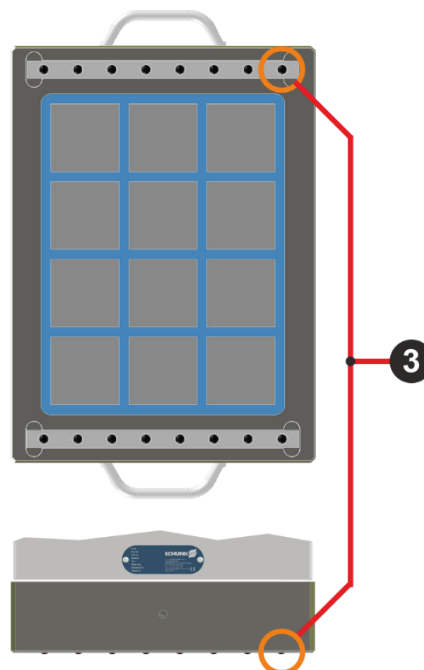

- For tables with slots, to avoid jamming of the magnetic module during movement, take advantage of the oblique movement.

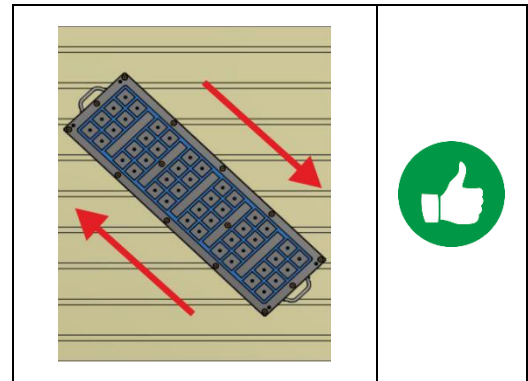
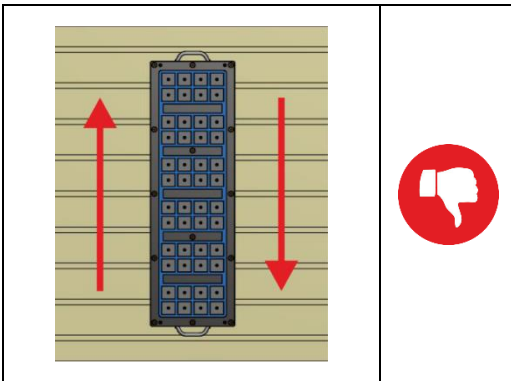

### WARNING



#### **Danger due to suspended loads.**

If moving the magnetic module requires the use of lifting equipment, cranes etc., please keep the respective safe distances.

### WARNING



#### **Positioning of the magnetic module.**

The magnetic module cannot be used upside down. The lower chuck, which comes into contact with the flat table, is the one equipped with the movement rollers. Follow the procedure indicated in this manual.

- After positioning the magnetic module, remove the protective cap from the connector of the lower magnetic chuck ④ and connect the discharge cable to make the connection with the control unit.

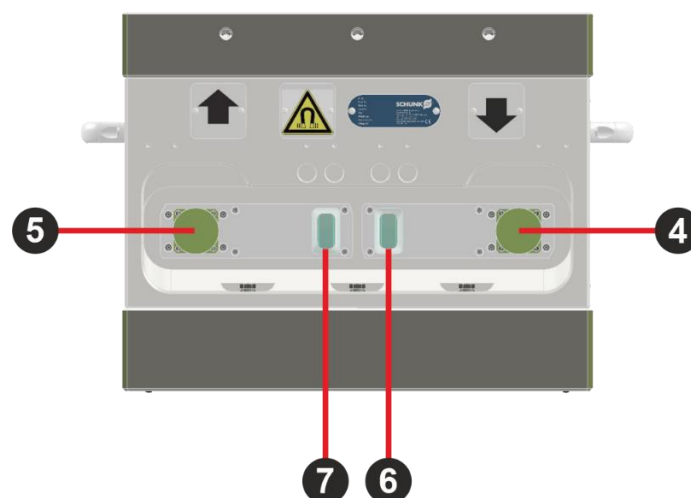

**CAUTION****Problems due to incorrect connection.**

Connect the discharge cable to the magnetic chuck by turning the connector ring nut clockwise as far as it will go. Incorrect connections can generate problems during the magnetization or demagnetization phases.

**WARNING****Danger from electric shock.**

Touching live parts can cause death by electric shock. The control unit may be opened for the connections to the mains only by an electrician. Removing protective devices is reserved exclusively to SCHUNK. Always disconnect the product from the power supply before any intervention.

- Carry out the magnetization maneuver of the lower chuck (ref. Control unit manual).
- Verify that the magnetic status indicator of the lower chuck ⑥ is positioned on green.

**WARNING****Risk of injury.**

Make sure that the magnetic chuck is perfectly anchored to the table, adopting the necessary safety precautions. Faults or malfunctions of the control unit could in fact generate false indications on the state of the magnetic system.

- Remove the discharge cable and replace the protective cap on the connector
- Repeat the positioning and anchoring maneuvers for the other magnetic modules, if present.
- Position and fix any extensions on the upper magnetic chuck
- Position the workpiece on the upper magnetic chuck

**WARNING****Danger due to suspended loads.**

If moving the load requires the use of lifting equipment, cranes etc., please keep the respective safe distances.

- Clean the connection elements and contact surfaces and remove possible causes of problems (water, chips, dirt,...).
- Remove the protective cap from the upper magnetic chuck connector ⑤ and connect the discharge cable to connect with the control unit.

**CAUTION****Problems due to incorrect connection.**

Connect the discharge cable to the magnetic chuck by turning the connector ring nut clockwise as far as it will go. Incorrect connections can generate problems during the magnetization or demagnetization phases.

**WARNING****Danger from electric shock.**

Touching live parts can cause death by electric shock. The control unit may be opened for the connections to the mains only by an electrician. Removing protective devices is reserved exclusively to SCHUNK. Always disconnect the product from the power supply before any intervention.

- Carry out the magnetization maneuver of the upper chuck (ref. Control unit manual).
- Verify that the magnetic status indicator of the upper chuck ⑦ is positioned on green.

**WARNING****Risk of injury.**

Make sure that the magnetic chuck is perfectly anchored to the table, adopting the necessary safety precautions. Faults or malfunctions of the control unit could in fact generate false indications on the state of the magnetic system.

- Remove the discharge cable and replace the protective cap on the connector.

**ATTENTION****Damage to the product for use with the discharge cable connected.**

During machining, remove the discharge cable and place the protective cap on the connector. This operation avoids damaging the magnetic module and the connected control unit.

- Proceed with machining the workpiece.
- After machining, clean the connection elements and contact surfaces and remove possible causes of problems (water, chips, dirt,...).
- Remove the protective cap from the upper magnetic chuck connector ⑤ and connect the discharge cable to connect with the control unit.

**CAUTION****Problems due to incorrect connection.**

Connect the discharge cable to the magnetic chuck by turning the connector ring nut clockwise as far as it will go. Incorrect connections can generate problems during the magnetization or demagnetization phases.

- Carry out the demagnetization maneuver of the upper chuck (ref. Control unit manual).
- Verify that the magnetic status indicator of the upper chuck **7** is positioned on red.

**WARNING****Risk of injury.**

Always make sure that the piece is not anchored to the magnetic chuck, taking the necessary safety precautions. Faults or malfunctions of the control unit could in fact generate false indications on the state of the magnetic system.

- If no further machining is desired, remove the discharge cable and replace the protective cap on the connector.

**WARNING****Danger due to suspended loads.**

If moving the load requires the use of lifting equipment, cranes etc., please keep the respective safe distances.

- Remove the workpiece from the magnetic chuck.

**ATTENTION****Product damage due to overheating.**

The magnetic chucks are designed to withstand a maximum temperature of 80°C. Too close magnetization/demagnetization maneuvers or machining of very hot workpieces can cause the internal temperature of the chucks to rise rapidly and cause the resin to rise or blacken. Avoid such situations to prevent damage to the product.

**NOTE**

Please contact SCHUNK or the Service Centers if the results obtained are not in line with expectations. Please specify to the operator the model and serial number indicated on the product identification plate.

## 8. Troubleshooting

| Problem  | Corrective action   |
|--|---|
| Magnetization phase problems.                                      | See the use and maintenance manual of the control unit.   |
|  | Upper chuck : the workpiece is not positioned correctly. See the "Product description" paragraph.   |
|  | Lower chuck: check that there are no obstacles or shavings under the surface and remove them if necessary. See the "Product description" paragraph.   |
| The status of the magnetic chuck does not change.                  | Problem related to the electronic control unit. Consult the user manual of the unit.  |
|  | Problem related to status indicator malfunctioning. Contact the technical assistance service.   |
| The chuck has sections with damaged or burnt resin (darker resin). | Overheating of the resin, caused by too frequent MAG/DEMAG maneuvers or by excessively hot workpieces. To avoid these inconveniences, carry out MAG/DEMAG maneuvers spaced at least 3 minutes apart and use pole extensions to distance the piece from the resin. |

| NOTE  |  |
|---|--|
|  |  |

*For any contacts with the SCHUNK. Customer Assistance Service, please specify to the operator the model and serial number indicated on the product identification plate.*

## 9. Servicing and maintenance

Excellent and careful maintenance is a decisive factor for optimum safety, functioning and performance and a longer service life of the product.

| CAUTION   |   |
|---|---|
|  | <i>Maintenance work must only be carried out by qualified personnel. Every person appointed by the operator to carry out work on the product must have read and understood this manual in its entirety.</i> |

Please follow the instructions and maintenance intervals given in the table below so as to avoid repairs and resulting down-times, failures and inconvenience.

| NOTE   |  |
|--|--|
|  | <i>Defective electrical and electromechanical components must always be exchanged by SCHUNK Service personnel. If components are exchanged by the operator, this automatically renders the warranty invalid.</i> |

| Activity                          | Description  | Frequency                                |
|-----------------------------------|--|--|
| Cleaning the connector            | Check the connector for chips, dirt, etc. and remove as necessary                          | daily                                    |
| Check the rollers                 | Check the condition of the roller springs and their smoothness.                            | daily                                    |
| Checking the identification plate | Check that the identification plate is not damaged or illegible                            | daily                                    |
| Inspect seals                     | Check all the system seals (connectors, caps, housings, etc.).                             | weekly                                   |
| Checking the product              | Check the whole product for cracks, breaks or deformations                                 | monthly                                  |
| Checking the safety devices       | Check the safety devices upstream of the product for proper operation using suitable tests | According to specifications manufacturer |

## 10. Transportation and storage

| CAUTION   |  |
|---|--|
|  | <p><b><i>Risk of injury and damage to the product.</i></b><br/><i>During product transportation:</i></p> <ul style="list-style-type: none"><li>• <i>pay attention to the weight of the packing indicated on the transport documents</i></li><li>• <i>use the required personal protective equipment.</i></li></ul> |

In case of storage for long periods of time:

- store the product in its original packaging
- the product and the packaging should be inspected at regular intervals
- inspect packaging for outer damage and effects of the weather
- make sure that the temperature does not exceed values between +15°C and +70°C

| WARNING  |   |
|--|---|
|  | <p><b><i>Danger due to suspended loads.</i></b><br/><i>The product removal operation may require the intervention of several people and the use of handling devices such as lifting equipment, cranes, etc.</i></p> |

## 11. Disposal

At the end of its life cycle, the product must be decommissioned, i.e. placed in such conditions that it can no longer be used for the originally intended purpose, while allowing the recycling of the raw materials that compose it. Each raw material must be disposed of according to current legislation.

|   |   |
|---|---|
| <b>NOTE</b>   | <p><i>SCHUNK assumes no responsibility for material damage or personal injury that may result from reusing individual components of the product for purposes other than the original intended use. SCHUNK provides neither implicit nor explicit declarations about possible usability of recycled components after decommissioning of the product.</i></p> |
|  |   |

|  |   |
|--|---|
| <b>CAUTION</b>   | <p><b><i>Risk of injury.</i></b><br/> <i>The decommissioning, disassembly and disposal of the product must be carried out by qualified personnel equipped with the appropriate personal protective equipment.</i></p> |
|  |   |

- Stop the machine tool in complete safety and disconnect it from any electrical, hydraulic and pneumatic line and from all utilities.
- Entrust the disposal of the product to a company specialized in the disposal of electrical and magnetic equipment.

## 12. Spare parts

To purchase any spare parts, contact the SCHUNK Sales Department.