

Installation and operating instructions

SVAGG

Vacuum Unit

Original operating instructions

Hand in hand for tomorrow

Imprint

Copyright:

These instructions are protected by copyright. The copyright for this document belongs to SCHUNK SE & Co. KG.
All rights reserved.

Technical changes:

We reserve the right to make changes for technical improvements.

Document number: 0489078

Edition: 03.00 | 4/22/2025 | en-US

Dear Customer,

Dear Customer,

Thank you for showing your trust in our products and our family business as a leading technology supplier for robots and production machines.

Our team is always available to answer any questions you may have about this product and our other solutions. Ask us, and challenge us. We are here to solve your problem!

Kind regards,

Your SCHUNK team

Customer Management

Tel. +49 (0) 7572 7614 1300

Fax +49 (0) 7572 7614 1039

CMM@de.schunk.com



Please read the operating instructions in full and keep them close to the product.

Table of contents

1 General	5
1.1 About these instructions	5
1.2 Depiction of Warnings	5
1.3 Associated Documentation	6
1.4 Warranty	6
2 Fundamental Safety Instructions	7
2.1 Intended Use	7
2.2 Non-Intended Use.....	7
2.3 Personnel Qualifications	8
2.4 Residual Risks	9
2.5 Responsibility of the Integrator	9
2.6 Modifications to the Product.....	9
3 Product Description.....	10
3.1 Variants	10
3.2 Description of the Vacuum Unit	10
4 Technical Data	13
4.1 General Parameters	13
4.2 Dimensions.....	14
5 Transportation and Storage	15
5.1 Transport and Packaging.....	15
5.2 Checking the Delivery.....	15
6 Installation.....	16
6.1 Personnel Qualification	16
6.2 Installation Instructions.....	16
6.3 Electrical Connection.....	17
6.4 Fluid Connections.....	20
6.5 Functional Description.....	20
7 Start of Operations	24
7.1 Personnel Qualification	24
7.2 Before Initial Start of Operations.....	24
8 Operation	26
8.1 Preparations	26
8.2 Connecting to the Clamping Device	28
9 Troubleshooting.....	29
9.1 Safety	29

9.2	Faults, Causes, Solutions	29
10	Maintenance	31
10.1	Safety	31
10.2	Maintenance Schedule	31
10.3	Oil Quantity and Oil Change	32
10.4	Maintenance of Pump Oil	33
10.5	Emptying the Liquid Reservoir.....	34
11	Accessories, Spare Parts and Wearing Parts	35
12	Disposal	36

1 General

1.1 About these instructions

These instructions contain important information for safe and proper use of the product.

These instructions are an integral component of the product and must be stored in such a way that personnel can access them at any time. Before beginning any work, personnel must read these instructions and understand them. The prerequisite for safe work is complying with all of the safety information in these instructions. Illustrations in these instructions serve purposes of basic understanding and may vary from the actual version. In addition to these instructions, the documents listed in the section ▶ 1.3 [6] apply.

1.2 Depiction of Warnings

To elucidate hazards, the warnings use the following signal words and symbols.



⚠ DANGER

Hazards for people!

Non-compliance will certainly lead to irreversible injuries, up to and including death.



⚠ WARNING

Hazards for people!

Non-compliance can lead to irreversible injuries, up to and including death.



⚠ CAUTION

Hazards for people!

Non-compliance can lead to minor injuries.

NOTICE

Damage to property!

Information about avoiding damage to property.

1.3 Associated Documentation

- General terms and conditions *
- Catalog data sheet of the product purchased *
- Assembly and operating instructions for accessories *

The documents marked with an asterisk (*) can be downloaded on [schunk.com](https://www.schunk.com).

1.4 Warranty

The warranty is 12 months as of the ex-works delivery date in the event of proper use under the following conditions:

- Adhere to the environmental and operating conditions.
- Follow the stipulated maintenance intervals.

Parts that come into contact with workpieces and wearing parts are not covered by the warranty.

2 Fundamental Safety Instructions

2.1 Intended Use

The vacuum unit is used to control and maintain a specific vacuum and also serves as a liquid separator.

A prerequisite for operating the vacuum unit is a machine or system in accordance with Machinery Directive 2006/42/EC with suitable safety features.

The vacuum is used to fix suitable workpieces on a clamping device provided for this purpose. The vacuum unit is specially designed for the evacuation of media containing liquids and can therefore be used as a vacuum generator for machines during wet processing. Chippings or other small solids contained in the separated liquid are also separated from the evacuated medium and do not affect the function of the vacuum unit in small quantities. The water content of 70% must not be exceeded in the liquid.

The product is built in accordance with the latest standards of technology and is delivered in a safe operating condition; however, hazards may arise during use.

The integration of the vacuum unit into the complete machine is the responsibility of the manufacturer of the complete machine or the user of the machine.

Corresponding safety measures must be implemented on systems and devices used in connection with the vacuum unit in order to avoid danger to persons, animals or property caused by a loss of the operating vacuum.

The product is intended for industrial use.

Intended use includes observing the technical data and the installation and operating instructions in this manual.

Any other use is considered improper by the manufacturer and is deemed as contrary to the designated use.

2.2 Non-Intended Use

SCHUNK accepts no liability for damages caused by the use of the product for purposes other than those described under "Intended Use."

In particular, the following are considered non-intended use:

- Suction of body parts
- Use as a climbing aid
- Use of the product as a base, support or comparable aid
- Evacuation of objects that are in danger of imploding

- Use of the product in combination with easily flammable or potentially explosive materials such as acids or alkalis
- Unauthorized modifications or changes
- Pumping or recirculation of coolants/lubricants or other liquids, e.g. from a container
- Use as wet/dry vacuum

2.3 Personnel Qualifications

Unqualified personnel cannot recognize dangers and are therefore exposed to higher risks!

The system integrator must ensure the following points:

- The personnel must be commissioned for the activities described in these instructions.
- The staff must be at least 18 years of age and physically and mentally capable.
- The product must be operated only by persons who have undergone appropriate training.
- Personnel must receive regular safety briefings (frequency as per country-specific regulations).
- The product must be installed and maintained only by qualified electrical, pneumatic and mechanical specialists.

The operator of the system must comply with country-specific regulations regarding the age, ability and training of the personnel.

Applicable for Germany:

A qualified employee is defined as an employee who has received technical training and has the knowledge and experience – including knowledge of applicable regulations – necessary to enable him or her to recognize possible dangers and implement the appropriate safety measures while performing tasks. Qualified employees must observe the relevant industry-specific rules and regulations.

2.4 Residual Risks



⚠️ WARNING

Extraction of hazardous media, liquids or bulk material

Personal injury or damage to property!

- Do not extract harmful media such as dust, oil mists, vapors, aerosols etc.
- Do not extract aggressive gases or media such as acids, acid fumes, bases, biocides, disinfectants or detergents.
- Do not extract liquids or bulk materials, e.g. granulates.



⚠️ CAUTION

Noise pollution caused by exhaust air or leakage during operation

Hearing damage!

- In the event of leakage, check connections and lines and remedy leakages.
- Wear ear protection.

2.5 Responsibility of the Integrator

The operating company is obligated to perform a risk assessment for the environmental conditions at the installation location.

The operating company is also responsible for third parties in the working area of the vacuum unit. They must ensure that they have the appropriate qualifications and skills.

- Ensure that the vacuum unit cannot be started up by unauthorized persons.
- Ensure that the vacuum unit cannot be operated during maintenance or repair work.
- Clearly define the responsibilities for the various activities performed with the gripper.
- Ensure that these responsibilities are observed.

2.6 Modifications to the Product

SCHUNK assumes no liability for consequences of modifications over which it has no control:

1. The product must be operated only in its original condition as delivered.
2. Use only original spare parts from SCHUNK.
3. The product must be operated only in perfect condition.

3 Product Description

3.1 Variants

The vacuum unit SVAGG is available in four versions. The version is indicated in the item designation. The item designation is composed as follows:

Part no.	Designation	Vacuum pump
1563466	SVAGG 10-AC3-30-MD	SEVE-OG 10-AC3
1563467	SVAGG 21-AC3-30-MD	SEVE-OG 21-AC3
1563468	SVAGG 40-AC3-80-MD	SEVE-OG 40-AC3
1563469	SVAGG 63 AC3 80-MD	SEVE-OG 63-AC3

3.2 Description of the Vacuum Unit

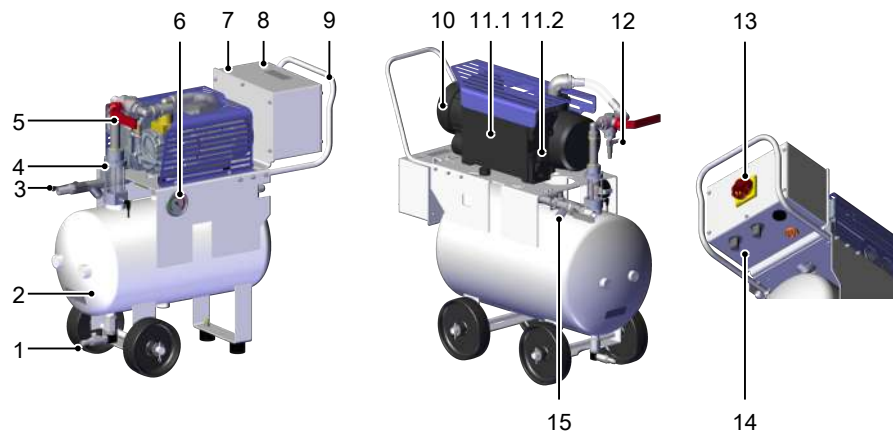

1	Manual blow-off valve with hose sleeve	9	Handle
2	Vacuum reservoir / liquid separator	10	Vacuum pump
3	Manual lever valve (vacuum ON/OFF) with hose sleeve	11.1	Oil level indicator (for variants 10 and 21)
4	Level indicator with float	11.2	Oil level indicator (for variants 40 and 63)
5	Manual lever valve (shut-off valve when compressed air is applied)	12	Compressed air connection including pressure-reduction valve
6	Vacuum gauge	13	Power switch
7	Electrical control box	14	Interface to machine
8	Pressure switch for energy-saving function	15	Pre-filter

The vacuum unit is used to control and maintain a specific vacuum level. It also serves as a liquid separator for evacuated liquid media with low to medium contamination levels.

The vacuum unit was developed for use on CNC machines and may be used only for this purpose ▶ 2.1 [7]. It constitutes the interface between the machine and the clamping system and, in conjunction with the clamping device, generates the required holding force between the clamping device and the workpiece.

The integrated vacuum pump achieves a max. vacuum of approx. -930 mbar and runs in continuous operation by default.

Depending on the conditions (e.g. the workpiece material, the condition of the seals, etc.), a permanent vacuum between -600 and -930 mbar is set.

The enable signal for processing can be queried by the interface to the machine. If the main switch is set to ON and the vacuum level is at least -600 mbar, the enable signal is present at the potential-free contact. If the vacuum level falls below this level, the device is switched off or is not supplied with voltage, which results in the contact being interrupted. The interface to the machine is 1-channel.

The medium evacuated using vacuum generation is fed away from the clamping system through the vacuum unit. Liquids contained in the evacuated medium are separated from the vacuum unit and collected in the storage reservoir. This protects the vacuum pump against the entry of liquids.

The level in the tank is monitored by a proximity sensor on the float. If the liquid level rises above the critical level, the pump is switched off in order to avoid damage caused by liquid that has been sucked in. The enable signal is maintained until the vacuum value drops below the level of -600 mbar, if appropriate.

Liquids entering the device can damage or even destroy the vacuum pump.

The liquid collected in the storage reservoir is drained manually via the blow-off valve. The process can be accelerated through the application of compressed air.

1. The vacuum unit must be switched off when doing so ▶ 10.5 [34].
2. The connection to the vacuum pump must be disconnected by means of the manual lever valve (item 5).

Energy-Saving Function

The vacuum unit is equipped with an energy-saving function. This function is activated by pressing the pressure switch on the electrical control box (item 8) and controlled by the integrated vacuum sensor. The vacuum pump is switched off when a vacuum of approx. -800 mbar is reached. If the vacuum falls below a level of -700 mbar due to leaks in the vacuum system, the vacuum pump is switched on automatically.

- The vacuum unit may be operated in energy-saving mode when the starting frequency is less than 10 starts per hour. At a higher starting frequency, the vacuum unit must be run in continuous operation.

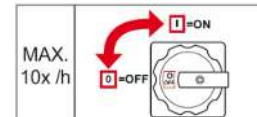

4 Technical Data

4.1 General Parameters

Description	SVAGG 10	SVAGG 21	SVAGG 40	SVAGG 63	Unit
Pump type	SEVE-OG 10	SEVE-OG 21	SEVE-OG 40	SEVE-OG 63	
Max. vacuum	930	930	930	930	mbar
Reservoir volume	30	30	80	80	l
Suction rate at 50 Hz	10	21	40	63	m ³ /h
Voltage at 50 Hz	Δ230/ Y400	Δ230/ Y400	Δ230/ Y400	Δ230/ Y400	V
Current range at 50 Hz	1.7/1.0	3.1/1.8	4.7/2.7	6.1/3.5	A
Sound level at 50 Hz	58.5	64	63	64	db/A
Weight	55	60	100	110	kg
Oil quantity	0.3	0.5	1.6	2	l
Vacuum connection clamping device	12	12	25	25	mm
Blow-off valve connector with hose sleeve	12	12	12	12	mm

4.2 Dimensions

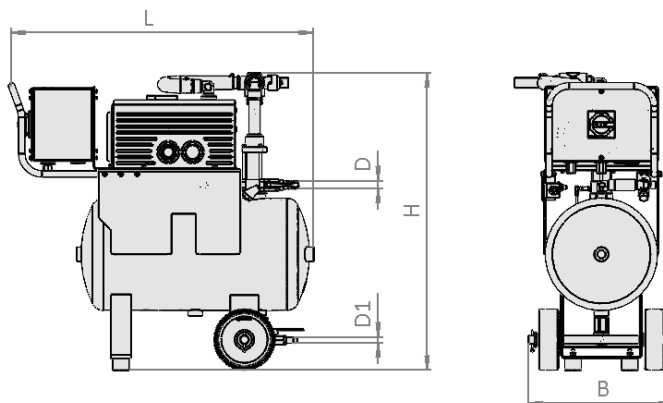

TYPE	L	B	H	D	D1
SVAGG 10	746	360	733	12	12
SVAGG 21	746	360	733	12	12
SVAGG 40	944	435	926	25	12
SVAAG 63	944	435	926	25	12

5 Transportation and Storage

5.1 Transport and Packaging

The transport route, the dimensions of the goods and the consignment weight determine the type of packaging. The vacuum unit is shipped from the factory standing upright, tied down on a pallet.

Carefully unpack the shipment, remove plastic films, cardboard boxes, straps and packing material.

Note:

The oil for the vacuum pump is supplied separately and must be poured into the pump of the vacuum unit in accordance with the applicable instruction manual (pump) before the start of operations.

For forwarding or return shipments, the oil must be drained again and the transportation aids and securing devices must be reattached ▶ 10.4 [33].

Internal Transport

The vacuum unit must always be transported in an upright position (even inside the factory); otherwise, the oil in the vacuum pump may leak out.

5.2 Checking the Delivery

The scope of delivery can be found in the order confirmation. The weights and dimensions are listed in the delivery notes.

The delivery includes a suitable vacuum hose with a length of 2 m and one connector for connecting the electrical signal lines.



1. Compare the entire delivery with the supplied delivery notes to make sure nothing is missing.
2. Damage caused by defective packaging or occurring in transit must be reported immediately to the carrier and SCHUNK.

6 Installation

6.1 Personnel Qualification

Unqualified personnel cannot recognize dangers and are therefore exposed to higher risks!

1. Only instruct qualified personnel to perform the tasks described in these operating instructions.
2. The product may only be operated by persons who have undergone appropriate training.
3. Electrical work and installations may only be carried out by qualified electrical specialists.
4. Assembly and maintenance work must only be carried out by qualified personnel.

6.2 Installation Instructions

Before the start of operations, the vacuum unit must be inspected for possible damage. Ensure that it is positioned on a solid, level surface.



⚠ CAUTION

Improper installation or maintenance

Injury to persons or damage to property

- During installation and maintenance, make sure that the product is disconnected and depressurized and that it cannot be switched on again without authorization.

To ensure safe installation, the following instructions must be observed:

- Use only the connectors, mounting holes and attachment materials that have been provided.
- Mounting and removal must be performed only when the device is unpressurized and disconnected from the mains.
- Pneumatic and electrical line connections must be securely connected and attached to the product.

6.3 Electrical Connection



⚠ DANGER

Electrocution by live components or wires

Serious injury or death!

- Electrical installation work may only be carried out by qualified personnel.
- Make sure that the electrical components are not live before installation, maintenance and troubleshooting.
- Switch off the mains switch and secure against unauthorized restart.

The electrical performance data can be found on the pump motor type plate.

The connection is made using a 5-pin CEE plug (400 V, 16 A).

- Power cables and other supply lines must be routed so that they do not cause tripping hazards and they must be protected against mechanical damage. It is advisable to lay them in a closed channel.

6.3.1 Checking the Direction of Rotation of the Vacuum Pump

The vacuum pump is supplied with a clockwise rotation field. The prescribed direction of rotation is indicated by an arrow on the motor housing.

1. Switch on the vacuum unit using the power switch on the electrical control box.
2. Observe the direction of rotation of the fan blade of the motor on the vacuum pump.

Directional arrow

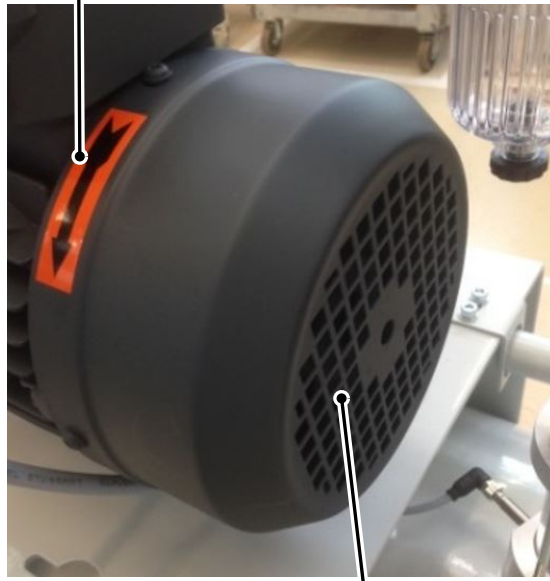

View of the fan blade

3. If the direction of rotation on the vacuum unit is incorrect, switch it off immediately and reverse the connection in the power plug.
4. Check the direction of rotation once again.

6.3.2 Connecting the Signal-emitting Electrical Line

The vacuum unit has a plug connector with a potential-free contact. This gives the customer the enable signal for processing. This plug connector must be integrated into the higher-level control.

The potential-free contact is only closed if the following conditions are present:

- the -XD1 connector is plugged in
- the -QB1 main switch is on
- the vacuum level is >600 mbar

The contact is interrupted as soon as the vacuum level is <600 mbar or the fill level sensor reports a critical fill level.

If the enable signal is interrupted during operation, the machining process must be interrupted as soon as possible since the workpiece may no longer be clamped reliably.

Connector

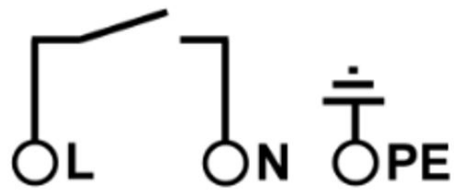

1. Connect the supplied mating connector to a three-wire cable (L connection, N connection and protective ground).
2. Check the switching process with a continuity tester (between L and N) by activating and deactivating the vacuum supply.
3. Integrate the signal into the machine controller so that when the signal is interrupted ...
 - ⇒ processing is stopped and
 - ⇒ the operator is notified of the error message and interrupts processing at the next possible time.

6.4 Fluid Connections



⚠ CAUTION

Compressed air or vacuum in direct contact with the eye

Severe eye injury

- Wear eye protection
- Do not look into compressed air openings
- Do not look into the silencer air stream
- Do not look into vacuum openings such as suction cups, suction lines and hoses.



⚠ CAUTION

Noise pollution due to incorrect installation of the pressure and vacuum connections

Hearing damage!

- Correct installation.
- Wear ear protectors.

6.4.1 Vacuum Connection

The vacuum unit is connected to the clamping equipment through the vacuum connection ▶ 3.2 [10].

The appropriate vacuum hose (2 m) is included in the delivery.

6.4.2 Compressed Air Connection

To speed up the draining process, the boiler can be supplied with compressed air. To do so, connect the compressed air to the pressure-reduction valve connector ▶ 3.2 [10]. The pressure-reduction valve is set to 0.5 bar of output pressure.

This value must not be changed!

The maximum input pressure is 0.5 bar.

6.5 Functional Description

6.5.1 Vacuum Monitoring



⚠ WARNING

Flying workpiece due to insufficient vacuum clamping force during machining, resulting from insufficient vacuum.

Risk of injury due to flying workpiece

- Monitor the vacuum value as close to the clamping location as possible
- Wear personal protective clothing

The vacuum unit is operated in continuous operation by default. After switching on, the vacuum pump builds a vacuum up to approx. -930 mbar. After opening the vacuum connection, the vacuum will drop slightly depending on the seal tightness (e.g. the seal tightness of the workpiece, the condition of the seals, etc.) of the vacuum system.

The generated operating vacuum is monitored via an integrated vacuum sensor.

If the vacuum falls below the critical level of -600 mbar, the audible warning device sounds and the output for enabling the machine is interrupted.

Vacuum Monitoring

- Switch on the energy saving function by pressing the pressure switch.
- The vacuum unit then automatically switches off to save energy (integrated energy-saving function) after reaching a vacuum level of -800 mbar.
- If the vacuum drops below -700 mbar due to leakage, the vacuum pump switches on again automatically.
- If the vacuum level falls below -600 mbar, an audible warning signal is activated and the electrical signal for enabling the machine is interrupted.

Checking the Operating Vacuum

The function of the vacuum unit for the purposes of vacuum generation is tested as described below:

- 1.** Close the blow-off valve and the manual lever valve for the vacuum connection.
- 2.** Switch on the vacuum unit at the power switch. An audible warning signal sounds.
- 3.** Monitor the build-up of the operating vacuum on the integrated gauge. The warning signal must sound until the operating vacuum of -600 mbar is built up.
- 4.** The vacuum unit runs in continuous operation and a maximum, constant vacuum of approx. -930 mbar is built up.

The vacuum reached should not drop by more than 100 mbar within the next 20 minutes.

6.5.2 Fill Level Monitor for the Liquid Separator

Any liquid contained in the suctioned media is collected in the liquid separator. The level of the liquid can be observed using the visual fill level indicator in the sight glass. When the critical filling level V1 is reached, the vacuum pump is switched off in order to avoid damage caused by liquid that is sucked in. The pump cannot be restarted until the fluid level falls below this critical level.

The accumulated liquid must be drained from the storage reservoir through the blow-off valve when the device is switched off ▶ 10.5 [34].

If the fill level continues to rise, a safety valve prevents the vacuum pump (8) from being damaged and closes off the vacuum circuit, and the enable signal on the signal line for the machine goes out.



⚠ WARNING

The liquid level rises above the critical fill level

Danger of injury due to workpiece loss, sudden collapse in vacuum => loss of holding force

- Turn off the machine and stop the machining process!

Fill Level Monitoring Check

Check the fill level monitoring function of the liquid separator as follows:

1. Close the drain valve and the manual lever valve for the vacuum connection.
 2. Switch on the vacuum unit at the power switch. An audible warning signal sounds.
 3. After the operating vacuum is reached, connect the supplied vacuum hose to the suction connection and immerse it in a container filled with cooling lubricant.
 4. Carefully open the suction connection and suck in the cooling lubricant.
 5. Observe the visual level indicator; the measuring stick should rise.
- ⇒ When the critical filling level is reached, the vacuum pump is designed to protect against liquid that has been sucked in.
- ⇒ If the vacuum level drops below 600 mbar, the audible warning signal sounds and the processing enable signal is interrupted.

The critical fill level is marked in red on the measuring stick in the sight glass.

1. Close the suction connection.
2. Switch off the vacuum unit at the power switch.
3. Vent the system by opening the suction connection to the atmosphere
4. Before opening the blow-off valve, ensure that the operating vacuum has completely dispersed.
5. Open the 3/2-multiway valve to vent the boiler or apply compressed air to it.
6. Open the blow-off valve and empty the liquid reservoir.

6.5.3 Audible Warning Device/Output for Enabling the Machine

Checking the function of the audible warning device and the machine enable output:

1. Close the blow-off valve and the manual lever valve for the vacuum connection.
 2. Switch on the vacuum unit at the power switch. An audible warning signal sounds.
 3. Monitor the build-up of the operating vacuum on the integrated gauge. The warning signal must sound until the operating vacuum of -600 mbar is built up.
The output for enabling the machine is interrupted (no electrical signal "0").
 4. When -600 mbar is reached, the alarm becomes silent and the signal output for enabling the machine is activated (electrical signal "1").
- ⇒ The vacuum unit remains in continuous operation and increases the vacuum until it reaches a constant vacuum level at around -930 mbar.
- ⇒ When operating on a clamping device with open vacuum connection, the vacuum usually falls below this level.
- ⇒ If the operating vacuum falls back below -600 mbar, then the alarm sounds again and the machine enable is interrupted.

7 Start of Operations

7.1 Personnel Qualification

Unqualified personnel cannot recognize dangers and are therefore exposed to higher risks!

1. Only instruct qualified personnel to perform the tasks described in these operating instructions.
2. The product may only be operated by persons who have undergone appropriate training.
3. Electrical work and installations may only be carried out by qualified electrical specialists.
4. Assembly and maintenance work must only be carried out by qualified personnel.

7.2 Before Initial Start of Operations

Before the initial start of operations following installation, repair, servicing or maintenance work, you must check the following:

- All mechanical connectors are properly attached and secured.
- All screws and nuts are tightened to specified torques.
- All components are installed.
- The safety distances have been maintained.
- The electrical cable and supply hoses are properly routed.
- The EMERGENCY STOP switch for the overall system is working.
- The type plate is clearly legible.



⚠ DANGER

Electric shock from touching live electrical components

Serious injury or death!

- Make sure that the electrical components are not live before installation, maintenance and troubleshooting.
- Switch off the mains switch and secure against unauthorized restart.



⚠ CAUTION

Noise pollution due to incorrect installation of the pressure and vacuum connections

Hearing damage!

- Correct installation.
- Wear ear protectors.



⚠ CAUTION

Vacuum close to the eye

Severe eye injury!

- Wear eye protection.
 - Do not look into vacuum openings, e.g. suction cups.
-

8 Operation

8.1 Preparations



⚠ DANGER

Releasing the workpiece from the clamping table

Serious injury or death!

- The vacuum level in the machine tool must be measured directly on the vacuum clamping device.
- The vacuum sensors on the clamping device and vacuum generator are connected to the system controller. The signals must be correctly evaluated and processed by the controller.



⚠ CAUTION

Injury to persons and/or damage to property due to unexpected malfunctions

- Following a vacuum supply system failure or malfunction, carry out the process of clamping the workpiece again from the very start.
- Restore the vacuum supply.
- Check the system for software errors (machine controller switching functions).



⚠ CAUTION

Touching hot surfaces

Touching hot surfaces may cause injury from burns.

- Wear work gloves.
- Do not touch components during operation.
- Allow the components to cool down before commencing work on the product.



⚠ CAUTION

The discharged gas contains minimal amounts of oil.

Health risk

- If the air is directed into rooms where people are present, ensure adequate ventilation.
- The product must only be operated by persons who have undergone appropriate training.

Before starting up the vacuum unit, ensure that you are familiar with the following:

1. All aspects of the vacuum unit
2. The machine equipment and fittings
3. Operating mode of the vacuum unit
4. The immediate surroundings of the vacuum unit, and the machine or system in which the vacuum unit is used
5. The safety features on the machine
6. Measures to be taken in the event of an emergency

Carry out the following tasks before each machine start:

1. Ensure that all safety features are present and fully functional.
2. Check the vacuum unit for visible damage and deal with any problems immediately (or notify your supervisor).
3. The vacuum unit and machine may only be operated when they are in perfect condition.
4. Ensure that only authorized personnel are present in the working area of the machine or system and that no other personnel are put in danger by switching on the machine.
5. Ensure that the liquid reservoir is emptied appropriately.
6. Ensure that the work area is adequately ventilated.

To process workpieces on the complete machine, we recommend an operating vacuum of at least -750 mbar. The operating vacuum should not fall below the minimum value of -600 mbar. The vacuum is monitored by the vacuum switch.

We recommend measuring the vacuum directly on the clamping device and as close to the workpiece as possible.

A vacuum drop may cause the workpiece that is being machined on the machine table to move or even be released.

Possible causes for a drop in vacuum include:

- Power failure
- Drop in compressed air level
- Critical liquid level exceeded
- Line break
- Malfunction

8.2 Connecting to the Clamping Device

1. Connect the vacuum hose included in the delivery to the vacuum connection on the vacuum unit and to the vacuum clamping device.
2. The valves must be closed. The electrical supply must be present, and the safety features must be integrated in the machine controller.
3. Switch on the vacuum unit at the power switch.
4. Once a constant vacuum above -600 mbar has been established (see gauge), open the suction connection (vacuum ON).

The vacuum is then supplied to the vacuum clamping system and monitored by the safety features on the vacuum unit. Any liquid picked up is separated and collected in the reservoir.

A workpiece positioned on the vacuum clamping device is held/ clamped by the negative pressure generated.

9 Troubleshooting

9.1 Safety

Maintenance work may only be carried out by qualified personnel.



⚠ WARNING

Risk of injury due to incorrect maintenance or troubleshooting

- Check the proper functioning of the product, especially the safety features, after every maintenance or troubleshooting operation.



⚠ CAUTION

Improper installation or maintenance

Personal injury or damage to property

- Prior to installation and before maintenance work, the product must be disconnected from the power supply, depressurized (vented to the atmosphere) and secured against unauthorized restart.



⚠ CAUTION

Touching hot surfaces

Touching hot surfaces may cause injury from burns.

- Wear work gloves.
- Do not touch components during operation.
- Allow the components to cool down before commencing work on the product.

9.2 Faults, Causes, Solutions

Error	Possible cause	Solution
Vacuum unit does not start	Electrical connection incorrect or faulty	Check the connection and correct it if necessary.
	Power supply interrupted	Check power supply line.
	Voltage only on two phases	Check the fuse and connection.
	Machine protection switch triggered	Check whether the motor is overloaded or defective. Let the motor cool down. Correct the current on the motor-protection switch if

Error	Possible cause	Solution
		necessary and switch on the motor-protection switch.
Pump runs but vacuum does not reach -600 mbar	Motor's direction of rotation reversed	Reverse the polarity of connection line.
	Excessive leakage in the system	Check the vacuum unit and clamping system for leaks.
	Blow-off valve is open	Close the blow-off valve.
	The ventilation valve is in the ventilation position	Check and correct the position of the ventilation valve
No suction, despite presence of vacuum	Contamination in the lines, or other narrowing of the cross-section caused by dirt	Clean the lines.
	Vacuum openings on the clamping system are dirty	Clean the vacuum openings.
	Vacuum hose kinked	Lay vacuum hose without kinking.
No audible warning signal	Vacuum sensor does not respond	Contact your SCHUNK contact person.
	Fill level sensor does not react	
	Float does not move, despite rising fill level	
Liquid in the pump oil	Water or droplet separator full	Empty and clean the water and droplet separator.
	Liquid in the vacuum pump has not been discharged	Clean the oil (see the instruction manual for the relevant vacuum pump)
	Gas ballast valves on vacuum pump faulty	Replace the gas ballast valves

10 Maintenance

10.1 Safety

Maintenance work may only be carried out by qualified personnel.



⚠ WARNING

Risk of injury due to incorrect maintenance or troubleshooting

- Check the proper functioning of the product, especially the safety features, after every maintenance or troubleshooting operation.



⚠ CAUTION

Improper installation or maintenance

Personal injury or damage to property

- Prior to installation and before maintenance work, the product must be disconnected from the power supply, depressurized (vented to the atmosphere) and secured against unauthorized restart.



⚠ CAUTION

Touching hot surfaces

Touching hot surfaces may cause injury from burns.

- Wear work gloves.
- Do not touch components during operation.
- Allow the components to cool down before commencing work on the product.

10.2 Maintenance Schedule

SCHUNK stipulates the following checks and inspection intervals. The operator must comply with the legal regulations and safety regulations applicable at the location of use. These intervals apply to single-shift operation. For heavier use such as multi-shift operation, the intervals must be shortened accordingly.

Maintenance task	Weekly	Monthly	Quarterly
Clean pre-filter.		X *	
Oil change on vacuum pump		▶ 10.3 [32]	

* You may have to clean the pre-filter more frequently.

10.3 Oil Quantity and Oil Change



⚠ WARNING

Waste oil gets into the environment

Risk to health and the environment

- Proper disposal of the waste oil according to the country-specific and official regulations

The maintenance intervals are very dependent on the individual operating conditions. The following values are initial values that can be shortened as necessary. Operation under difficult conditions, such as high dust levels in the environment or contamination or product ingress in the gas to be pumped, may make it necessary to shorten the maintenance intervals.

- Check the fill level and the color of the oil daily with the vacuum pump (10) switched off.
The oil level should not fall below the center of the oil sight glass (10.1).

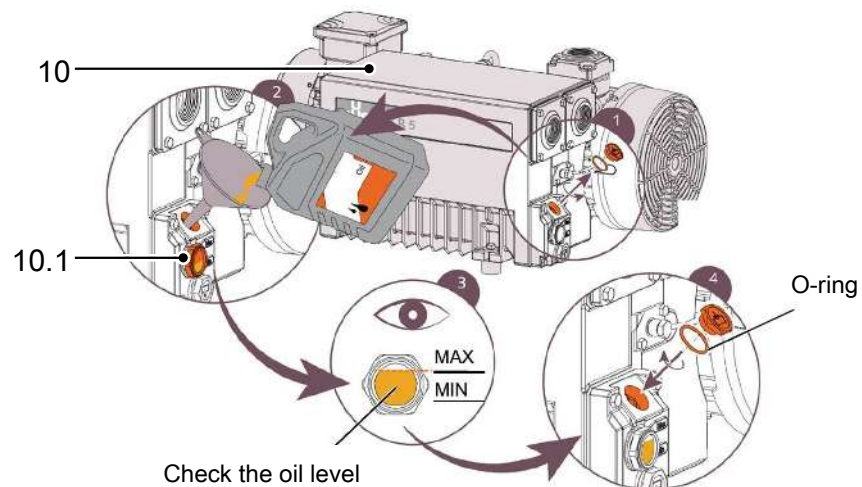

To ensure the pump function, it is necessary to change the oil and the oil filter at the following time intervals:

- First oil change after 100 hours of operation
- Then every 500 to 1000 hours
- At least every six months
- If the liquid intake is too high

You must also follow the maintenance instructions in the instruction manual for whichever vacuum pump you are using.

10.4 Maintenance of Pump Oil

NOTICE

Insufficient or incorrect maintenance of the pump oil

Damage to the vacuum pump

- Observe the maintenance instructions of the pump manufacturer
-

To separate the oil in the vacuum pump from condensed liquids, the oil must be serviced at regular intervals.

With the help of the gas ballast valve, the accumulation of condensates from the process gas in the vacuum pump is counteracted.

Existing condensates can be separated from the oil and transported out of the pump:

1. Check that the storage reservoir is empty and contains no liquids.
2. Disconnect the vacuum unit from the vacuum circuit by closing the manual valve.
3. The manual blow-off valve must be closed.
4. Switch on the vacuum unit with the power plug and run it in continuous operation.
5. The vacuum unit now generates a negative pressure. Leave this state activated for about 20 minutes with the pump running constantly.

The maintenance takes approx. 20 min.

This process must be repeated at regular intervals:

- Daily, based on a 1-shift system (8 h)
- After ingress of liquid (check with oil level indicator)

10.5 Emptying the Liquid Reservoir

NOTICE

Open the blow-off valve when there is a vacuum in the storage reservoir

Ignore the audible liquid fill level warning

Separated liquid is drawn into the vacuum pump and leads to the destruction of the pump motor.

- Make sure that the power plug is OFF before each blow-off process.
- Make sure that the manual lever valve is open before each blow-off process.
- When the audible liquid warning is triggered, stop processing immediately.

The liquid reservoir should be regularly checked with regard to the fill level of the separated liquid. It should be sufficiently empty before starting processing.

The storage reservoir must be emptied immediately as follows when it has reached a critical level:

1. Switch off the vacuum unit and vent the tank by opening the 3/2-multiway valve or fill it with compressed air.
 - The vacuum in the reservoir is regulated and the entire system is subjected to ambient pressure or 0.5 bar of vacuum.
2. Position a suitable container for collecting the liquid next to or below the blow-off valve.
3. Drain the liquid into the container by carefully opening the blow-off valve.

A small piece of hose mounted on the drain valve makes it easier to drain the liquid.

When compressed air is used to empty the container, a height difference of up to 4 m can be overcome during emptying, allowing the liquid to be pumped off into a reservoir at a higher level.

11 Accessories, Spare Parts and Wearing Parts

Accessories, spare parts, and wearing parts can be requested using the order number, product key, or SCHUNK product service number.

Part no.	Designation	Note	Type
1563500	Vacuum pump SEVE-OG 10-AC3		S
1563501	Vacuum pump SEVE-OG 21-AC3		S
1563502	Vacuum pump SEVE-OG 40-AC3		S
1563503	Vacuum pump SEVE-OG 63-AC3		S
1563753	Gas ballast valve	for SEVE-OG 40	S
1563754	Gas ballast valve	for SEVE-OG 63	S
1566888	Pump wearing part set VST SEVE-OG-10	Air-oil separator SEVE-OG 10	V
1566889	Pump wearing part set VST SEVE-OG-21	Air-oil separator SEVE-OG 21	V
1563692	Filter insert (round)	for SEVE-OG 40	S
1563693	Filter insert (round)	for SEVE-OG 63	S
1563633	Replacement screen	for SEVE-OG 10 / 21	S
1563634	Replacement screen	for SEVE-OG 40 / 63	S
1470088	Float	for all SEVE-OG units	S
1326544	PLANOS-Oil, 1 liter	for all SEVE-OG units	V

A = accessory part, S = spare part, W = wearing part

12 Disposal

Recover the disassembled parts for recycling or reuse (provided no agreement on return or disposal has been made).

1. Dispose of the product properly after replacement or decommissioning.
2. Observe the country-specific guidelines and legal obligations for waste prevention and disposal.

For proper disposal, please contact a company specializing in the disposal of technical goods and instruct the company to observe the applicable disposal and environmental regulations. SCHUNK is happy to assist you in finding a suitable company.

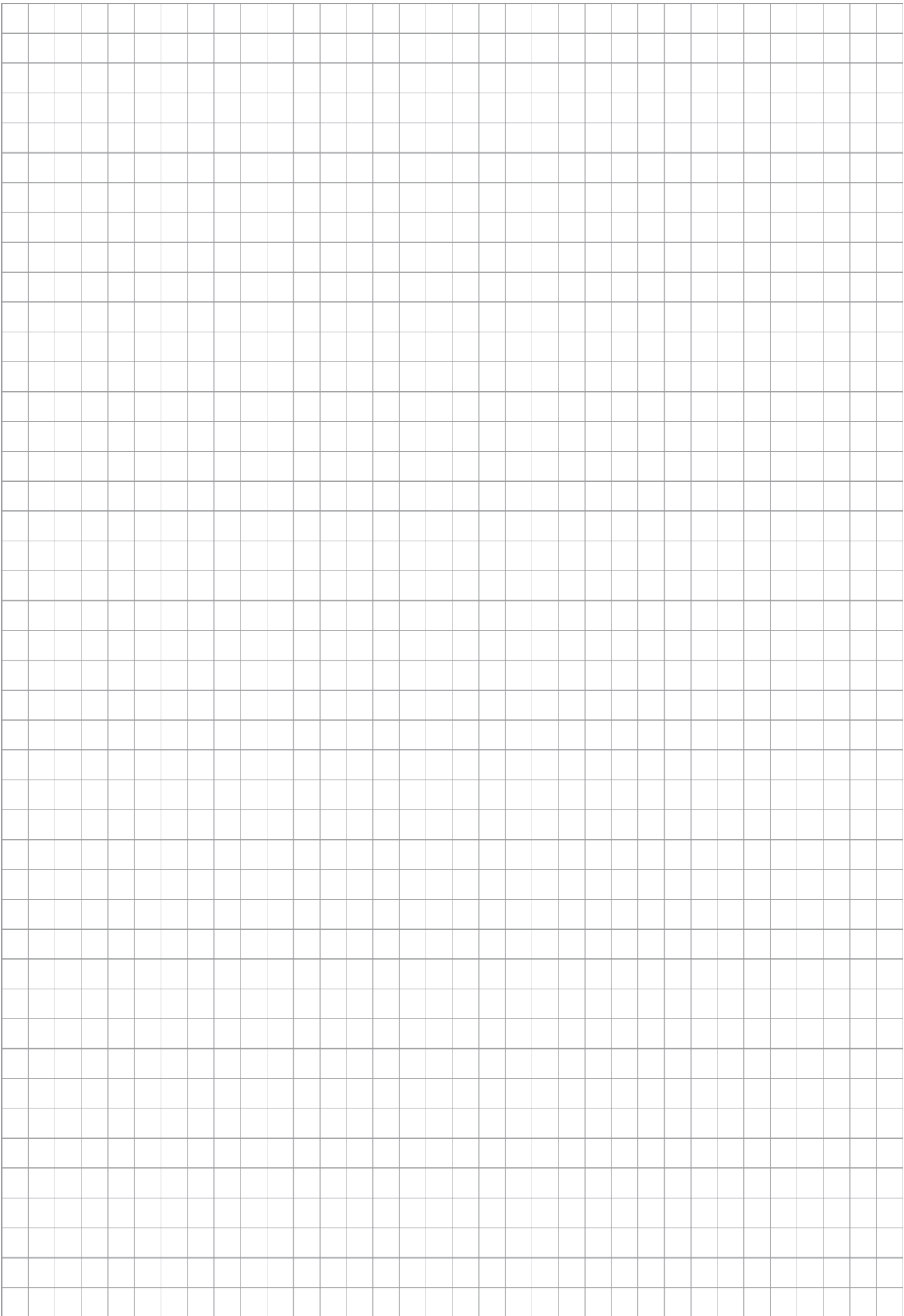

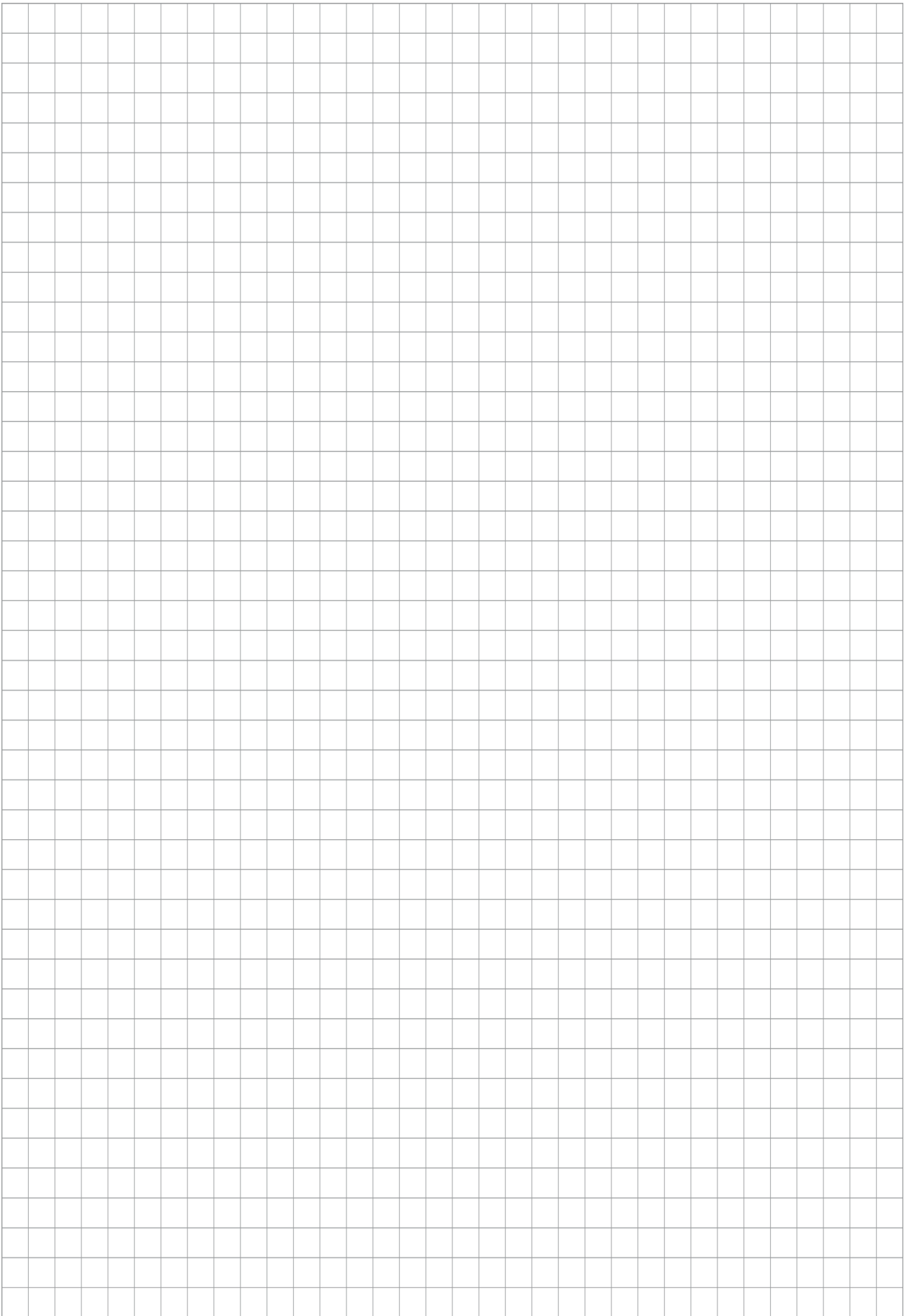





H.-D. SCHUNK GmbH & Co.
Spanntechnik KG

Lothringer Str. 23
D-88512 Mengen
Tel. +49-7572-7614-1300
info@de.schunk.com
schunk.com

Folgen Sie uns | *Follow us*



Wir drucken nachhaltig | *We print sustainable*