

# Assembly and Operating Manual

## NI

### Inductive proximity sensor

Translation of Original Operating  
Manual

Hand in hand for tomorrow

## Imprint

### Copyright:

This manual is protected by copyright. The author is SCHUNK SE & Co. KG.  
All rights reserved.

### Technical changes:

We reserve the right to make alterations for the purpose of technical improvement.

**Document number:** 1604659

**Version:** 01.00 | 15/10/2024 | en

Dear Customer,

Thank you for trusting our products and our family-owned company, the leading technology supplier of robots and production machines.

Our team is always available to answer any questions on this product and other solutions. Ask us questions and challenge us. We will find a solution!

Best regards,

Your SCHUNK team

Customer Management

Tel. +49-7133-103-2503

Fax +49-7133-103-2189

cmg@de.schunk.com



**Please read the operating manual in full and keep it close to the product.**

# 1 General

## 1.1 About this manual

This manual contains important information for a safe and appropriate use of the product.

This manual is an integral part of the product and must be kept accessible for the personnel at all times.

Before starting work, the personnel must have read and understood this operating manual. Prerequisite for safe working is the observance of all safety instructions in this manual.

### 1.1.1 Presentation of Warning Labels

To make risks clear, the following signal words and symbols are used for safety notes.

#### **CAUTION**

##### **Material damage!**

Information about avoiding material damage.

---

### 1.1.2 Applicable documents

- General terms of business \*
- Catalog data sheet of the purchased product \*
- Assembly- and Operating Manual of the SCHUNK-module, on which the sensor is mounted \*

The documents labeled with an asterisk (\*) can be downloaded from [schunk.com/downloads](https://www.schunk.com/downloads).

## 1.2 Warranty

If the product is used as intended, the warranty is valid for 24 months from the ex-works delivery date under the following conditions:

- Observe the applicable documents, ▶ 1.1.2 [ 3 ]
- Observe the ambient conditions and operating conditions, ▶ 2.3 [ 4 ]

## 1.3 Scope of delivery

The scope of delivery includes

- Inductive proximity sensor NI in the version ordered
- Mechanical connection
- Safety information (product-specific instructions available online)

## 2 Basic safety notes

### 2.1 Intended use

The sensor is used for sensing a position of a SCHUNK product via a switching lug or control cam.

- The product is intended for installation in a machine/ automated system. The applicable guidelines for the machine/ automated system must be observed and complied with.
- The product may only be used within the scope of its technical data, ▶ 3 [ 6].

### 2.2 Inappropriate use

The product is not a safety component in accordance with the EC Machine Directive 2006/42/EC and must not be used in safety-relevant parts of machine control units.

### 2.3 Environmental and operating conditions

#### Required ambient conditions and operating conditions

Incorrect ambient and operating conditions can make the product unsafe, leading to the risk of serious injuries, considerable material damage and/or a significant reduction to the product's life span.

- Make sure that the product is used only in the context of its defined application parameters, ▶ 3 [ 6].
- Make sure that the environment is free from splash water and vapors as well as from abrasion or processing dust. Exceptions are products that are designed especially for contaminated environments.

### 2.4 Constructional changes

#### Implementation of structural changes

Modifications, changes or reworking, e.g. additional threads, holes, or safety devices, can damage the product or impair its functionality or safety.

- Structural changes should only be made with the written approval of SCHUNK.

## 2.5 Personnel qualification

### Inadequate qualifications of the personnel

If the personnel working with the product is not sufficiently qualified, the result may be serious injuries and significant property damage.

- All work may only be performed by qualified personnel.
- Before working with the product, the personnel must have read and understood the complete assembly and operating manual.
- Observe the national safety regulations and rules and general safety instructions.

### 3 Technical data

Designation	NI
Ambient temperature [°C]	
Min.	- 20
Max.	+ 80
Nominal voltage [VDC]	24
Min.	10
Max.	30
IP rating	67

More technical data is included in the catalog data sheet. Whichever is the latest version.

## 4 Assembly and settings

### 4.1 Mechanical connection

#### NOTE

The assembly instructions in this chapter are generally applicable.

Module-specific assembly instructions for the sensor can be found in the Assembly and Operating Manual for the module, which can be downloaded at [schunk.com](http://schunk.com)

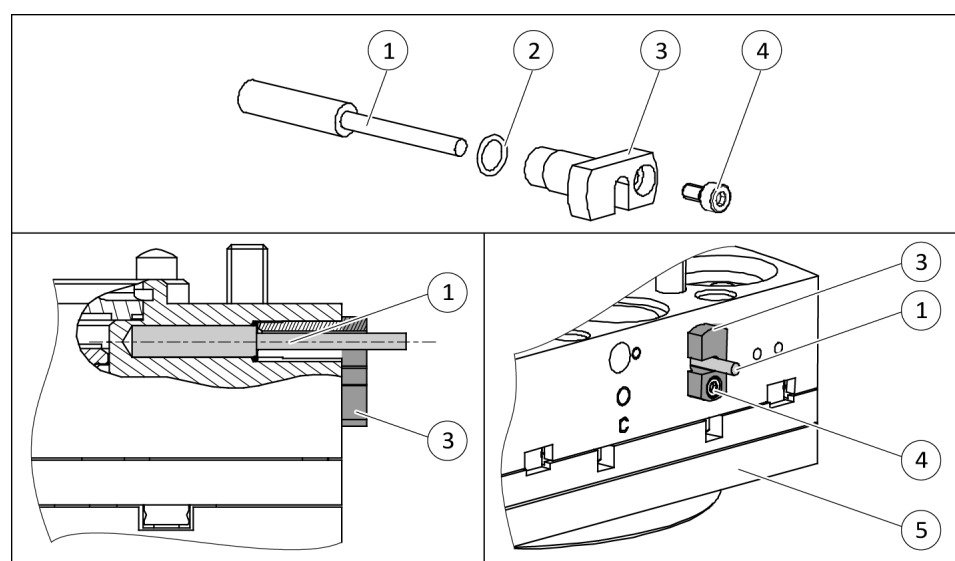

1. Slide O-ring (2) onto the sensor (1).
2. Connect sensor (1).
3. Lay the sensor cable (1) in the nut of the clamping element (3).
4. Slide sensor (1) into the bore hole of the housing (5) until it stops.
5. Slide clamping elements (3) into the bore hole of the housing (5) and slightly tighten the screw (4).
  - ⇒ The O-ring (2) is between sensor (1) and bracket (3).
6. Turn sensor (1) on its axis until sensor (1) switches.
7. Screw bracket (3) with the screw (4).
  - ⇒ The sensor (1) is fixed.

## 4.2 Electrical connection

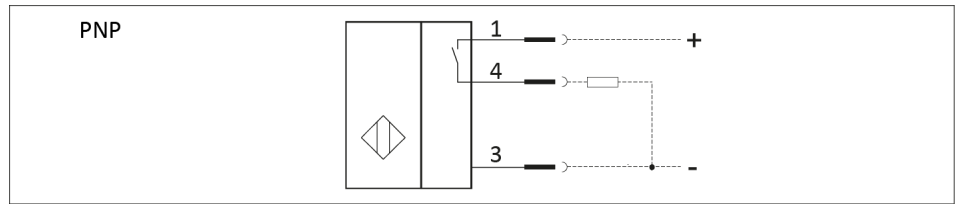

**Type of switching:** PNP

**Switching function:** Closer

M8 connector

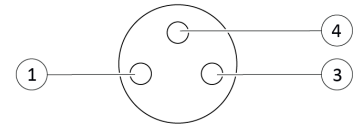
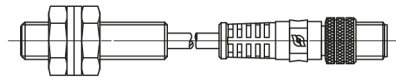

1	Brown	+ 10 to 30 V DC	4	Black	Output
3	Blue	GND			

## 4.3 Installing and connecting the sensor

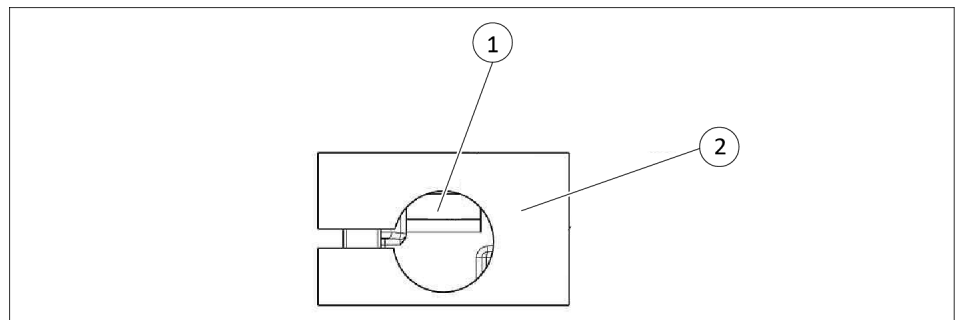

*Place the control cam under the bracket*

- 1.** Place the control cam (1) directly under the bracket (2).
- 2.** Insert the sensor into the bracket (2) until it contacts the control cam (1).
- 3.** Pull the sensor (1) back until it no longer contacts the control cam.
- 4.** Tighten the screws of the bracket (2).
- 5.** Connect the sensor and fasten the cable.

## 5 Troubleshooting

### 5.1 Sensor not operating

Possible cause	Corrective action
• No control cam available	Check whether the control cam is present.
• Cable breakage	Check whether the sensor cable is broken.
• No voltage or voltage too low	Check whether the voltage at the sensor is between 10 – 30 VDC. Remove the sensor from the module, see the Assembly and Operating Manual for the module. Connect the sensor to the power supply. Touch a level metal surface with the front of the sensor and check whether the LED lights up on the sensor. Install the sensor on the module, see the Assembly and Operating Manual for the module. Check whether the LED lights up at the position to be sensed and that the sensor is operating.

#### NOTE

If the LED does not light up or the sensor is not operating, contact SCHUNK Service.

### 5.2 Sensor is operating, but not as desired

Possible cause	Sources of interference	Corrective action
The sensor is interfered with or influenced by external magnetic or soft magnetic materials (Fe).	Motors (coils)	Increase the distance between the sensor and the mentioned sources of interference (until the sensor switches correctly).
	Relays	
	Linear motors	
	Electrical welding	
	Magnetized components and workpieces (workpieces made of iron or similar materials)	
	Magnetized components and tools (adapter plates made of iron, iron screws or iron hexagon socket keys, etc.)	Use components containing aluminum. For example, V4A screws are recommended.
The sensor is influenced by a different sensor.	Same or similar product	Increase the distance between the sensors to at least 2 mm.

<b>Possible cause</b>	<b>Sources of interference</b>	<b>Corrective action</b>
The sensor is affected by deposits of magnetic shavings in the vicinity (in the air gap).	Liquids with magnetic particles or the like.	Regularly clean the immediate environment of the sensor. The higher the exposure to such fluids, the more often it needs to be cleaned.

---

**NOTE**

If these steps do not eliminate the problem, contact SCHUNK Service for troubleshooting.

---

## 6 EU Declaration of Conformity

Manufacturer/ Distributor	SCHUNK SE & Co. KG Spanntechnik   Greiftechnik   Automatisierungstechnik Bahnhofstr. 106 – 134 D-74348 Lauffen/Neckar
Product designation:	Inductive proximity sensor NI
ID number	0313426, 0313429, 0313425, 0313431, 0315495, 0319456, 1353751

We hereby declare on our sole authority that the product meets the requirements of the following directives at the time of the declaration.

The declaration is rendered invalid if modifications are made to the product.

- **Electromagnetic compatibility (EMC directive) 2014/30/EU**

Applied harmonized standards, especially:

EN IEC 61000-6-2:2019	Electromagnetic compatibility (EMC) – Part 6-2: Generic standards – Immunity standard for industrial environments
EN 61000-6-4:2007 + A1:2011	Electromagnetic compatibility (EMC) – Part 6-4: Generic standards – Emission standard for industrial environments (IEC 61000-6-4:2006 + A1:2010);
EN 60947-5-2:2007 + A1:2012	Low-voltage switchgear and controlgear – part 5-2: circuit devices and switching elements – Proximity switches (IEC 60947-5-2:2007 + A1:2012)

Signed for and on behalf of: SCHUNK SE & Co. KG

Lauffen/Neckar, October 2024

i.V. Nico Peper;  
Director Software and Electronics;  
Technology & Innovation

## 7 UKCA Declaration of Conformity

Manufacturer/ Distributor	SCHUNK Intec Limited Clamping and gripping technology 3 Drakes Mews, Crownhill MK8 0ER Milton Keynes
Product designation:	Inductive proximity sensor NI
ID number	0313426, 0313429, 0313425, 0313431, 0315495, 0319456, 1353751

We hereby declare that the product complies with all relevant harmonization legislation of the following directives at the time of declaration.

The declaration is rendered invalid if modifications are made to the product.

- **Electromagnetic Compatibility Regulations 2016**

Applied harmonized standards, especially:

EN IEC 61000-6-2:2019	Electromagnetic compatibility (EMC) – Part 6-2: Generic standards – Immunity standard for industrial environments
EN 61000-6-4:2007 + A1:2011	Electromagnetic compatibility (EMC) – Part 6-4: Generic standards – Emission standard for industrial environments (IEC 61000-6-4:2006 + A1:2010);
EN 60947-5-2:2007 + A1:2012	Low-voltage switchgear and controlgear – part 5-2: circuit devices and switching elements – Proximity switches (IEC 60947-5-2:2007 + A1:2012)

Person authorized to compile the technical documentation:  
Marcel Machado, address: refer to manufacturer's address

Signed for and on behalf of: SCHUNK SE & Co. KG

Lauffen/Neckar, October 2024



i.V. Nico Peper;  
Director Software and Electronics;  
Technology & Innovation

## 8 Information on the RoHS Directive, REACH Regulation and Substances of Very High Concern (SVHC)

### RoHS Directive

SCHUNK products are classified as "large-scale stationary installations" or as "large-scale stationary industrial tools" within the meaning of Directive 2011/65/EU and its extension 2015/863/EU "on the restriction of the use of certain hazardous substances in electrical and electronic equipment (RoHS)", or fulfill their intended function only as part of one. Therefore products from SCHUNK do not fall within the scope of the directive at this time.

### REACH Regulation

Products from SCHUNK fully comply with the regulations of Regulation (EC) No. 1907/2006 "concerning the Registration, Evaluation, Authorization and Restriction of Chemicals (REACH)" and its amendment 2022/477. SCHUNK attaches great importance to completely avoiding chemicals of concern to humans and the environment wherever possible.

Only in rare exceptional cases do SCHUNK products contain SVHC substances on the candidate list with a mass content above 0.1%. In accordance with Article. 33 (1) of Regulation (EC) No. 1907/2006, SCHUNK complies with its duty to "communicate information on substances in articles" and lists the components concerned and the substances used in an overview that can be viewed at [schunk.com/SVHC](https://schunk.com/SVHC).

*Signature: see original declaration*

Lauffen/Neckar, October 2024

Dr.-Ing. Manuel Baumeister,  
Head of Systems Engineering,  
Technology & Innovation

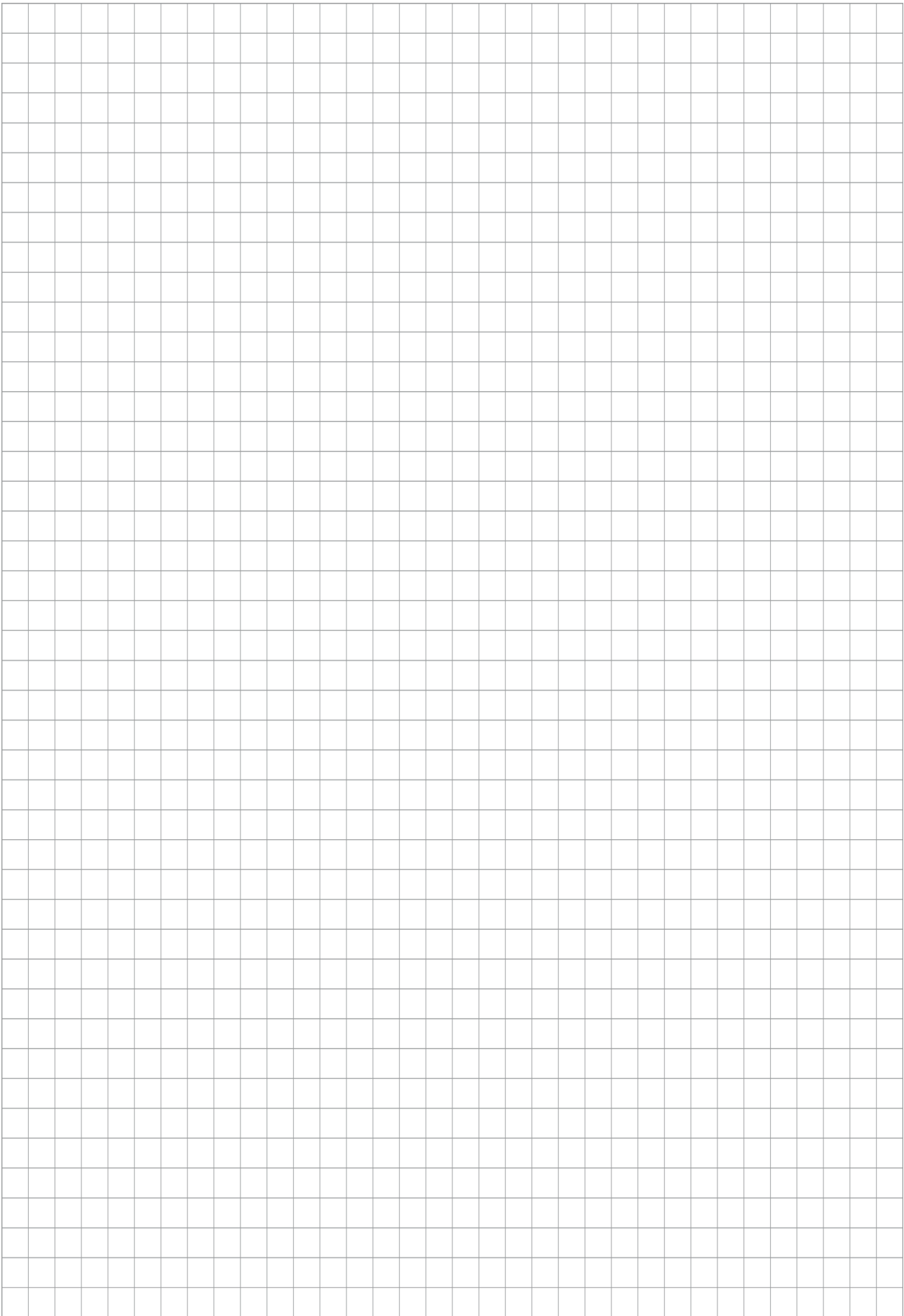

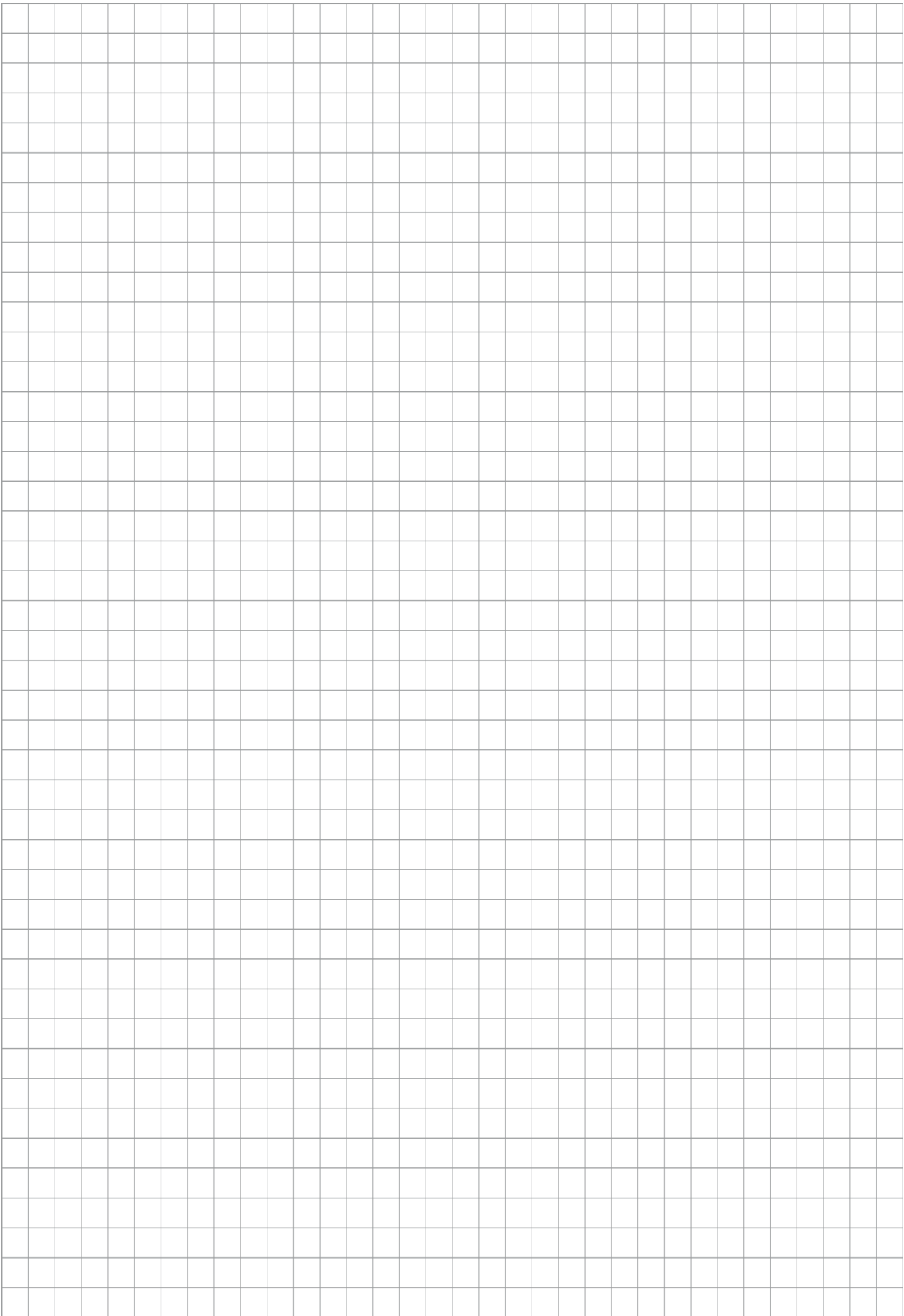



**SCHUNK SE & Co. KG**  
Spanntechnik | Greiftechnik | Automatisierungstechnik

Bahnhofstr. 106 - 134  
D-74348 Lauffen/Neckar  
Tel. +49-7133-103-0  
info@de.schunk.com  
schunk.com

Folgen Sie uns | *Follow us*



Wir drucken nachhaltig | *We print sustainable*