

Original Installation and Maintenance Instructions

Linear unit

HSB-beta®

Type
Beta 165-C-SSF

HSB Automation GmbH
In Laisen 74
D-72766 Reutlingen
Germany
Tel. +49 7121 14498-0
info@HSB-Automation.de
www.HSB-Automation.de

Distributor:
SCHUNK GmbH & Co. KG
Spann- und Greiftechnik
Bahnhofstr. 106 - 134
74348 Lauffen/Neckar
Deutschland
Tel. +49 7133-103-0
Fax +49 7133-103-2399
info@de.schunk.com
www.schunk.com

Table of contents

1	Safety	2
1.1	Symbols used	2
1.2	Intended use	2
1.3	General safety	3
1.4	Use in clean rooms (ISO 14644)	3
1.5	Use in potentially explosive areas	3
1.6	Technical condition of the linear unit	3
1.7	Changes to the linear unit	4
1.8	Requirements for personnel	4
1.9	Responsibilities of the operator	4
2	Warranty	5
3	Technical data – standard design	6
4	Product description	9
5	Transport and storage	10
6	Installation and alignment	11
6.1	Installing the linear unit with mounting brackets	11
6.2	Bolt the linear unit into place from underneath	12
6.3	Setting the maximum stroke	13
6.3.1	Adjusting the position of the inductive limit switches	13
6.3.2	Adjusting the position of the mechanical limit switches	15
6.4	Installing the drive	17
6.4.1	Installing the motor	17
7	Commissioning	19
8	Operation	20
9	Decommissioning	21
10	Maintenance	21
10.1	Lubrication	22
10.2	Replacing the cover band	26
10.3	Your added value in service: Repair and Retrofit	28

1 Safety

These installation and maintenance instructions are part of the unit and must be kept readily available at all times for reference. The instructions must be passed on together with the unit to any third party.

It is important that you contact the manufacturer should there be any part of these Operating Instructions that you do not clearly understand.

1.1 Symbols used

In these Operating Instructions, the following warning symbols and other symbols are used:

DANGER



Indicates immediate danger.
Failure to comply with this instruction risks death or serious injury.

WARNING



Indicates a danger carrying a medium to high risk.
Failure to comply with this instruction may result in death or serious injury.

CAUTION



Indicates a danger carrying low risk.
Failure to comply with this instruction may result in minor or moderate injury or material damage.

Note

Includes tips for the operation and optimum use of the unit.

1.2 Intended use

The mechanical linear unit is designed for installation into machinery and is solely intended for manipulating, positioning, transporting, palletising, loading, unloading, clamping, synchronising, tensioning, testing, measuring, handling and pressing of component parts or tools.

Please take note of the principal fields of application of the linear unit (see Section 4 and Section 3).

In order to guarantee compliance with the law concerning the electromagnetic compatibility of devices (EMC directive), the mechanical linear unit may be used for industrial applications only.

Utilisation of the product for any other purpose would constitute inappropriate use. The manufacturer accepts no liability for any damage resulting from such use. The risk is borne solely by the user.

1.3 General safety

Date of commissioning	<p>The linear unit may be operated only when the machine or installation into which it has been built is found to comply with the following guidelines, laws, regulations and standards:</p> <ul style="list-style-type: none"> • EC/EU directives, • standards regarding the electromagnetic compatibility of units,
Safe operation	<p>For safe operation, please take into account the following documentation:</p> <ul style="list-style-type: none"> • these Operating Instructions for the linear unit, in particular the technical data • the Operating Instructions for the entire installation
Decommissioning	<p>Dispose of the product in accordance with the applicable national requirements. Observe the safety data sheets.</p>

1.4 Use in clean rooms (ISO 14644)

The linear units used in clean rooms are fitted with a vent hole (generally G1/4") at the basic profile.

The following guidelines must be observed:

- The linear unit must be subjected to a negative pressure of 0.2 bar.
The linear unit must be relubricated with a grease suitable for use in clean rooms (basic lubrication carried out using Klübersynth BEM 32-34).

1.5 Use in potentially explosive areas



The linear units are not suitable for use in potentially explosive atmospheres.

1.6 Technical condition of the linear unit

State of the art	<p>The unit conforms to the current state of the art and applicable rules and regulations. The device complies with the EC Machinery Directive and the relevant Harmonised Standards (European standards). Furthermore, the EC Declaration of Incorporation applies.</p>
-------------------------	--

1.7 Changes to the linear unit

Rebuilding and modifying

There are to be no changes, either structural or safety-related, carried out on the linear unit without the prior written agreement of HSB. We accept no liability for any unauthorised changes carried out on the unit.

The operator may carry out only the maintenance and repair work specified in these Operating Instructions. Any further work involving the replacement of wearing or substitute parts may be carried out only following consultation with our service technicians and by the service technicians themselves or by HSB.

Never remove or decommission any safety or protection devices.

Follow the installation instructions supplied by the manufacturer when using special attachment parts.

1.8 Requirements for personnel

Any work involving live parts may be carried out only by trained electricians. This work involves, for example:

- installation of safety limit switches,
- attachment of a drive,
- checking the drive rotation direction.

1.9 Responsibilities of the operator

Preservation of labels The operator must ensure that any lettering, information signs or labels are fully legible (in particular the serial number) and always observed. Any damaged or illegible information signs and labels must be replaced.

Accident Prevention and Environmental Protection The applicable regulations for accident prevention and environmental protection must be observed.

Disposal Dispose of the product according to the relevant national regulations. Refer to the safety data sheets.

2 Warranty

The warranty conditions are specified in the sales documents (delivery and payment conditions). The warranty claim expires if:

- the unit has not been used in accordance with its intended use,
- these Operating Instructions have not been adhered to,
- the unit has been modified without prior authorisation from the manufacturer,
- screws sealed using locking paint have been opened.

The manufacturer is liable only if genuine spare parts have been used during any maintenance or repair work carried out on the unit.

3 Technical data – standard design

Technical data – linear unit Type Beta with spindle drive	Unit size	
	Beta 165-C	
	SSF	
Drive element	KGT	
max. speed [rpm]	3000	
Spindle diameter [mm]	50	
Spindle pitch [mm]	10 20 40	
Moment of inertia [kgm ² /m]	3.57 x 10 ⁻³	
max. speed ¹⁾ [m/s]	1.00	
max. acceleration [m/s ²]	20	
Idle torque [Nm]	4,60	
Maximum stroke (standard) [mm]	5010	
Repeat accuracy [mm]	±0.03	
Operating temperature [°C] (continuous operation)	0 ... 80	
Geometrical moment of inertia I _y [mm ⁴]	24649421	
Geometrical moment of inertia I _z [mm ⁴]	31365033	
Length of standard carriage [mm]	410	
Length of long carriage [mm]	-	
Weight (without stroke) [kg]	42.90	
Weight (per 100 mm stroke) [kg]	4.90	
Weight of standard carriage [kg]	25.20	
Weight of long carriage [kg]	-	
Max. noise emission [dB A] ⁴⁾	80	

¹⁾ dependent on the spindle pitch, at max. speed

²⁾ ball screw

³⁾ trapezoidal screw

⁴⁾ The value changes when assembled with other parts of the system

	Forces and torques for Beta linear unit with spindle drive							
	Dynamic forces [N]				Dynamic torques [Nm]			
Type designation	F_x	F_y	F_z	-F_z	M_x	M_y	M_z	M_{idle}
Beta 165-C-SSF	25000	5000	15000	8000	800	1800	1400	3.20

Values in () refer to the long carriage in each case.

M_{idle} = Idle torque $\pm 30\%$

The specified forces and torques are the respective maximum values for the single load. The individual values must be reduced for a mixed load or the occurrence of several torques or forces at the same time. If in doubt, please contact Technical Support.

Dynamic load ratings of Beta linear unit ball screws

Type and size	Nominal \varnothing in [mm]	Pitch in [mm]	C_{dyn} [N]
Beta 165-C-SSF	50	10	95600
		20	57500
		40	89300

Dynamic load rating for ball screw nut in accordance with DIN 69051, 1989

Dynamic load ratings of Beta linear unit rail guides

Unit size	Size	No. of rails	No. of carriages	Load rating per carriage C_{dyn} [N] THK / Rex*	Preloading F_v [N] THK / Rex*	Guiding distance in direction x (lx1) [mm]	Guiding distance in direction y (ly) [mm]
Beta 165-C-SSF	30L	2	4	43018 / 46000	2151 / 3200	280	128

Values in () refer to the long carriage in each case.

The values for the load rating and the preloading refer to the standard linear guide system

* Rex = Rexroth

Tightening torques [Nm] for fixing screws						
Fixing screws	M4	M5	M6	M8	M10	M12
DIN912/ISO4762-8.8	2,7	5,4	9,0	22,0	43,0	74,0
DIN912/ISO4762-10.9	3,0	5,7	9,0	22,0	43,0	74,0
DIN912/ISO4762-12.9	3,0	5,7	9,0	22,0	43,0	74,0

The figures given are intended as guides.
 For shorter insertion depths, the figures must be adjusted accordingly.

Tightening torques [Nm] for coupling with clamping hub					
Size	14	19	24	28	38
Coupling diameter [mm]	30	40	55	65	80
Screw size	M3	M6	M6	M8	M8
Tightening torque [Nm]	1.34	10.50	10.50	25.00	25.00

Tightening torques [Nm] for coupling with clamping hub					
Size	14	19	24	28	38
Coupling diameter [mm]	30	40	55	65	80
Screw size	M3	M4	M5	M5	M6
Tightening torque [Nm]	1.34	2.90	6.00	6.00	10.00

4 Product description

Linear unit with spindle drive and external rail guide

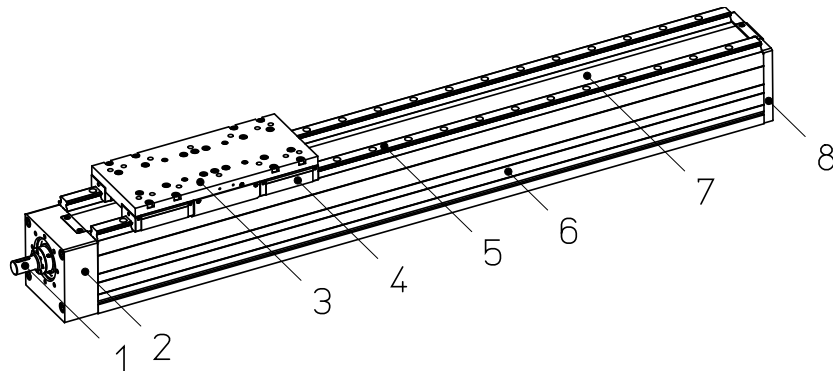

Allg.Ansicht A

Legend	1	Spindle drive	5	Guide rail
	2	Fixed bearing	6	Basic profile
	3	Carriage	7	Cover band
	4	Guide carriage	8	Free bearing

Fig. 1: Sub-assemblies of the linear unit Beta 165-C-SSF with spindle drive

A mechanical linear unit converts rotation into linear motion and thus facilitates fast, safe and accurate movement of loads from one position to another. It consists of a basic aluminium profile, a moveable carriage which is supported by a guide element (here linear guide system) and a drive element (here screw).

Depending on the design, the carriage can absorb forces and torques in all directions and is non-positively connected to the guide and drive element via the drive.

The basic profile is self-supporting up to a certain length and fitted with grooves to keep it in place.

Optionally the linear unit can be fitted with accessories such as a cover, spindle supports, inductive or mechanical limit switches and other built-on parts (see Section 6.3).

The operating area can be flexibly arranged. Several linear units of types Alpha, Beta or Delta can be configured to cover a large area (2 axes) or a spatial arrangement (3 axes).

A plate can be used to connect driven linear units to non-driven linear units of the same type, for example in order to be able to take on large loads.

5 Transport and storage

The mechanical linear unit is a precision instrument. Any heavy impact to this instrument may damage the mechanics and impair its functionality.

CAUTION



Risk of damage by heavy impact or bending!

Transport an assembled linear unit only using transport locks.

In order to avoid any damage to the linear unit when storing or transporting it, the following measures must be taken in order to protect it from jolting or slipping:

- Transport the unit in a sufficiently large container
- Use cushioned packaging

The weight values for the units are listed in Section 3.

The units must be protected against:

- dirt,
- corrosion,
- water
- and aggressive atmospheres.

6 Installation and alignment

The linear unit can be mounted as follows:

- With mounting brackets
- With screws in the sliding blocks
- With screws in the factory-fitted threaded rails

☛ Mount the linear unit only on a flat surface. Standard parallelism <math><0.2\text{ mm}/1000\text{ mm}</math>.

☛ Mounting the linear unit using the threaded rails is recommended for the following situations:
for highly dynamic applications
where the linear unit is attached at only 2 attachment points

6.1 Installing the linear unit with mounting brackets

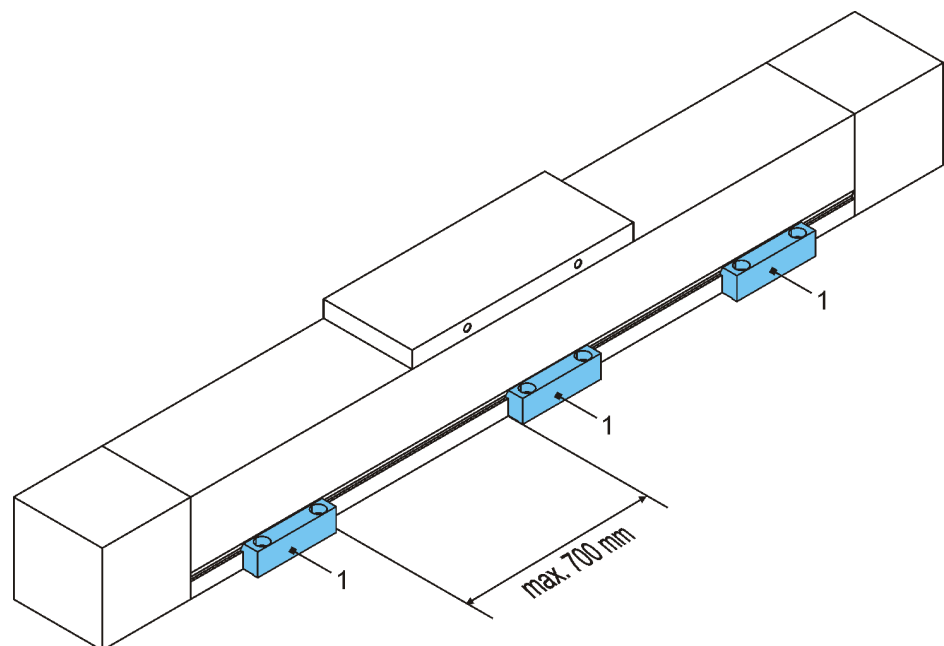

Fig. 2: Mounting brackets (1)

☛ The recommended maximum distance between the mounting brackets is 700 mm.

Proceed as follows

1. Loosely fit the mounting brackets (1) into position (Fig. 2).
2. Align the linear unit axially.
3. Screw the mounting brackets (1) into place (for tightening torques refer to Section 3).

6.2 Bolt the linear unit into place from underneath

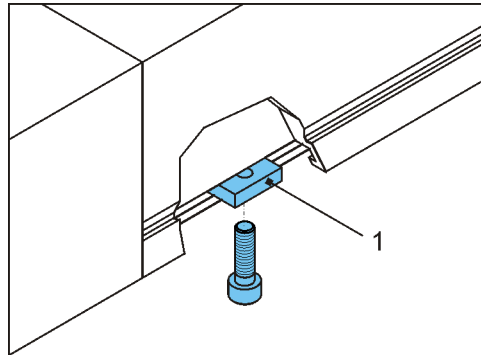

Fig. 3: Sliding blocks (1) in the groove on the underside of the basic profile

Secure the linear unit using fastening bolts from below using the sliding blocks or the threaded rails in the basic aluminium profile (Fig. 3).

Proceed as follows

1. Align the linear unit.
2. Align the sliding blocks (1) / threaded rails.
3. Bolt the linear unit into place
(for tightening torques refer to Section 3).

6.3 Setting the maximum stroke

DANGER



Risk of serious injury from overturning transport devices.
Should the carriage come to a stop beyond the safety area, the transport device mounted on this may break off or overturn. The linear unit can be damaged beyond repair.
Please take note of the specified safety area when setting up the unit and set the limit switches correspondingly.
Electric switches may be connected only by a qualified electrician.

☛ Allow for a sufficient braking distance to ensure that there is enough time to slow down the carriage in the case of an emergency stop.

6.3.1 Adjusting the position of the inductive limit switches

The duty of the inductive limit switches is to shut down the electric drive before the mechanical limit of travel is reached.

The necessary braking distance (ΔB) depends on the speed and deceleration. This braking distance must be less than the distance between the trip point of the limit switch and the actual mechanical limit of travel.

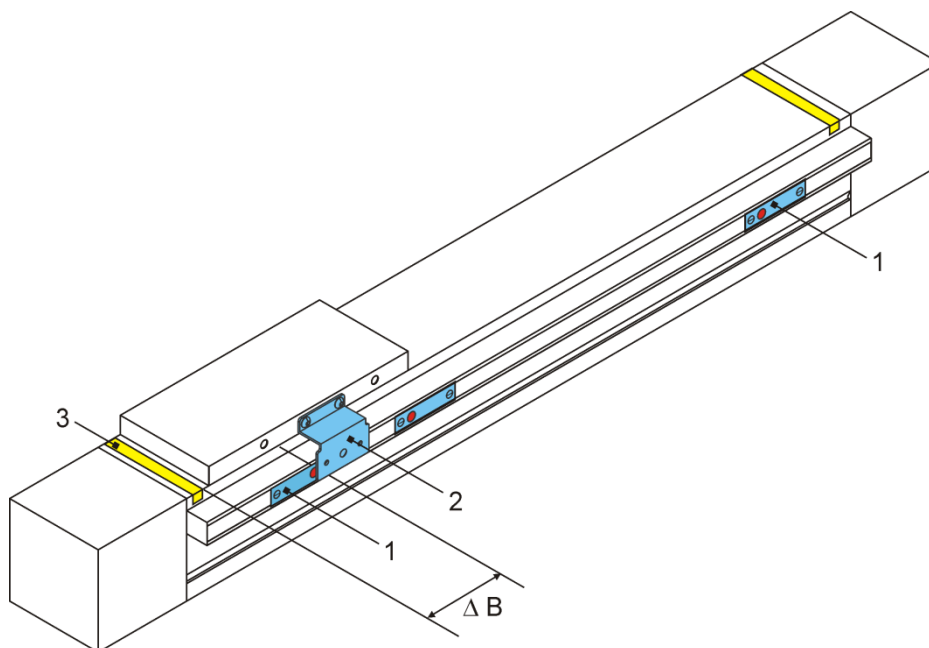

Legend	1	Inductive limit switch
	2	Trip cam
	3	Band marking the safety area

Fig. 4: Inductive limit switches

CAUTION

The limit switches must trip so that the carriage comes to a stop immediately short of the safety area. At delivery, the safety area is marked with a band (3).

Proceed as follows

1. Switch on the power supply for the limit switches.
2. Loosen the fastening screws for the limit switch.
3. Move the carriage up to the braking position.
4. Move the limit switch (NC) far enough under the switching cam for it to trip and the LED on the sensor to go out.
5. Move the carriage away.
6. Tighten the limit switch fastening screws.
7. Check the correct position of the limit switch: Move the carriage along by hand and check the switch tripping point.
8. Fit the limit switch bar cover.

6.3.2 Adjusting the position of the mechanical limit switches

Mechanical safety limit switches (NC) must be used if there is a risk that persons may be endangered unless the electric drive shuts down immediately.

The drive may be started up only once all limit switches are correctly set and are closed.

Mechanical safety limit switches may be combined with inductive limit switches.

External dampers must be fitted as protection against mechanical damage.

The necessary braking distance (ΔB) depends on the speed and deceleration. This braking distance must be less than the distance between the trip point of the limit switch and the actual mechanical limit of travel (Fig. 5).

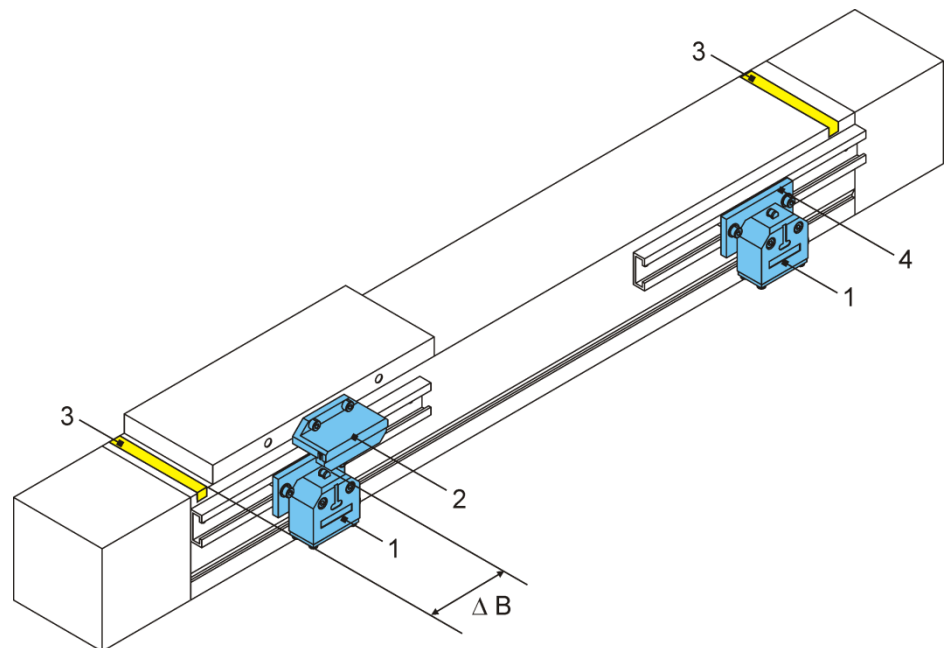

Legend	1	Mechanical limit switches
	2	Trip cam
	3	Band marking the safety area
	4	Retaining plate
	B	Braking distance

Fig. 5: Mechanical limit switches

CAUTION

The limit switches must trip so that the carriage comes to a stop immediately short of the safety area. At delivery, the safety area is marked with a band (3).

Proceed as follows

1. Switch on the power supply for the limit switches.
2. Loosen the clamping screw for the retaining plate (Fig. 5).
3. Move the carriage up to the safety area.
4. Push the limit switch along until it trips.
5. Tighten the clamping screw on the retaining plate.
6. Check the correct position of the limit switch: Move the carriage along by hand and check the switch tripping point.
If this leaves insufficient braking distance, repeat the adjustment process.

6.4 Installing the drive

Make sure that the direction of rotation of the external drive corresponds to the direction of rotation of the spindle or the toothed belt, so that the limit switches operate correctly.

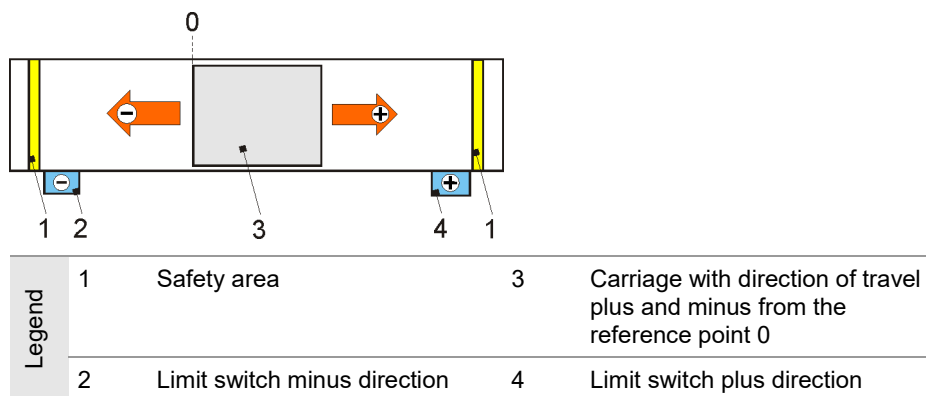

Fig. 6: Example of direction of travel and limit switch circuits

6.4.1 Installing the motor

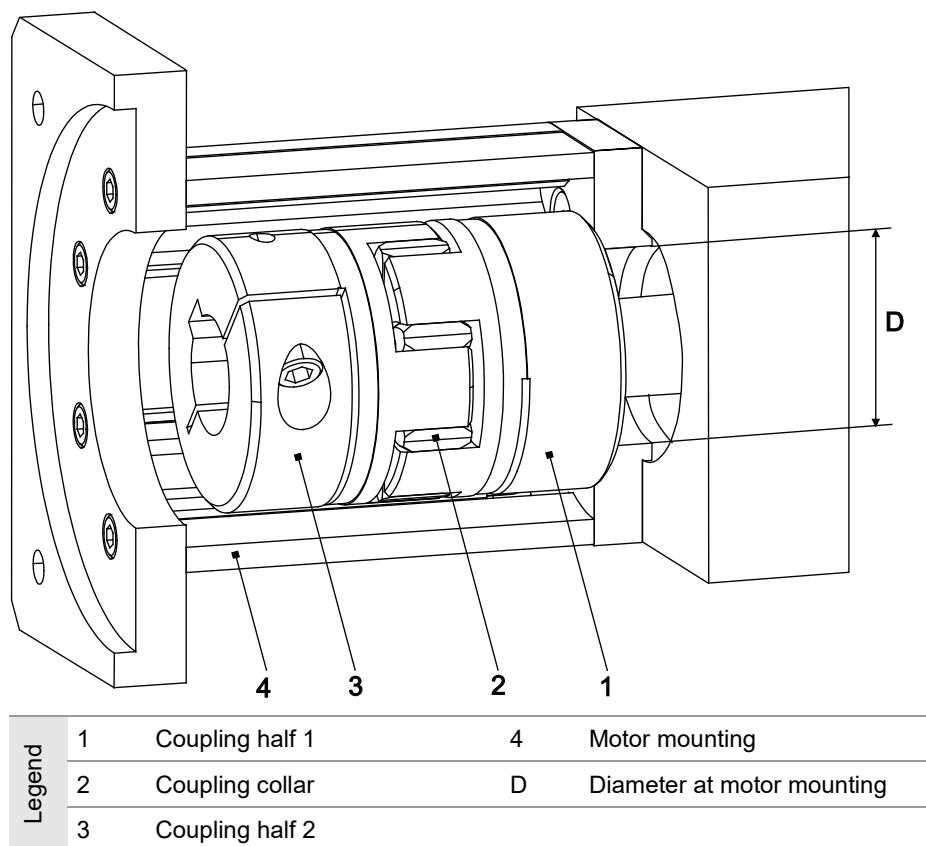

Figure 7: Motor mounting with motor coupling at drive journal

Proceed as follows

1. Place the motor and the coupling elements in the mounting position alongside the linear unit.
2. Check the direction of rotation of the motor. It must correspond to the safety limit switches (Fig. 6). Change the direction of rotation of the motor if required.
3. If the coupling diameter is smaller than the D measurement at the motor mounting (4), first mount the coupling half 1 (1) (bore flush with the drive shaft) and then the motor mounting (4) (Figure 7).

If the coupling diameter is larger than the D measurement at the motor mounting (4), first mount the motor mounting (4) and then the coupling half 1 (1) (bore flush with the drive shaft). Tighten the coupling clamping screw using the mounting bore at the motor mounting (4).

4. If necessary, push the coupling collar (2) on to the coupling.
5. Fix the coupling half 2 (3) to the motor journal.
6. Attach the motor to the motor mounting.

Tightening torque [Nm] of clamping screws

Screw	SW	Torque
M6	5	14
M8	6	35
M10	8	65
M12	10	74

7 Commissioning

WARNING



Risk of injury or damage to other installation parts due to quick linear movements of the transport devices due to centrifugal load.
Only authorised personnel are permitted to commission the linear unit.

DANGER



Risk of crushing due to incorrect direction of movement of the transport device.
Should the direction of rotation of the drive (motor or gearbox) and the carriage drive (spindle or toothed belt) not correspond, the mounted transport device may travel in the wrong direction. Around all rotating parts, e.g. GX shaft and around the toothed belt (when used without cover band), there is a risk of being pulled in, and of clothing or body parts being caught up and trapped. There is also a risk of crushing around the moving carriage. These hazards can be countered by installing effective safety mechanisms that comply with the current standards and are state-of-the-art. These are not supplied with the linear unit and must be installed by the manufacturer of the overall installation.
Use of the deflection belt drive without the protective hood supplied is not permitted.
Only qualified electricians are permitted to carry out any work on the electrical installation or check the direction of rotation.

Checking the unit before commissioning

Before commissioning, the following must be checked:

- whether the holding devices used are consistent with the mass and acceleration information provided by the manufacturer,
- whether the machine or installation in which the linear unit is installed corresponds to the provisions set out by the machinery directive, the harmonised standards, the European standards or the national standards,
- whether the linear unit is correctly mounted,
- whether the inductive and/or mechanical limit switches are correctly connected and functioning properly,
- whether the direction of rotation of the motor shaft and, if applicable, the intermediary gearbox corresponds to the direction of rotation of the spindle or the toothed belt.

If there are faults detected during this inspection, commissioning is not permitted.

Test run

To prevent accidents, collisions and possible errors in the programming, move the linear unit along the stroke several times at such a low speed that it can be stopped in good time in case of an emergency.

The installation can be started up only after it has been ensured that there is no risk of a collision as a result of exceeding the maximum stroke.

8 Operation

WARNING



The drive motor can heat up considerably during operation. In this case, refer to the operating instructions supplied for the drive motor.

CAUTION



Risk of damage due to harmful environmental influences! The linear unit may be operated only under ambient conditions which are permitted by the manufacturer.

Ambient conditions

The linear unit may only be operated within the permitted temperature range of 0 - 80 °C.

Operating the unit in damp, abrasive conditions may result in foreign objects entering components in the linear unit. To prevent this, as part of the integration of the linear unit into the entire plant, measures may need to be taken to prevent foreign bodies from penetrating, e.g. using folding plates, baffle plates, sealing air.

Required inspection

The linear unit must be occasionally checked during operation to see that it is functioning correctly.

The personnel responsible must check the linear unit and the machinery for any visible signs of damage or defects at least once during each shift.

Should there be any changes observed which may compromise safety, the unit must be switched off immediately.

Emergency stop

The maximum permissible load values must not be exceeded even in an emergency stop situation.

As a rule, the category 1 emergency stop strategy (targeted braking to standstill, then de-energise) is chosen for automation equipment with moving masses. A simple emergency stop strategy is not usually effective, as the masses are still moving and can cause damage.

End position damping

The end stops and stop buffers installed in our linear modules protect the unit at low speed (commissioning). They are definitely not intended to completely protect the unit against damage at high speed and/or with a large mass.

9 Decommissioning

WARNING



Risk of injury or damage to other installation parts due to falling parts.

Only authorised personnel are permitted to deinstall the linear unit.

1. Separate the machine/installation from the mains supply.
2. Disassemble the drive from the linear unit.
3. Unscrew the linear unit from the machine/installation.

10 Maintenance

DANGER



Around all rotating parts, e.g. the GX shaft, there is a risk of being pulled in, and of clothing or body parts being caught up and trapped. There is also a risk of crushing around the moving carriage.

For this reason, lubrication of the linear unit may be carried out only while it is moving slowly (max. 0.025 m/s), and for any cleaning work the linear unit drive must be shut down and secured against being restarted.

- All mounted ball bearings are sealed and maintenance-free.
- Remove excessive dust and dirt from the cover band and other parts of the linear unit regularly.
- Regularly re-lubricate the screw of the linear axes.

10.1 Lubrication

Influencing factors The following influencing factors are important for an accurate regulation of lubrication intervals:

- Load
- Speed
- Motion sequence
- Operating temperature
- Degree of contamination

Short lubrication intervals Short lubrication intervals are required for:

- operation under the influence of dust and dampness
- a heavy load
- high speed (up to V_{max})

Short strokes
 (Short stroke design) Short stroke refers to a stroke with a value equal to or lower than that specified in the table. To achieve the best possible lubrication, relubrication should be carried out from both sides with guiding carriage short strokes and thus requires a special attachment. (Design feasibility must be checked.)

A lubrication stroke should also be carried out at least once per shift (8 hours) where possible.

Größe	12	15	20	25	25L	30	30L	35	35L
THK	40	95	120	140	175	160	210	185	250
Bosch-Rex.	40	80	100	115	160	135	180	155	210
Lubrication stroke	70	130	160	180	220	210	260	240	300

In addition, it must be ensured that the stroke is at least (2x) the length of the ball screw nut. If this is not the case, consultation is mandatory.

Initial lubrication

☛ After commissioning, carry out the initial lubrication. The basic lubrication has already been carried out by the manufacturer.

Refer to the lubrication regulations on the following pages.

Note

Under normal operating conditions (dry environment, no dusts, etc.), the roller guide is lubricated for life with integrated lubricating felts.

Lubrication points on the linear unit

(Version lubrication via carriage plate)

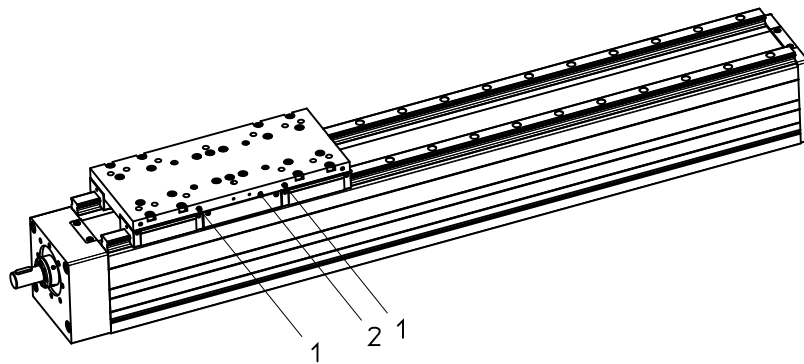

Fig. 8: Possible lubrication points (1 and 2) on the carriage

The lubrication points are located on the moveable carriage of the linear unit (both sides), on the side of the guide carriage each for the carriage (1 or 2) and for the ball screw drive (3).

Lubrication points on the linear unit

(Version lubrication on guiding carriage)

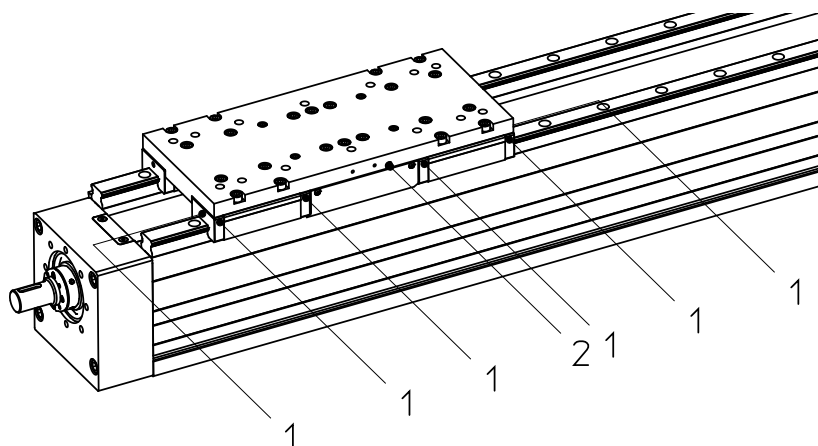

Fig. 9: Possible lubrication points (1 and 2) on the carriage

The lubrication points are located on the moveable carriage of the linear unit (both sides), directly on the guide carriage (1) of the rail guides and at the side of the carriage plate for the ball screw (2).

Lubrication method

Lubrication should take place as far as possible while in motion so that the grease is distributed and no pressure builds up.

Lubrication plan for the ball screw

KGT* type	Lubrication intervals by number of overrollings	Amount of grease [cm ³] per ball screw nut	Type of grease
5010	15,000,000**	25.90	Grease in accordance with DIN 51825-KP2N-20, e.g. Klüberplex BE 31-102
5020		26.50	
5040		27,20	
			<ul style="list-style-type: none"> ☛ If a different type of grease is used, please comply with the instructions provided by the lubricant manufacturer! ☛ Greases with a solid lubricant proportion (e.g. graphite, MoS₂) are not to be used!
<p>*KGT = ball screw</p> <p>**or at least twice a year. The lubrication interval depends on the ambient conditions and the load (see Fig. 11). Relubrication "in motion"!</p>			

Lubrication plan for the rail guide

Guide carriage size	Lubrication interval	Amount of grease [cm ³] per guide carriage	Type of grease
30L with ball chain	approx. 5,000 km*	approx. 2.0	Grease in accordance with DIN 51825-KPE1R-20, e.g. Klüberplex BE 31-102
30L without ball chain	approx. 2,000 km	approx. 4.4	
			<ul style="list-style-type: none"> ☛ If a different type of grease is used, please comply with the instructions provided by the lubricant manufacturer! ☛ Grease with a solid lubricant component (e.g. graphite, MoS₂) must not be used!

**or at least twice a year. The lubrication interval depends on the ambient conditions and the load. Relubrication "in motion"!*

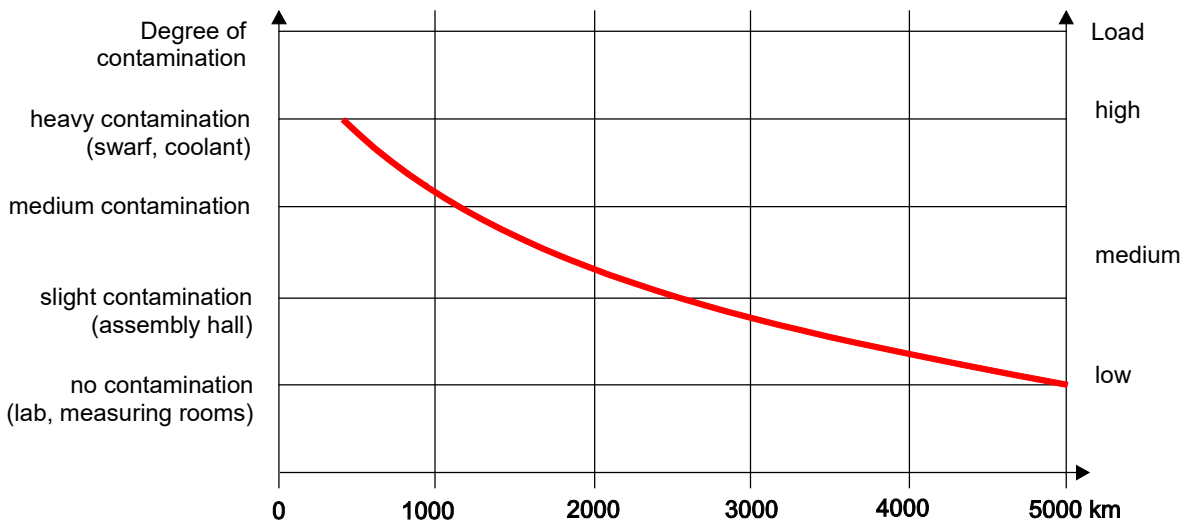
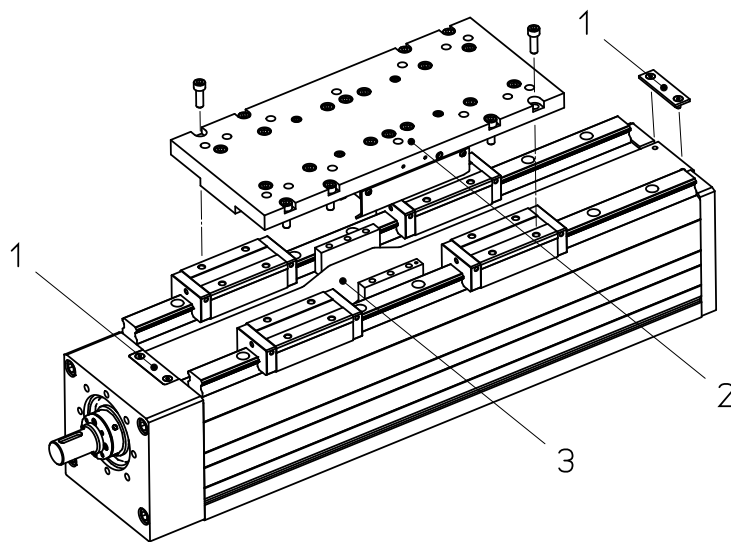

Fig. 10: Relubrication intervals for the linear guide system with ball chain

10.2 Replacing the cover band

- ☛ For optimum functioning of the linear unit and to prevent damage during operation, it must be ensured during installation that no foreign bodies enter the basic profile or other parts of the linear unit.
- ☛ Do not damage the standard parts (screws, pins, etc.) or the parts that are removed, as they will be used again.
- ☛ If the cover bands are worn, replace the band guide elements also. If the cover bands are damaged, check the band guide elements for wear and replace them only if necessary.



Legend	1	Clamping plate
	2	Carriage (plate)
	3	Cover band

Fig. 11: Cover band of the linear unit Beta 165-C-SSF

- Proceed as follows**
1. Move the carriage into the middle. The unscrew the carriage plate and list it off.

Note! Do not rotate the carriage plate. It must be refitted in the same position.

Do not lose the O-rings from the lubrication ports on the inside of the carriage.

2. Undo the clamping plates (1) from the ends of the cover band (3) and take off the cover band.
3. Undo the clamping plates from the ends of the cover band and lift the cover band off upwards.
4. Check the band guide elements such as the pressure rollers (a) and lift-off rollers (b) for wear.

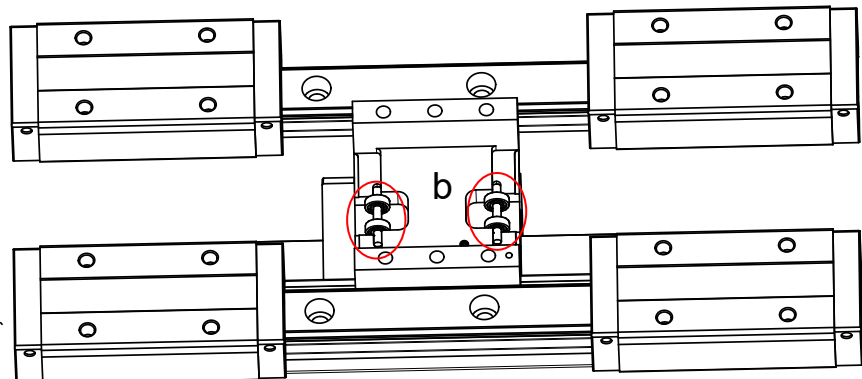
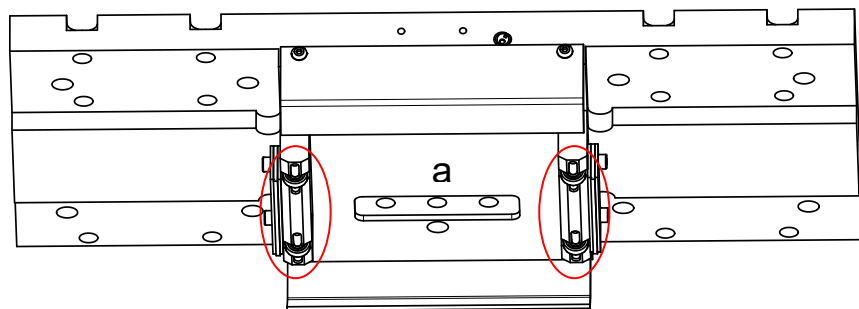

- If the cover band is worn, it is essential the band guide elements are also replaced. Worn guide elements would damage the new cover band.
- If the cover band is worn, it is essential the band guide elements are also replaced. Worn guide elements would damage the new cover band.

5. Insert the new cover band with the broad side (the cut edge is oblique) facing downwards, and clamp it at one end by screwing the clamping plate into place
6. Carefully push the cover band into its guide along its entire length so that it audibly clicks home. It must not stick up at any point or else it will become damaged.
7. Tension the cover band and clamp it at the other end by screwing the clamping plate into place
8. Make sure that the O-rings are located in the lubrication ports on the underside of the carriage, and screw the carriage back on in the correct position.
9. To check that the installation is correct, move the carriage slowly from one end of the linear unit to the other, checking that the cover band remains in position at all times.

10.3 Your added value in service: Repair and Retrofit

In addition to installation and maintenance, we also offer professional repair and retrofit services for our products. You benefit from our expertise, fast fault diagnosis, and expert repairs – helping to extend the service life of your products and modernize existing systems.

For further information regarding repairs or retrofit solutions, please contact our customer service at service.greifsysteme@de.schunk.com.

We will be happy to advise you.