

1 User information

1.1 Purpose of document

These instructions are an integral part of the product supplied and contain important information for the safe installation, commissioning, operation, servicing, and maintenance.

These instructions must be read before using the product and must be observed during operation, in particular the «General safety instructions section».

1.2 Illustration of safety features

DANGER	
	Indicates imminent danger. If the information is ignored, death or serious injury (permanent disability) will result.
WARNING	
	Indicates a potentially dangerous situation. If the information is ignored, it is possible that death or serious injury (permanent disability) will result.
WARNING	
	Indicates a potentially dangerous situation. If the information is ignored, it is possible that material damage and light to medium injury will result.
NOTE	
	Indicates general information, useful tips for users and work recommendations which do not impact on the health and safety of operators. ... underscores useful tips and recommendations as well as information for efficient and trouble-free operation.
CAUTION	
	Indicates a potentially dangerous situation. If the information is ignored, material damage will result. ... points out a potentially dangerous situation that can lead to material damage if it is not avoided.

2 General safety instructions

2.1 Intended use

The clamping device may only be used in accordance with the technical data and has been designed for stationary application on milling machines in an industrial environment. Using the device in accordance with the intended purpose includes compliance with the commissioning, installation, and operating instructions, and with the environmental and service conditions as provided by the manufacturer. The manufacturer accepts no liability for damage resulting from non-intended use.

2.1.1 Technical Data

max. torque	Pull-down force with four clamping pins
30 Nm	15 kN

Exceeding the max. torque results in damage to the clamping mechanism.

2.2 Reasonably foreseeable misapplication

Any application that is not in accordance with the "Intended use" or exceeds such intended use is considered not in accordance with the regulations, and is forbidden.

Any other use of the device is subject to confirmation from the manufacturer.

Examples of foreseeable misapplication

- Clamping device used on rotating systems.
- Clamping widely protruding workpieces.
- Clamping workpieces with a weight of over 5 kg in vertical position without an additional protection against the workpiece falling out as a protective measure for the operator.

2.2.1 Alterations and modifications

In the case of unauthorised alterations and modifications of the clamping device, the manufacturer's liability ceases and any warranty is voided.

2.2.2 Spare and wear parts and auxiliary material

Only use original parts or parts approved by the manufacturer.

Using spare and wear parts by third party manufacturers may lead to risk.

2.3 Residual risk

The user is responsible for applying the correct workpiece clamping.

New clampings have to be carefully checked by qualified personnel with relevant training.

One always needs to allow for the risk that the workpiece may slip or be dislodged, even when the clamping device is functioning correctly. This is due to the different geometries to be clamped, contact surfaces, clamping friction values, processing force, wrong manipulation of the milling machine etc.

Protective devices are to be attached to the processing machine that will protect the operator from any tool or workpiece parts that may be ejected.

It is mandatory that operators and others in the proximity of the processing machine wear protective goggles.

Do not use methods of operation that impair the function and operational safety.

2.3.1 Replacing the clamping pins

Insufficiently tightened clamping pins can lead to damage.

2.3.2 Notes on clamping technology

The operator is responsible for ensuring that the clamping geometry and clamping forces are suitable for the intended processing. We recommend that clamping be carried out with a torque wrench in order to achieve consistent clamping results. The pull-down forces can only be achieved if the set-up system functions correctly. Regular servicing and cleaning in accordance with the operating instructions is mandatory in order to ensure correct function.

2.4 Duties of the organisation in charge

The organisation in charge of the device undertakes to only allow operatives to work on the device:

- who are familiar with the basic health and safety regulations and regulations for the prevention of accidents.
- who have completed appropriate induction for working with the machine.
- who have read and understood these operating instructions.

The requirements of the EC Directive 2007/30/EC on the use of work machinery must be complied with.

2.5 Operator duties

All persons who have been instructed to work with the machine undertake to:

- observe the basic regulations for health and safety and for the prevention of accidents.
- read and understand the section on safety and the safety instructions in these operating instructions prior to working with the machine, and to observe these instructions.

2.6 Operator qualification

The installation, initial setup, fault analysis and periodic monitoring must be carried out by competent personnel with the relevant qualifications.

2.7 Personal protective equipment

WARNING	
	Ejected hot fragments can lead to serious eye injury. The regulations for safety at work and the prevention of accidents always have to be observed when working with the machine. Personal protection equipment must be worn at all times, in particular safety boots, gloves and safety goggles.

2.8 Warranty

Warranty	24 months
Maximum service life	50'000 clamping cycles

The warranty period is valid from the date of delivery ex-works, provided the machine is used as intended and subject to the following conditions:

- Compliance with concurrent documents.
- Compliance with environmental and operating conditions.
- Compliance with the specified maintenance and lubrication intervals.
- Observance of the maximum service life.

Parts in contact with workpieces are not covered by the warranty.

3 Description

The GFD mini products are plate consoles, pyramids and tombstones made of hard-anodised aluminium with hardened bushes or long-term nitrided steel base bodies. The integrated set-up system is suitable for the KSC mini 70-80, KSC mini 70-100, KSC3 80-130, KSC3-K 80-130, KSC3 125-160 and KSC3-K 125-235, KSC3-K 125-160 and KSC3-K 125-235 clamping devices as well as for direct workpiece loading. Depending on the vise size, the 52 or 96 mm pitch is required.

The vise or workpiece to be clamped is positioned via the four clamping pins and pulled down onto the base surface.

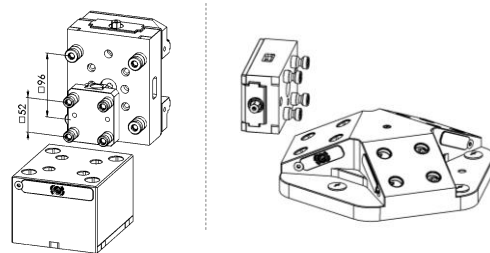

When attaching the clamping pins directly into a workpiece to be machined, make sure that the flatness of the contact surface is ≤ 0.05 mm.

4 Function

By activating the clamping screw (pos. 40) with approx. four turns, the slides (pos. 20 and 30) as well as the clamping rods (pos. 50) are pressed onto the lower conical surface on the clamping pin. The clamping pins are pressed into the half-shell shape and the component to be clamped is pulled down onto the set-up system.

Attention:

If not cleaned properly, the set-up system can be damaged by chips being pressed in.

5 Sealing plugs

To reduce the cleaning effort, sealing plugs are available as accessories for both pitch. When using the combination module in the 96 pitch, the 52 pitch should not be sealed.

The sealing plugs can be easily removed with the magnet removal aid.

6 Clamping pins and interface

Tightening torque for $\varnothing 16$ clamping pin with thread M8 and pitch 52 mm $\rightarrow 20$ Nm

Tightening torque for $\varnothing 20$ clamping pin with thread M10 and pitch 96 mm $\rightarrow 20$ Nm

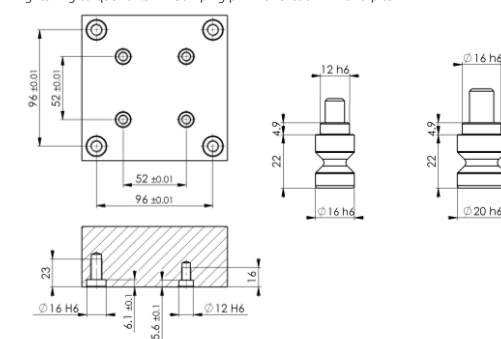

7 Operation

7.1 Aligning / Fastening

The plates are fastened with two M12 cylinder screws and a tightening torque of 70 Nm. Alignment with two cylinder pins $\varnothing 12m6$ or alternatively with fitting screws or alignment and centering sets width 12, 14, 16 or 18 mm.

The position of the panels can be checked at the milled reference points.

7.2 Covering the fastening screws

Plastic covers to cover the screws are available as accessories.

The covers can be pressed in by hand.

To remove the cover must be drilled a hole in the centre (approx. $\varnothing 3mm$), destroyed and removed with a screwdriver.

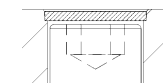

7.3 5-axis height extension

The 5-axis height extension have interfaces at the base for GFD mini, GFD and VERO-S clamping pin.

8 Servicing, cleaning and maintenance

Before clamping any components with the set-up system, it is important to ensure that no fragments or other foreign bodies are in the system. This applies in particular to the locating hole for the clamping pin and the contact surface, which must be clean.

Cleaning / Lubrication

Clean the support and bearing surfaces.

Lubricate the mechanical clamping elements on a regular basis.

9 Removing

- Remove countersunk screws. (pos. 70)
- Remove clamping screw. (pos. 40)
- Remove front (pos. 20) and rear (pos. 30) slider.
- Dismantle pressure springs. (pos. 60)
- Push out clamping rods (pos. 50) sideways.
- Clean individual parts and check for damage.
- Lubricate threads and bores with Molykote grease.

10 Assembly

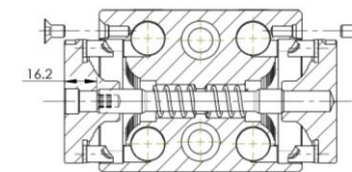

Module 52

Turn the clamping screw (pos. 40) into the front slider until the dimension 16.2 mm is reached, then screw in the rear slider.

Module 96 or combi module

Turn the clamping screw (pos. 40) into both sliders at the same time without any offset. The disassembling steps are performed in reverse order to assemble.

11 Troubleshooting / Eliminating faults

Clean the support and bearing surfaces.

Clamping spindle is difficult to move

Disassemble, clean and lubricate.

Clamping pin is stuck

Open clamping screw (pos. 40) as soon as one slider runs to the stop, the second slider will be released.

12 Assembly drawing

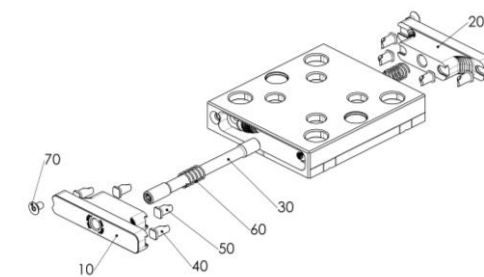

12.1 Parts list

Pos.	Designation	Quantity
10	Front slider	1
20	Rear slider	1
30	Clamping screw	1
40	Clamping rod 96x96	4
50	Clamping rod 52x52	4
60	Pressure spring 1.5x14x29	2
70	Countersunk screw M6x10, 10.9	2

13 Taking out of service

The clamping device and all accessories can be disposed of as scrap metal without any risk.

For further data, please see homepage >> schunk.com <<

H.-D. Schunk GmbH & Co.
Spanntechnik KG
Lothringer Strasse 23
D-88512 Mengen

Tel: +49-7572-7614-1300
Fax: +49-7572-7614-1099

CMM@de.schunk.com
schunk.com