

# Montage- und Betriebsanleitung Installation- and operating instruction

## Mechanisches Rüstsystem Mechanical set-up system

### GFD



H.-D. SCHUNK GmbH & Co.  
Spanntechnik KG  
Lothringer Strasse 23  
D-88512 Mengen

## Table of contents:





<b>1</b>	<b>User information</b> .....	<b>18</b>
1.1	Purpose of document, validity .....	18
1.2	Illustration of safety instructions .....	18
<b>2</b>	<b>General safety instructions</b> .....	<b>19</b>
2.1	Intended use .....	19
2.1.1	Technical data .....	19
2.2	Reasonably foreseeable misapplication .....	19
2.2.1	Alterations and modifications.....	19
2.2.2	Spare and wear parts and auxiliary material.....	19
2.3	Residual risk .....	20
2.3.1	Replacing the clamping pins.....	20
2.3.2	Notes on clamping technology.....	20
2.4	Duties of the organisation in charge.....	20
2.5	Operator duties.....	20
2.6	Operator qualification .....	21
2.7	Personal protective equipment.....	21
2.8	Warranty .....	21
<b>3</b>	<b>Description</b> .....	<b>22</b>
3.1	Function.....	23
<b>4</b>	<b>Operation</b> .....	<b>24</b>
4.1	Aligning / Fastening .....	24
4.1.1	Fastening on machine table .....	24
4.1.2	Aligning a GFD set-up station without centring pin and positioning pin.....	24
4.1.3	Alignment with several GFD set-up stations.....	25
<b>5</b>	<b>Covers</b> .....	<b>26</b>
5.1	Closing plugs for unused locating holes .....	26
5.2	Closing plug for unused grid holes .....	26
<b>6</b>	<b>Clamping pin and interface</b> .....	<b>27</b>
<b>7</b>	<b>Servicing, cleaning and maintenance</b> .....	<b>28</b>
7.1	Cleaning / Lubrication .....	28
<b>8</b>	<b>Troubleshooting / Eliminating faults</b> .....	<b>30</b>
8.1	Clamping screw is not moving freely.....	30
8.2	Clamping slide seized up.....	30
<b>9</b>	<b>Assembly drawing</b> .....	<b>31</b>
<b>10</b>	<b>Taking out of service</b> .....	<b>31</b>

# 1 User information

## 1.1 Purpose of document, validity

These instructions are an integral part of the product supplied and contain important information for the safe installation, commissioning, operation, servicing and maintenance. These instructions must be read before using the product and must be observed during operation, in particular the "General safety instructions" section.

## 1.2 Illustration of safety instructions

DANGER	
	<p>Indicates imminent danger. If the information is ignored, death or serious injury (permanent disability) will result.</p>
WARNING	
	<p>Indicates a potentially dangerous situation. If the information is ignored, it is possible that death or serious injury (permanent disability) will result.</p>
WARNING	
	<p>Indicates a potentially dangerous situation. If the information is ignored, it is possible that material damage and light to medium injury will result.</p>
NOTE	
	<p>Indicates general information, useful tips for users and work recommendations which do not impact on the health and safety of operators.  ... underscores useful tips and recommendations as well as information for efficient and trouble-free operation.</p>
CAUTION	
	<p>Indicates a potentially dangerous situation. If the information is ignored, material damage will result.  ... points out a potentially dangerous situation that can lead to material damage if it is not avoided.</p>

## 2 General safety instructions

### 2.1 Intended use

The set-up system may only be used in accordance with the technical data and has been designed for stationary application on milling machines in an industrial environment.

Using the device in accordance with the intended purpose includes compliance with the commissioning, installation and operating instructions, and with the environmental and service conditions as provided by the manufacturer.

The manufacturer accepts no liability for damage resulting from non-intended use.

#### 2.1.1 Technical data

Version	max. torque	max. pull-down force per clamping point
GFD	30 Nm	20 kN

Exceeding the max. torque results in damage to the clamping mechanism.



#### Weight:

GFD-NSL-4 400 x 330: 27.3 kg

GFD-NSL-6 400 x 400: 32.3 kg

GFD-NSL-6 400 x 530: 44.4 kg

GFD-NSL-10 497 x 532: 53.2 kg

For further data, please see homepage >> [schunk.com](https://www.schunk.com) <<

### 2.2 Reasonably foreseeable misapplication

Any application that is not in accordance with the "Intended use" or exceeds such intended use is considered not in accordance with the regulations, and is forbidden. Any other use is subject to confirmation from the manufacturer.



#### Examples of foreseeable misapplication

- Clamping device used on rotating systems.
- Clamping widely protruding workpieces.
- Clamping workpieces with a weight of over 20 kg in vertical position without an additional protection against the workpiece falling out as a protective measure for the operator.

#### 2.2.1 Alterations and modifications

In the case of unauthorised alterations and modifications of the clamping device, the manufacturer's liability ceases and any warranty is voided.

#### 2.2.2 Spare and wear parts and auxiliary material

Only use original parts or parts approved by the manufacturer.

Using spare and wear parts by third party manufacturers may lead to risk.

## 2.3 Residual risk

The user is responsible for applying the correct workpiece clamping. New clampings have to be carefully checked by qualified personnel with relevant training. One always needs to allow for the risk that the workpiece may slip or be dislodged, even when the set-up system is functioning correctly. This is due to the different geometries to be clamped, contact surfaces, clamping friction values, processing force, wrong manipulation of the milling machine etc.

Protective devices are to be attached to the processing machine that will protect the operator from any tool or workpiece parts that may be ejected.

It is mandatory that operators and others in the proximity of the processing machine wear protective goggles.

Do not use methods of operation that impair the function and operational safety.



### 2.3.1 Replacing the clamping pins

Damage may result if clamping pins are insufficiently tightened.



### 2.3.2 Notes on clamping technology

The operator is responsible for ensuring that the clamping geometry and clamping forces are suitable for the intended processing.

We recommend that clamping be carried out with a torque wrench in order to achieve consistent clamping results.

The pull-down forces can only be achieved if the set-up system functions correctly.

Regular servicing and cleaning in accordance with the operating instructions is mandatory in order to ensure correct function.

## 2.4 Duties of the organisation in charge

The organisation in charge of the device undertakes to only allow operatives to work on the device:

- who are familiar with the basic health and safety regulations and regulations for the prevention of accidents.
- who have completed appropriate induction for working with the machine.
- who have read and understood these operating instructions.

The requirements of the EC Directive 2007/30/EC on the use of work machinery must be complied with.

## 2.5 Operator duties

All persons who have been instructed to work with the machine undertake to:

- observe the basic regulations for health and safety and for the prevention of accidents.
- read and understand the section on safety and the safety instructions in these operating instructions prior to working with the machine, and to observe these instructions.

## 2.6 Operator qualification

The installation, initial setup, fault analysis and periodic monitoring have to be carried out by competent personnel with the relevant qualifications.

## 2.7 Personal protective equipment

<b>WARNING</b>	
	<p><b>Ejected hot fragments can lead to serious eye injury. The regulations for safety at work and the prevention of accidents always have to be observed when working with the machine.</b></p> <p><b>Personal protection equipment must be worn at all times, in particular safety boots, gloves and safety goggles.</b></p>

## 2.8 Warranty

Warranty	24 months
Maximum service life	50'000 clamping cycles

The warranty period is valid from the date of delivery ex-works, provided the machine is used as intended and subject to the following conditions:

- Compliance with the concurrent documents.
- Observance of environmental and work conditions.
- Observance of the specified servicing and lubrication intervals.
- Observance of the maximum service life.

Parts in contact with the workpiece are not covered by the warranty.

### 3 Description

The GFD set-up stations have been designed for stationary installation on machine tables of vertical or horizontal machining centres.

The locating holes for the clamping pin are made in a unique half shell shape and this makes it possible to clamp the components quickly and truly aligned.

The GFD-NSL-6 400 x 400 set-up station is used as the principle representation.

#### The following components can be clamped

Machine vices, single or multiple pallets and unprocessed parts.

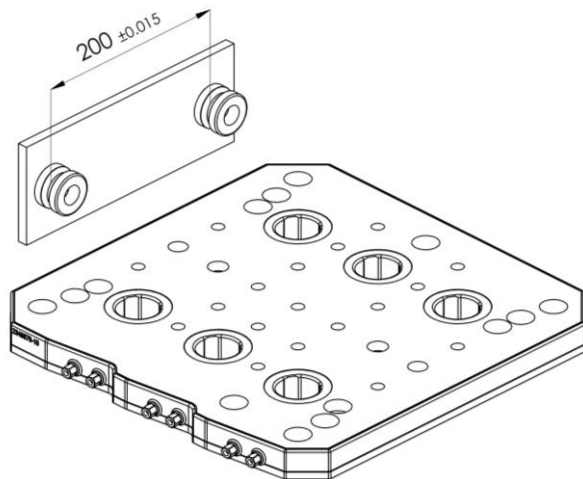

#### Standard application using clamping pins

Fit two or several GFD clamping pins with a distance of 200 mm into the components to be clamped.

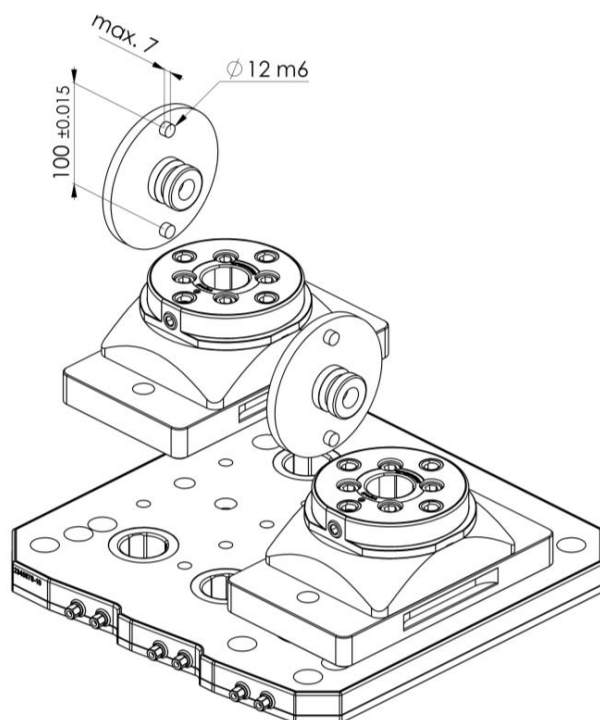

#### Single pallet fitting with GFD console

1 pc. GFD console round

1 pc. clamping pin

2 pcs. Ø12 m6 indexing pins fitted in the component to be clamped.

The indexing pins must not protrude more than max. 7mm in order to be able to benefit from the 90° indexing of the GFD console.

When adapting the clamping pins and indexing pins directly into a unprocessed part to be processed, it should be taken into account that the flatness of the bearing surface is max. 0.1 mm.



### 3.1 Function

Before clamping components it is important to ensure that no fragments or other foreign bodies are in the system. This applies in particular to the hole for the clamping pin and the set-up system, which must be clean. 

By operating the clamping screw **b** with approx. 4 turns the clamping slide **c** is pushed into the groove **m** and in this way the clamping pin is pushed into the half-shell shape.

The angled surface at the locking groove has the effect of pulling the clamping pin and hence the component to be clamped downwards on to the set-up system.

With a clamping torque of 30 Nm at the clamping screw **b** maximum pull-down force of 20 kN is achieved.

When changing the clamped component use the clamping screw **b** to retract the clamping slide **c** from the locking groove **m** of the clamping pin.

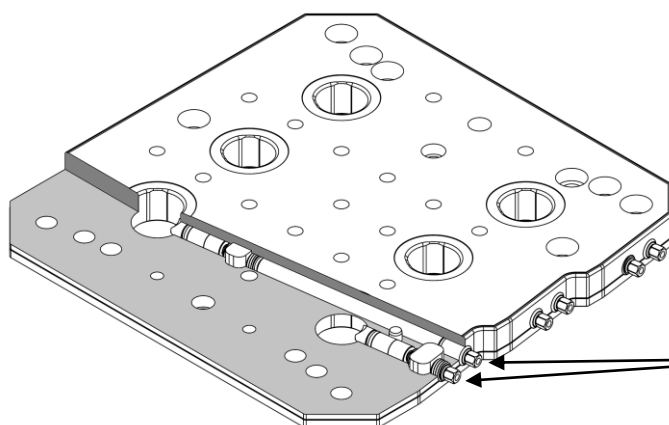
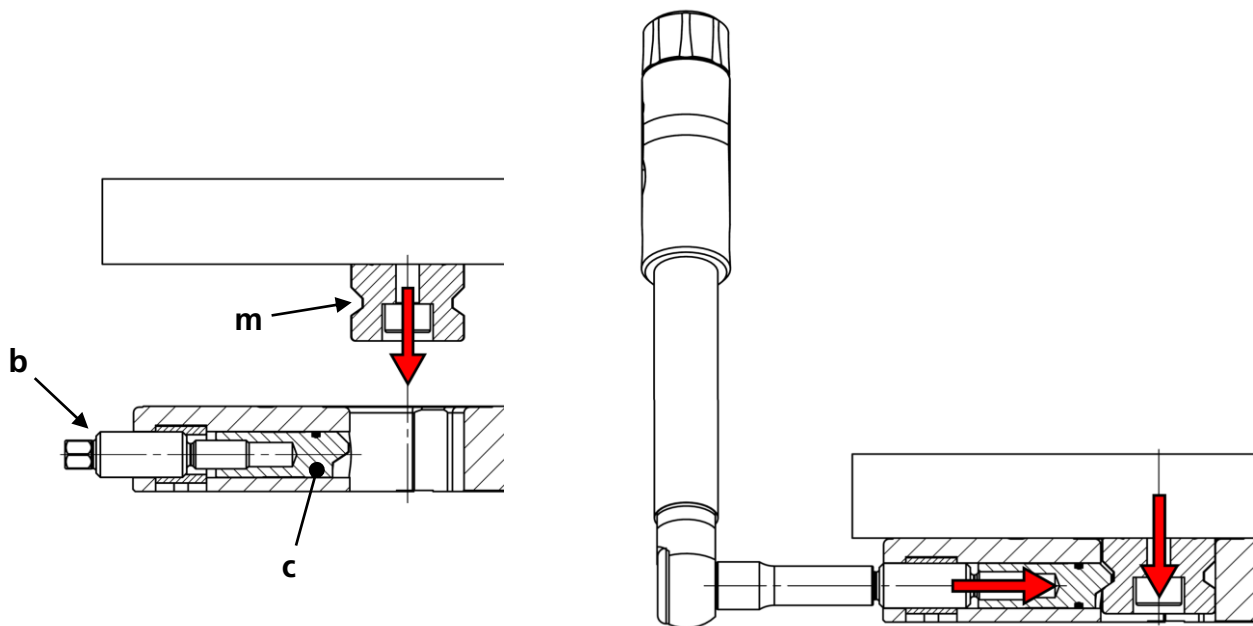

#### Sequence of operation

In order to achieve the best possible repeat accuracy, it is best to always keep to the same clamping sequence when changing components.

Clamping spindle

## 4 Operation

### 4.1 Aligning / Fastening

#### 4.1.1 Fastening on machine table

- Position the GFD set-up station with centring pin **i** on machine table and use the positioning pin **n** to align.
- Insert the slot nuts into the T-nut machine table and fastening with cylinder screw.

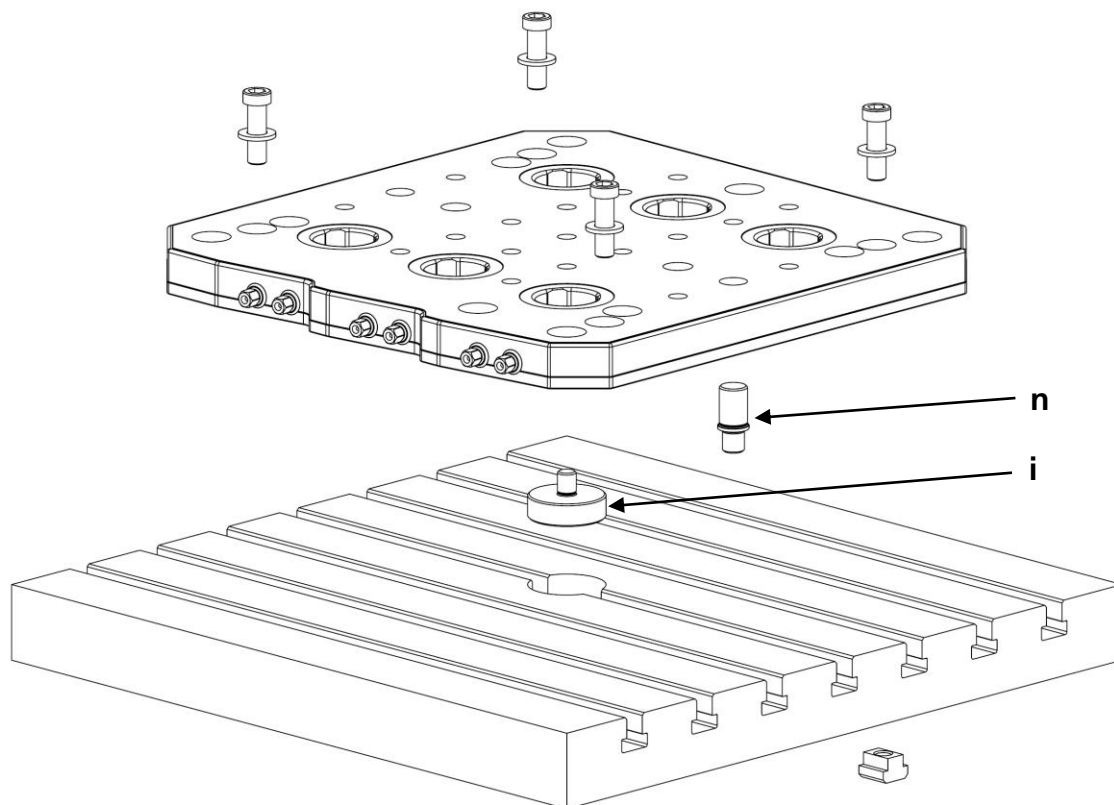

#### 4.1.2 Aligning a GFD set-up station without centring pin and positioning pin

Without the centring pin and positioning pin, the set-up system has to be aligned using the position holes.

**Important:**

The outer edges cannot be used as reference edges.



### 4.1.3 Alignment with several GFD set-up stations

For the alignment of a second set-up system, this must first be approximately aligned to the first.

For exact positioning it is possible to use an alignment aid, which the manufacturer will be to provide.

**Note:**

Please contact the manufacturer for the alignment aid.

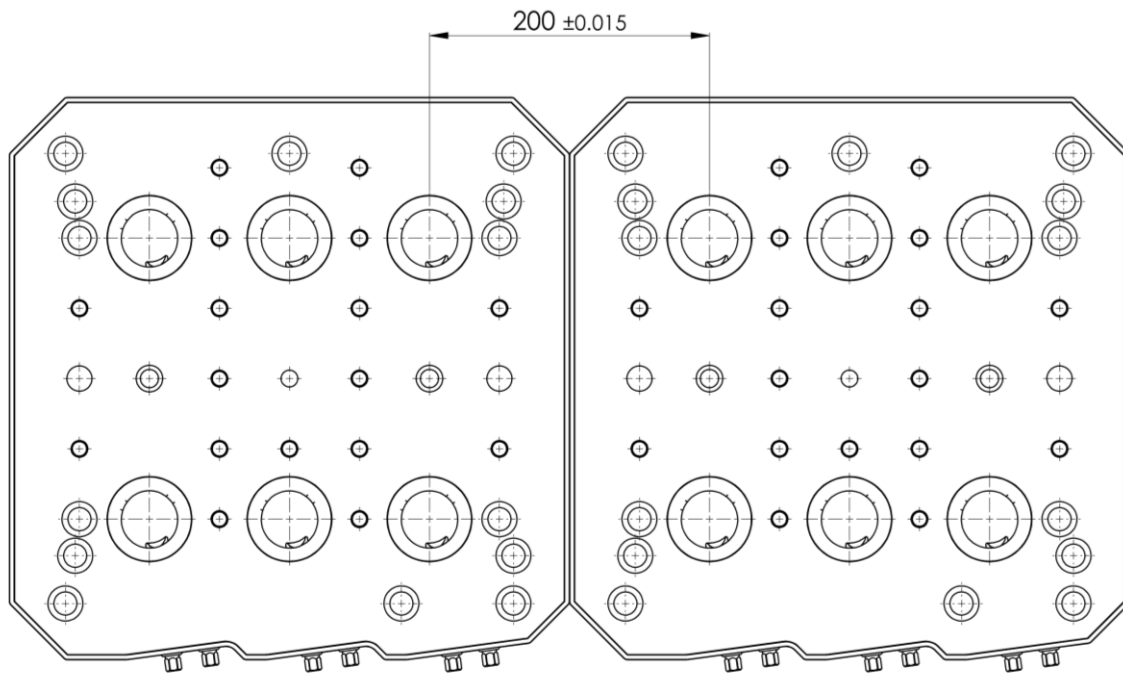
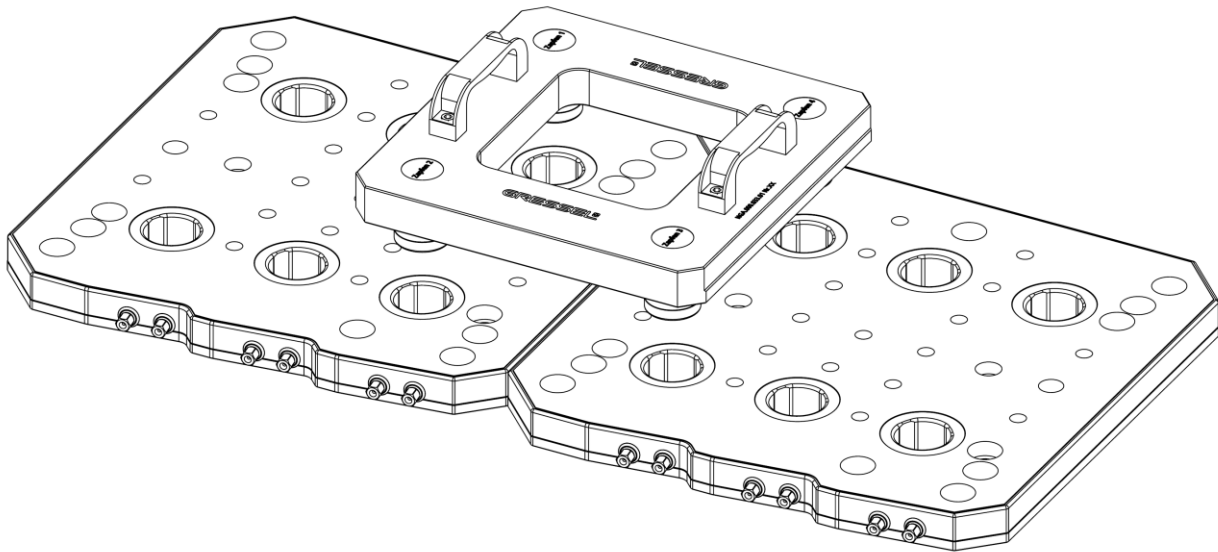

## 5 Covers

### 5.1 Closing plugs for unused locating holes

Insert closing plug  $\varnothing 40$  into the locating hole.

By operating the clamping spindle, the clamping slide is pressed into groove in the closing plug, and close the locating hole.

**Important:**

Tighten the clamping screw only lightly.

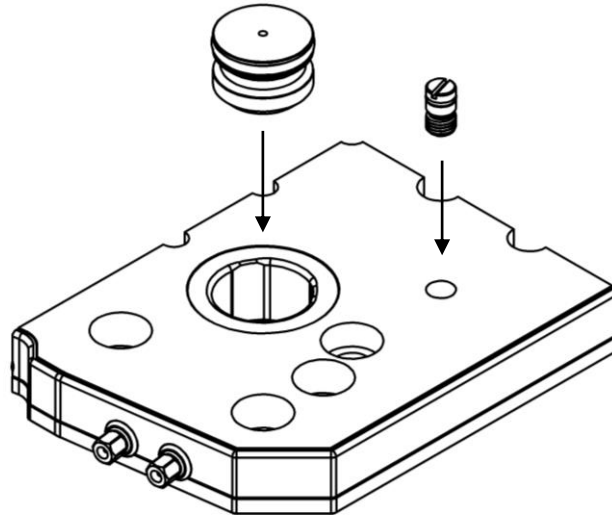

### 5.2 Closing plug for unused grid holes

Turn the closing plug with O-ring.

**Important:**

The closing plug must not protrude from the surface of the set-up system.



## 6 Clamping pin and interface

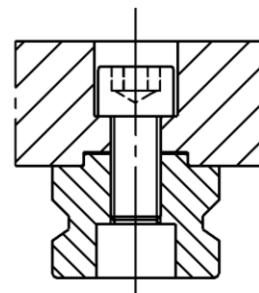
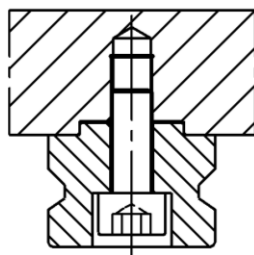
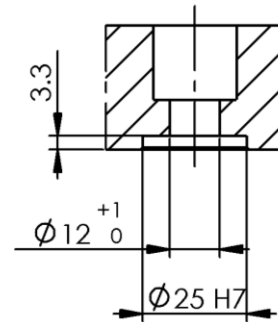
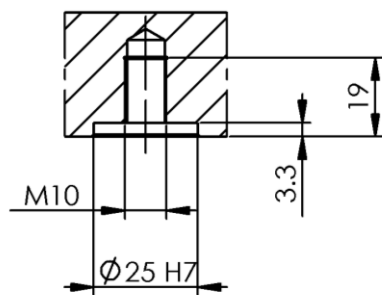
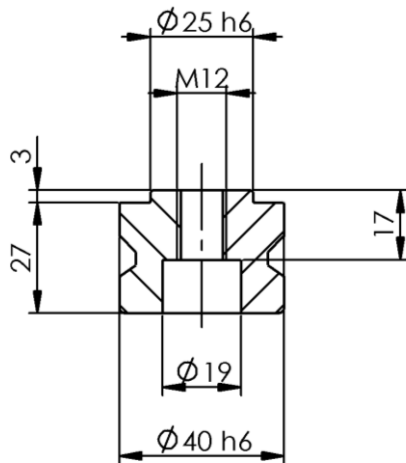

Attaching variant with  
cylinder screw M10x 30

Attaching variant with  
cylinder screw M12x25

## 7 Servicing, cleaning and maintenance

Before clamping components it is important to ensure that no fragments or other foreign bodies are in the system.

This applies in particular to the locating hole for the clamping pin and the set-up system, which must be clean.

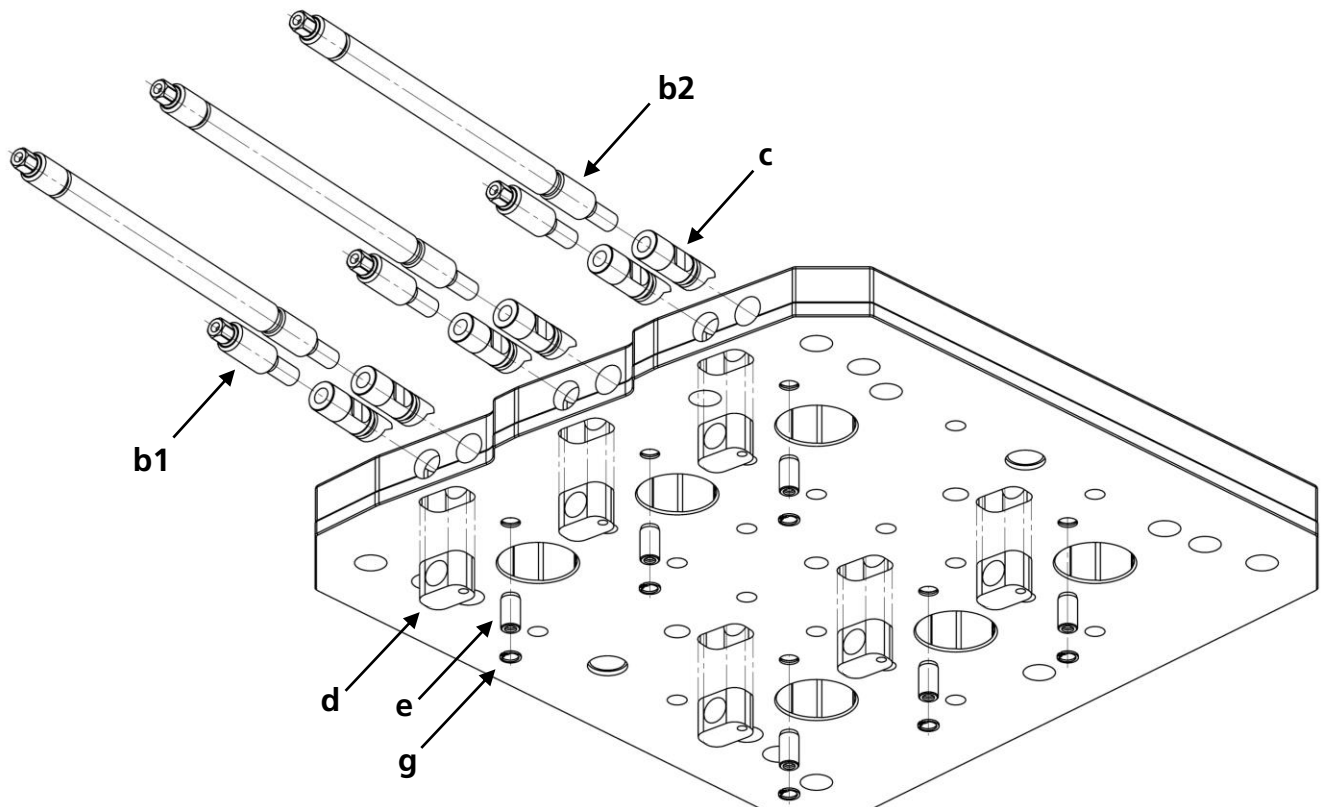

### 7.1 Cleaning / Lubrication

Clean the support and bearing surfaces.

Lubricate the mechanical clamping elements on a regular basis.



- Remove retaining ring **g**.
- Remove cylinder pin **e** by using the thread.
- Turn out the spindle **b1** and **b2**.
- Remove spindle guidance **d** by using the thread.
- Remove clamping slide **c** by using the spindle.
- Clean individual parts.
- Check O-rings and replace if necessary.
- Lubricate threads and holes with Molykote grease.

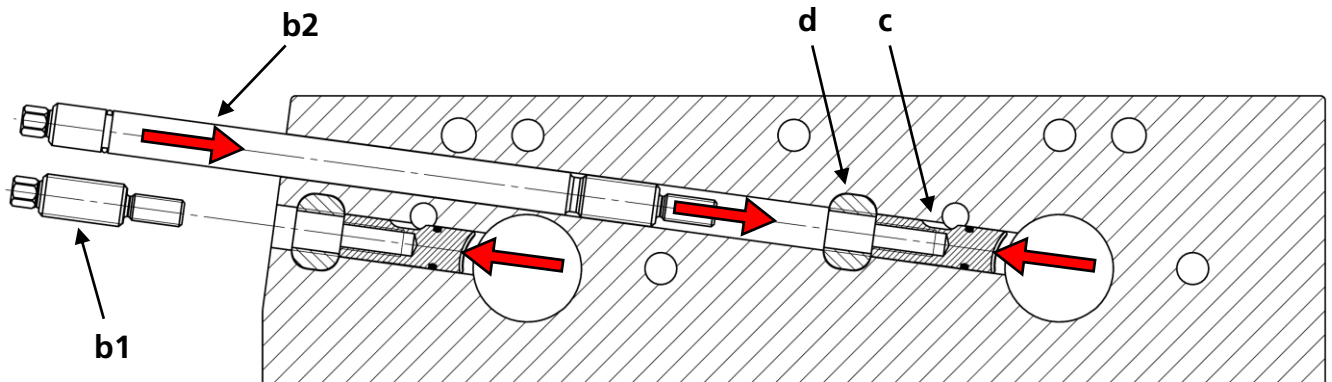

- Reinsert the clamping slide **c** and note the position of the small groove.
- Insert spindle guidance **d** and note that the thread is visible from below.
- Press the clamping slide **c** against the spindle guidance **d** and simultaneously screw the clamping spindles **b1** respectively **b2** into the first thread until the second thread in the spindle guidance **d** begins to engage.

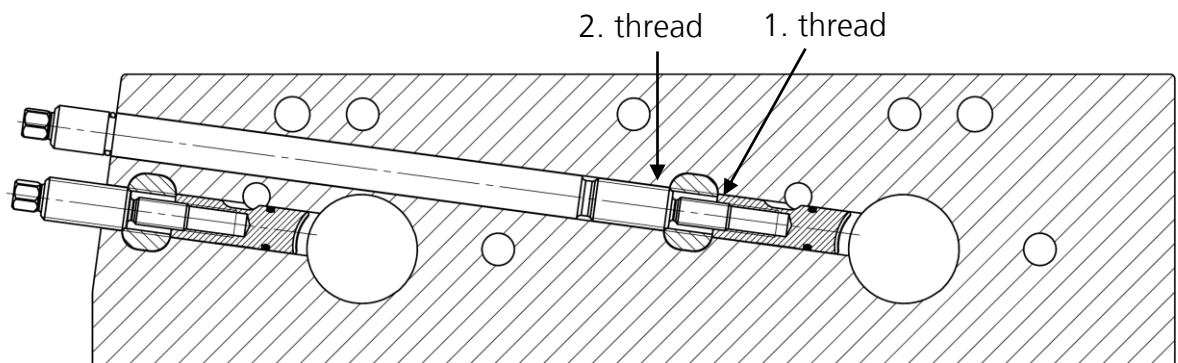

- Turn the clamping spindle further, now the clamping spindle **b** and clamping slide **c** move. Make sure that the clamping slide **c** does not twist.
- Cylinder pin **e** and retaining ring **g** can be refitted again.

### Check the correct screw-in depth:

When is clamped, the clamping spindles must protrude approx. 10 - 13 mm.

## 8 Troubleshooting / Eliminating faults

Clean the support and bearing surfaces.

### 8.1 Clamping screw is not moving freely

Remove these parts and clean and lubricate.

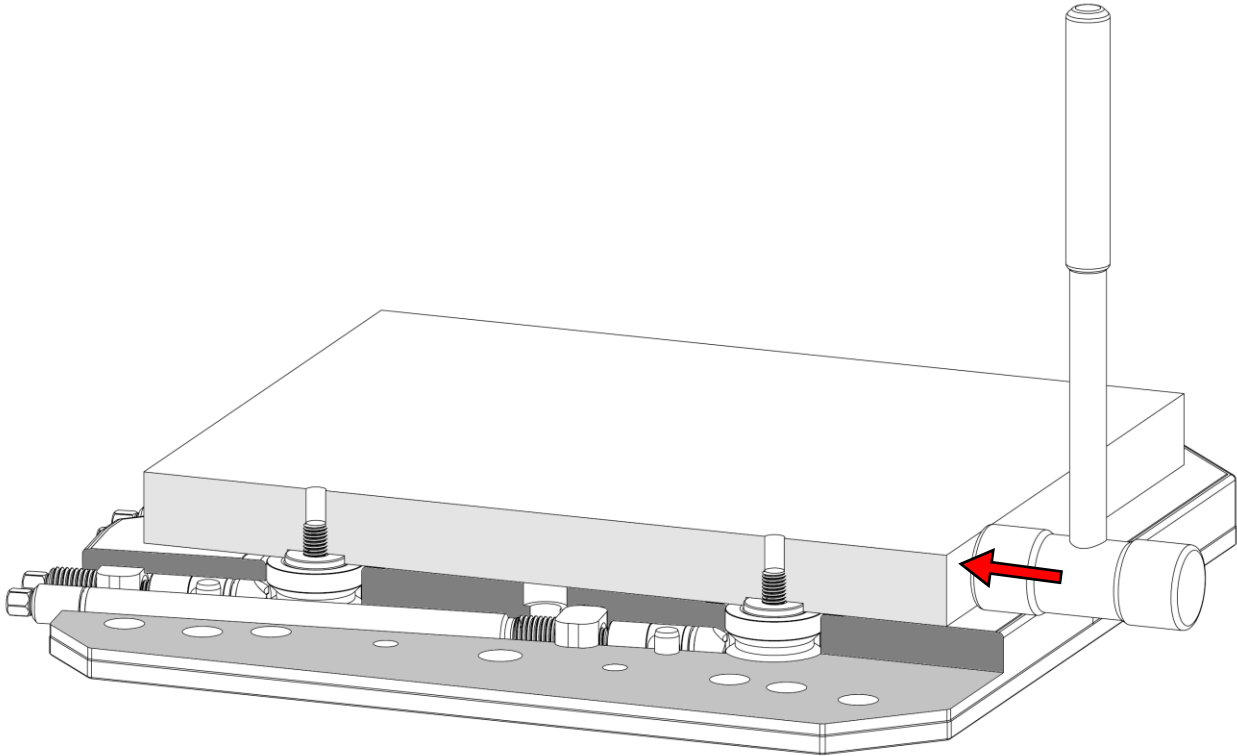

### 8.2 Clamping slide seized up

Release the clamping spindle as far as possible, use plastic hammer to tap on the clamped component from the side opposite the clamping spindle.

This should free the clamping slide so that it can be operated again.

## 9 Assembly drawing

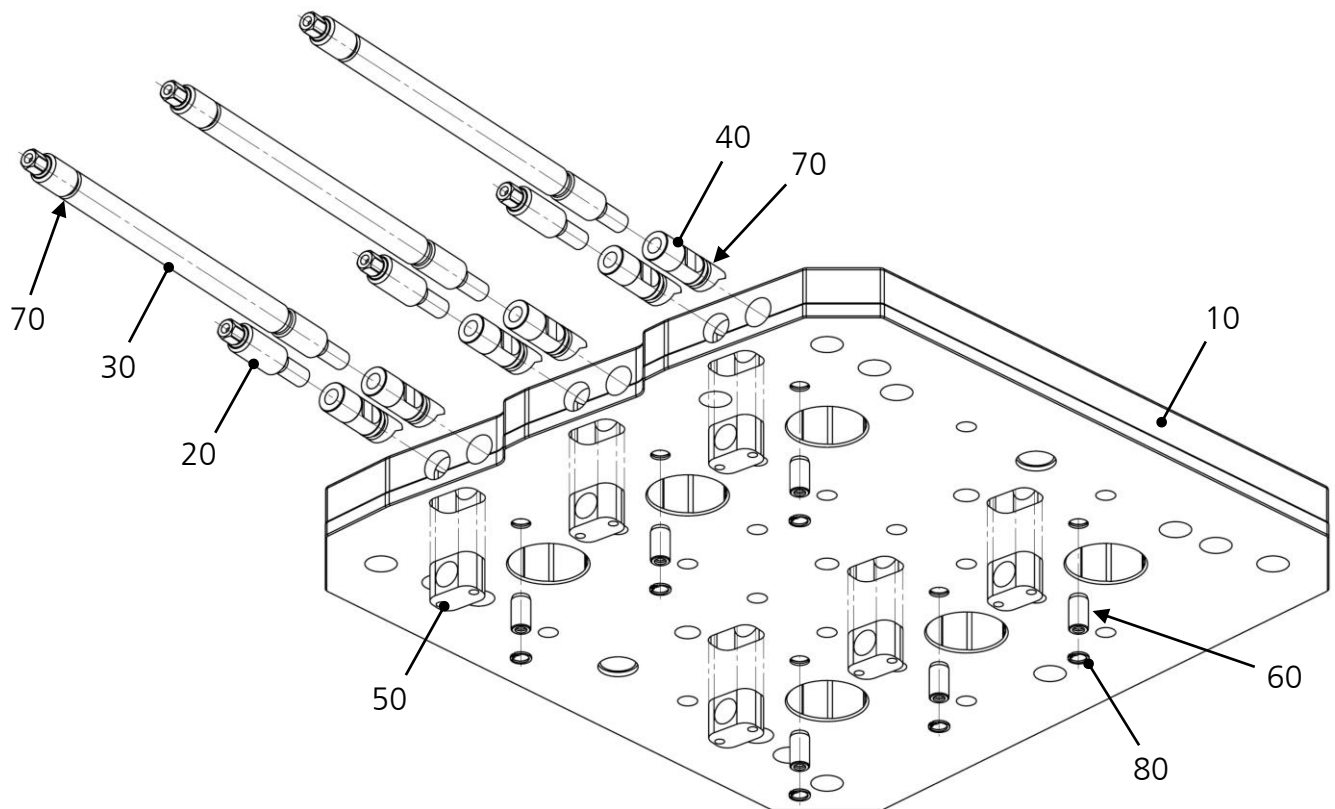

GFD set-up station		4-way 400x330	6-way 400x400	6-way 400x530
Pos.	Designation	Quantity	Quantity	Quantity
10	GFD-NSL-6 400 x 400	-	1	-
	GFD-NSL-4 400 x 330	1	-	-
	GFD-NSL-6 400 x 530	-	-	1
20	Clamping spindle small	2	3	3
30	Clamping spindle medium	2	3	3
40	Clamping slide	4	6	6
50	Spindle guidance M16	4	5	6
60	Pin with internal thread	4	6	6
70	O-ring NBR/70 12.00x2.00	6	9	9
80	Retaining ring Ø10	4	6	6

For information on individual parts of the gredoc NRS 10-fold, please contact the manufacturer.

## 10 Taking out of service

The clamping device and all accessories can be disposed of as scrap metal without any risk.

H.-D. Schunk GmbH & Co.  
Spanntechnik KG  
Lothringer Strasse 23

D-88512 Mengen

Tel.: +49-7572-7614-1300  
Fax: +49-7572-7614-1039

[CMM@de.schunk.com](mailto:CMM@de.schunk.com)  
[schunk.com](http://schunk.com)