

Assembly and operating manual

COS V

Optional module

Translation of original operating
manual

Imprint

Copyright:

This manual is protected by copyright. The author is SCHUNK SE & Co. KG.
All rights reserved.

Technical changes:

We reserve the right to make alterations for the purpose of technical improvement.

Document number: 1626511

Version: 01.00 | 02/06/2025 | en

Dear Customer,

Thank you for trusting our products and our family-owned company, the leading technology supplier of robots and production machines.

Our team is always available to answer any questions on this product and other solutions. Ask us questions and challenge us. We will find a solution!

Best regards,

Your SCHUNK team

Customer Management

Tel. +49-7133-103-2503

Fax +49-7133-103-2189

cmg@de.schunk.com



Please read the operating manual in full and keep it close to the product.

Table of Contents

1 General	5
1.1 About this manual.....	5
1.1.1 Presentation of Warning Labels	5
1.1.2 Definition of Terms	6
1.1.3 Symbol definition.....	6
1.1.4 Applicable documents	6
1.1.5 Sizes.....	6
1.2 Warranty	6
1.3 Scope of delivery.....	7
1.4 Accessories	7
2 Basic safety notes	8
2.1 Intended use.....	8
2.2 Constructional changes.....	8
2.3 Spare parts	8
2.4 Ambient conditions and operating conditions	9
2.5 Personnel qualification	9
2.6 Personal protective equipment	10
2.7 Notes on safe operation.....	10
2.8 Transport.....	11
2.9 Malfunctions.....	11
2.10 Disposal	11
2.11 Fundamental dangers	12
2.11.1 Protection during handling and assembly	12
2.11.2 Protection during commissioning and operation	13
2.11.3 Protection against dangerous movements	13
2.12 Notes on particular risks	14
3 Technical data	15
3.1 Name plate	15
3.2 Ambient conditions and operating conditions	15
4 Design and description	16
4.1 Design	16
4.2 Description	16
5 Mount the optional module	17
6 Troubleshooting	19
7 Maintenance	20
7.1 Maintenance intervals.....	20
7.2 Replacing V-ring seal on master	20

8 Disassembly and disposal	21
9 Certificate of Conformity	22
10 Information on the RoHS Directive, REACH Regulation and Substances of Very High Concern (SVHC)	23

1 General

1.1 About this manual

This manual contains important information for a safe and appropriate use of the product.

This manual is an integral part of the product and must be kept accessible for the personnel at all times.

Before starting work, the personnel must have read and understood this operating manual. Prerequisite for safe working is the observance of all safety instructions in this manual.

In addition to these instructions, the documents listed under ▶ 1.1.4 [6] are applicable.

NOTE: The illustrations in this manual are intended to provide a basic understanding and may deviate from the actual version.

1.1.1 Presentation of Warning Labels

To make risks clear, the following signal words and symbols are used for safety notes.



⚠ DANGER

Dangers for persons!

Non-observance will inevitably cause irreversible injury or death.



⚠ WARNING

Dangers for persons!

Non-observance can lead to irreversible injury and even death.



⚠ CAUTION

Dangers for persons!

Non-observance can cause minor injuries.

NOTICE

Material damage!

Information about avoiding material damage.

1.1.2 Definition of Terms

The term "product" replaces the product name on the title page in this manual.

1.1.3 Symbol definition

The following symbols are used in this manual:

■ Prerequisite for an action

1. Action 1

2. Action 2

⇒ Intermediate results

⇒ Final results

▶ 1.1.3 [6]: chapter number and [page number] in hyperlinks

1.1.4 Applicable documents

- General terms of business *
- Assembly and Operating Manual for the SCHUNK Tool Changer *
- Catalog data sheet of the purchased product *

The documents labeled with an asterisk (*) can be downloaded from [schunk.com/downloads](https://www.schunk.com/downloads).

1.1.5 Sizes

This operating manual applies to the following sizes:

- COS V34-K
- COS V34-A
- COS V112A-K
- COS V112A-A
- COS V200A-K
- COS V200A-A

1.2 Warranty

If the product is used as intended, the warranty is valid for 24 months from the ex-works delivery date under the following conditions:

- Observe the specified maintenance and lubrication intervals
- Observe the ambient conditions and operating conditions

Parts touching the workpiece and wear parts are not included in the warranty.

1.3 Scope of delivery

The scope of delivery includes

- Optional module COS V in the size ordered
- Adapter plate for J screw connection diagram with fastener (V112A, V200A)
- Safety information (product-specific instructions available online)
- Accessory pack
Contents: Fastening screws and cylindrical pins

Size	ID.-No. of the accessory pack
V34-K	1597410
V34-A	1597410
V112A-A	1599272
V200A-A	1599272

Tab.: ID.-No. of the accessory pack

1.4 Accessories

The following accessories are available for the product, which must be ordered separately:

- Spare part package

Size	ID. No. spare part kit	
	FKM seals	Viton seals
V34-K	1590582	1590597
V112A-K	1590589	1590600
V200A-K	1590592	1590601

Tab.: ID. No. spare part kit

For information regarding which accessory articles can be used with the corresponding product variants, see catalog data sheet.

2 Basic safety notes

2.1 Intended use

Size "V" optional modules are used to transmit vacuum from a machine/system to a handling device/tool.

- The product is intended for installation in a machine/ automated system. The applicable guidelines for the machine/ automated system must be observed and complied with.
- The product may only be used within the scope of its technical data, ▶ 3 [15].
- The product is intended for industrial and industry-oriented use. Its use outside enclosed spaces is only permitted if suitable protective measures are taken against outdoor exposure. The product is not suitable for use in salty air.
- Appropriate use of the product includes compliance with all instructions in this manual.
- Never disconnect or connect the module while a medium is being transferred.

Misuse

2.2 Constructional changes

Implementation of structural changes

Modifications, changes or reworking, e.g. additional threads, holes, or safety devices, can damage the product or impair its functionality or safety.

- Structural changes should only be made with the written approval of SCHUNK.

2.3 Spare parts

Use of unauthorized spare parts

Using unauthorized spare parts can endanger personnel and damage the product or cause it to malfunction.

- Use only original spare parts or spares authorized by SCHUNK.

2.4 Ambient conditions and operating conditions

Required ambient conditions and operating conditions

Incorrect ambient and operating conditions can make the product unsafe, leading to the risk of serious injuries, considerable material damage and/or a significant reduction to the product's life span.

- Make sure that the product is used only in the context of its defined application parameters, ▶ 3 [15].

2.5 Personnel qualification

Inadequate qualifications of the personnel

If the personnel working with the product is not sufficiently qualified, the result may be serious injuries and significant property damage.

- All work may only be performed by qualified personnel.
- Before working with the product, the personnel must have read and understood the complete assembly and operating manual.
- Observe the national safety regulations and rules and general safety instructions.

The following personal qualifications are necessary for the various activities related to the product:

Trained electrician

Due to their technical training, knowledge and experience, trained electricians are able to work on electrical systems, recognize and avoid possible dangers and know the relevant standards and regulations.

Qualified personnel

Due to its technical training, knowledge and experience, qualified personnel is able to perform the delegated tasks, recognize and avoid possible dangers and knows the relevant standards and regulations.

Instructed person

Instructed persons were instructed by the operator about the delegated tasks and possible dangers due to improper behaviour.

Service personnel of the manufacturer

Due to its technical training, knowledge and experience, service personnel of the manufacturer is able to perform the delegated tasks and to recognize and avoid possible dangers.

2.6 Personal protective equipment

Use of personal protective equipment

Personal protective equipment serves to protect staff against danger which may interfere with their health or safety at work.

- When working on and with the product, observe the occupational health and safety regulations and wear the required personal protective equipment.
- Observe the valid safety and accident prevention regulations.
- Wear protective gloves to guard against sharp edges and corners or rough surfaces.
- Wear heat-resistant protective gloves when handling hot surfaces.
- Wear protective gloves and safety goggles when handling hazardous substances.
- Wear close-fitting protective clothing and also wear long hair in a hairnet when dealing with moving components.

2.7 Notes on safe operation

Incorrect handling of the personnel

Incorrect handling and assembly may impair the product's safety and cause serious injuries and considerable material damage.

- Avoid any manner of working that may interfere with the function and operational safety of the product.
- Use the product as intended.
- Observe the safety notes and assembly instructions.
- Do not expose the product to any corrosive media. This does not apply to products that are designed for special environments.
- Eliminate any malfunction immediately.
- Observe the care and maintenance instructions.
- Observe the current safety, accident prevention and environmental protection regulations regarding the product's application field.

2.8 Transport

Handling during transport

Incorrect handling during transport can make the product unsafe and risk the danger of serious injuries and considerable material damage.

- During transport and handling, secure the product to prevent it from falling.
- Do not walk under suspended loads.

2.9 Malfunctions

Behavior in case of malfunctions

- Immediately remove the product from operation and report the malfunction to the responsible departments/persons.
- Order appropriately trained personnel to rectify the malfunction.
- Do not recommission the product until the malfunction has been rectified.
- Test the product after a malfunction to establish whether it still functions properly and no increased risks have arisen.

2.10 Disposal

Handling of disposal

The incorrect handling of disposal may impair the product's safety and cause serious injuries as well as considerable material and environmental harm.

- Follow local regulations on dispatching product components for recycling or proper disposal.

2.11 Fundamental dangers

General

- Observe safety distances.
- Never deactivate safety devices.
- Before commissioning the product, take appropriate protective measures to secure the danger zone.
- Disconnect power sources before installation, modification, maintenance, or calibration. Ensure that no residual energy remains in the system.
- If the energy supply is connected, do not move any parts by hand.
- Do not reach into the open mechanism or movement area of the product during operation.

2.11.1 Protection during handling and assembly

Incorrect handling and assembly

Incorrect handling and assembly may impair the product's safety and cause serious injuries and considerable material damage.

- Have all work carried out by appropriately qualified personnel.
- For all work, secure the product against accidental operation.
- Observe the relevant accident prevention rules.
- Use suitable assembly and transport equipment and take precautions to prevent jamming and crushing.

Incorrect lifting of loads

Falling loads may cause serious injuries and even death.

- Stand clear of suspended loads and do not step into their swiveling range.
- Never move loads without supervision.
- Do not leave suspended loads unattended.

2.11.2 Protection during commissioning and operation

Falling or violently ejected components

Falling and violently ejected components can cause serious injuries and even death.

- Take appropriate protective measures to secure the danger zone.
- Never step into the danger zone during operation.

2.11.3 Protection against dangerous movements

Unexpected movements

Residual energy in the system may cause serious injuries while working with the product.

- Switch off the energy supply, ensure that no residual energy remains and secure against inadvertent reactivation.
- Never rely solely on the response of the monitoring function to avert danger. Until the installed monitors become effective, it must be assumed that the drive movement is faulty, with its action being dependent on the control unit and the current operating condition of the drive. Perform maintenance work, modifications, and attachments outside the danger zone defined by the movement range.
- To avoid accidents and/or material damage, human access to the movement range of the machine must be restricted. Limit/prevent accidental access for people in this area due through technical safety measures. The protective cover and protective fence must be rigid enough to withstand the maximum possible movement energy. EMERGENCY STOP switches must be easily and quickly accessible. Before starting up the machine or automated system, check that the EMERGENCY STOP system is working. Prevent operation of the machine if this protective equipment does not function correctly.

2.12 Notes on particular risks



⚠ WARNING

Risk of injury from electric shock due to contact with live parts!

- Before starting any work: Disconnect the power supply from the mains and secure against accidental switch-on.
- Work may only be performed by appropriately qualified personnel.



⚠ WARNING

Risk of burns due to touching hot surfaces!

High operating temperatures can cause components to heat up considerably. Skin contact with hot surfaces causes severe burns to the skin.

- Wear safety gloves during all work in the vicinity of hot surfaces.
- Before carrying out any work, make sure that all surfaces have cooled down to the ambient temperature.



⚠ CAUTION

Risk of injury from objects falling and being ejected!

Falling and ejected objects during operation can lead to injuries.

- Take suitable protective measures to secure the danger zone.



⚠ CAUTION

Risk of injury from sharp edges and corners!

Sharp edges and corners can cause cuts.

- Wear suitable protective equipment.

3 Technical data

3.1 Name plate

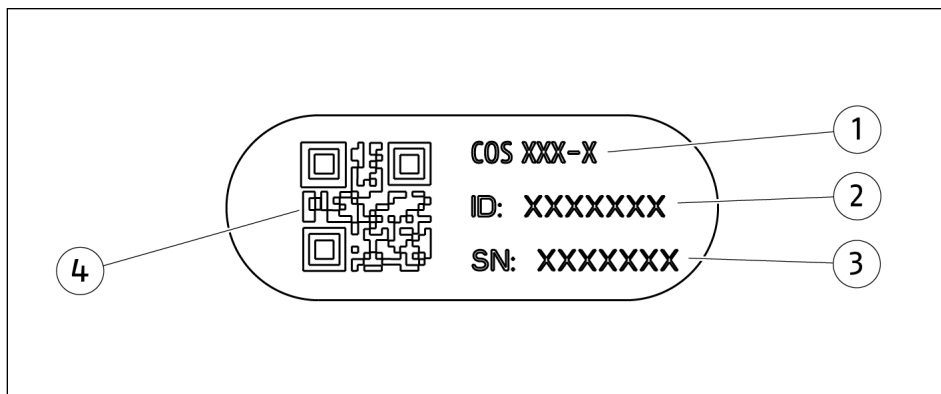

- | | |
|---|---------------------|
| 1 | Product designation |
| 2 | ID |
| 3 | Serial number |
| 4 | Data matrix code |

Scan the code or serial number and enter on the web and receive additional product information: CAD data, catalog data sheets, spare parts packages, software updates etc.

For further information, visit [schunk.com/serialisierung](https://www.schunk.com/serialisierung)

A separate app may be required for scanning with a mobile phone.

3.2 Ambient conditions and operating conditions

Designation	Value
Ambient temperature [°C]	
min.	+5
max.	+60
Protection class IP in coupled state	65

More technical data is included in the catalog data sheet. Whichever is the latest version.

4 Design and description

4.1 Design

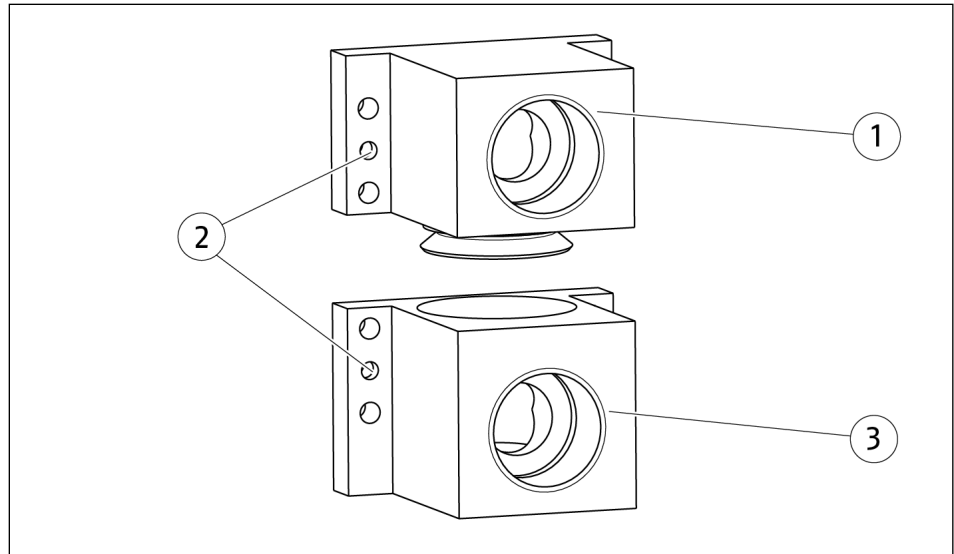

Optional module COS V

- | | |
|---|---|
| 1 | COS V-K: Master side, suitable for the master |
| 2 | Attachment to master and tool of the tool changer |
| 3 | COS V-A: Tool side, suitable for the tool |

4.2 Description

Optional module for vacuum transfer.

5 Mount the optional module

COS V34

- Energy supply is switched off.
 - The master and tool are decoupled.
1. Check the mounting surfaces of the optional modules for a flush fit. Use adapter plate if necessary.
 2. Mount optional module COS V-K with four screws (1) and two cylindrical pins (2) onto the master.
 - ⇒ Tightening torque [Nm]: 2.2
 3. Mount optional module COS V-A with four screws (4) and two cylindrical pins (3) onto the tool.
 - ⇒ Tightening torque [Nm]: 2.2

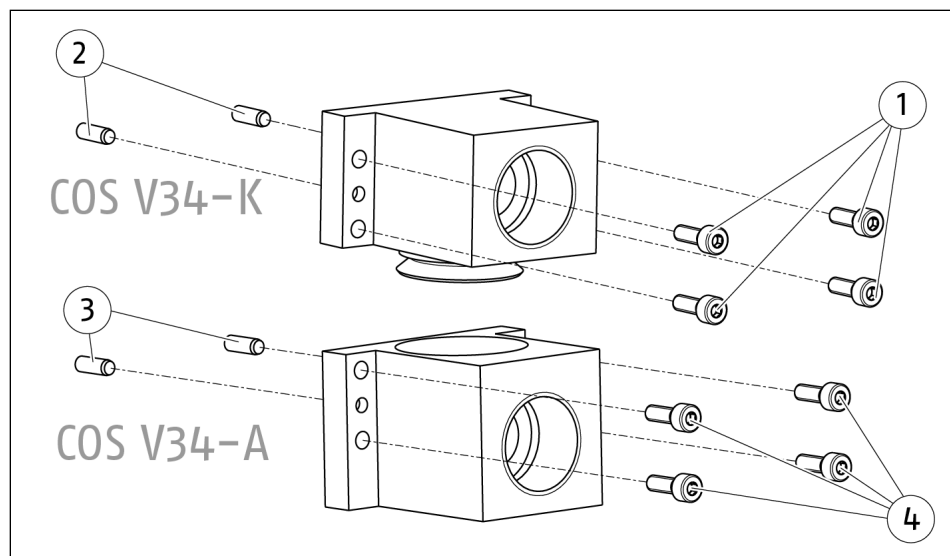

Mounting optional module COS V34

COS V112A, 200A

- Energy supply is switched off.
- The master and tool are decoupled.
- 1. Check the mounting surfaces of the optional modules for a flush fit. Use adapter plate if necessary.
- 2. Mount optional module COS V-K with adapter plate, eight screws (1) and four cylindrical pins (2) onto the master.
 - ⇒ Tightening torque [Nm]: 2.2
- 3. Mount optional module COS V-A with adapter plate, eight screws (4) and four cylindrical pins (3) onto the tool.
 - ⇒ Tightening torque [Nm]: 2.2

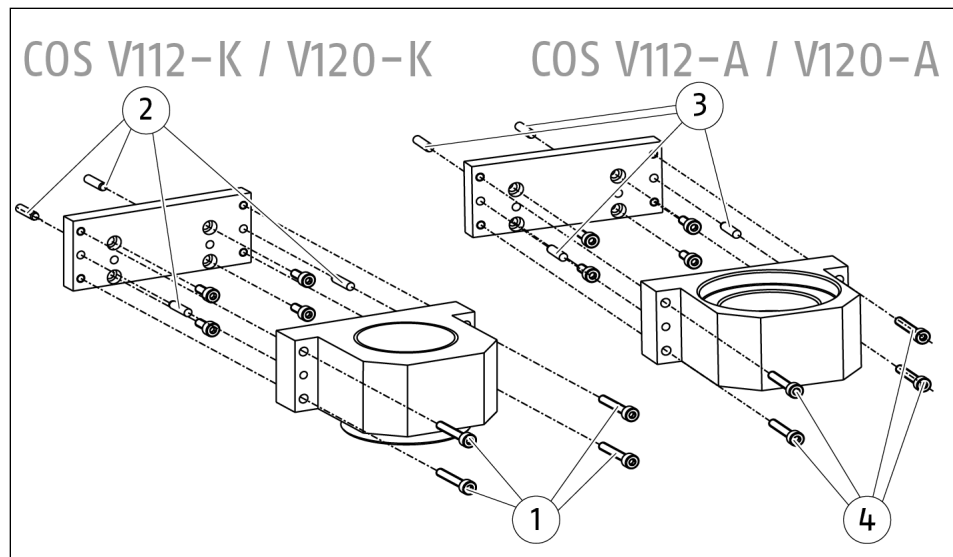

Mounting optional module COS V112, 200

For further information, please refer to the catalog data sheets for the optional module, ► 1.1.4 [6].

6 Troubleshooting

Problem	Possible cause	Corrective action
Leakage	Worn V-ring seal.	Replace V-ring seal, ▶ 7.2 [📄 20].
Poor vacuum	Vacuum connection is blocked.	Check modules and supply lines for blockages and clean.
Modules not coupling	Loose fastening elements	Check and tighten the module fastening on the tool changer.

7 Maintenance

7.1 Maintenance intervals

Maintenance interval	Maintenance work
monthly	Check optional module for damage and wear, clean if necessary, and replace seals, ▶ 7.2 [20].
as required	Send damaged products to SCHUNK for repair.

7.2 Replacing V-ring seal on master

- Energy supply is switched off.
- 1. Remove seal from COS V-K.
- 2. Check seal for wear or damage.
- 3. Carefully pull the new seal apart with your fingers and pull over the connecting piece on the COS V-K.
- 4. Press the seal into the groove of the connecting piece.

8 Disassembly and disposal



⚠ WARNING

Risk of injury due to unexpected movements!

If the power supply is switched on or residual energy remains in the system, components can move unexpectedly and cause serious injuries.

- Before starting any work on the product: Switch off the power supply and secure against restarting.
 - Make sure, that no residual energy remains in the system.
-
- Disconnect the entire energy supply from the product, discharge any accumulated residual energy.
 - Remove any lubricant and dispose of in an environmentally friendly manner.
 - Follow local regulations on dispatching product components for recycling or proper disposal.

9 Certificate of Conformity

Manufacturer/
Distributor SCHUNK SE & Co. KG
Spanntechnik | Greiftechnik | Automatisierungstechnik
Bahnhofstr. 106 – 134
D-74348 Lauffen/Neckar

We hereby declare on our sole authority that the product meets the requirements of the following directives at the time of the declaration.

The declaration is rendered invalid if modifications are made to the product.

Product designation: Optional module / COS V /

ID number: 1586748, 1586750, 1586744, 1586745, 1586746, 1586747

Applicable directives:

2001/95/EC General product safety

Applied harmonized standards, especially:

EN ISO 12100:2010 Safety of machinery – General principles for design –
Risk assessment and risk reduction

Person authorized to compile the technical documentation:

Stefanie Walter, Address: see manufacturer's address

Signature: see original declaration

Dr.-Ing. Manuel Baumeister,
Head of Systems Engineering,
Technology & Innovation

Lauffen/Neckar, June 2025

10 Information on the RoHS Directive, REACH Regulation and Substances of Very High Concern (SVHC)

RoHS Directive

SCHUNK products are classified as "large-scale stationary installations" or as "large-scale stationary industrial tools" within the meaning of Directive 2011/65/EU and its extension 2015/863/EU "on the restriction of the use of certain hazardous substances in electrical and electronic equipment (RoHS)", or fulfill their intended function only as part of one. Therefore products from SCHUNK do not fall within the scope of the directive at this time.

REACH Regulation

Products from SCHUNK fully comply with the regulations of Regulation (EC) No. 1907/2006 "concerning the Registration, Evaluation, Authorization and Restriction of Chemicals (REACH)" and its amendment 2022/477. SCHUNK attaches great importance to completely avoiding chemicals of concern to humans and the environment wherever possible.

Only in rare exceptional cases do SCHUNK products contain SVHC substances on the candidate list with a mass content above 0.1%. In accordance with Article. 33 (1) of Regulation (EC) No. 1907/2006, SCHUNK complies with its duty to "communicate information on substances in articles" and lists the components concerned and the substances used in an overview that can be viewed at [schunk.com/SVHC](https://www.schunk.com/SVHC).

Signature: see original declaration

Dr.-Ing. Manuel Baumeister,
Head of Systems Engineering,
Technology & Innovation

Lauffen/Neckar, June 2025



SCHUNK SE & Co. KG
Spanntechnik | Greiftechnik | Automatisierungstechnik

Bahnhofstr. 106 - 134
D-74348 Lauffen/Neckar
Tel. +49-7133-103-0
info@de.schunk.com
schunk.com

Folgen Sie uns | *Follow us*



Wir drucken nachhaltig | *We print sustainable*