

Assembly and Operating Manual

CTS

Modular storage rack

Translation of Original Operating
Manual

Imprint

Copyright:

This manual is protected by copyright. The author is SCHUNK SE & Co. KG.
All rights reserved.

Technical changes:

We reserve the right to make alterations for the purpose of technical improvement.

Document number: 1629566

Version: 01.00 | 02/06/2025 | en

Dear Customer,

Thank you for trusting our products and our family-owned company, the leading technology supplier of robots and production machines.

Our team is always available to answer any questions on this product and other solutions. Ask us questions and challenge us. We will find a solution!

Best regards,

Your SCHUNK team

Customer Management

Tel. +49-7133-103-2503

Fax +49-7133-103-2189

cmg@de.schunk.com



Please read the operating manual in full and keep it close to the product.

Table of Contents

1 General	4
1.1 About this manual.....	4
1.1.1 Presentation of Warning Labels	4
1.1.2 Definition of Terms	5
1.1.3 Symbol definition.....	5
1.1.4 Applicable documents	5
1.1.5 Sizes.....	5
1.2 Warranty	5
1.3 Scope of delivery.....	6
1.4 Accessories	6
2 Basic safety notes	7
2.1 Appropriate use	7
2.2 Constructional changes.....	7
2.3 Spare parts	7
2.4 Ambient conditions and operating conditions	7
2.5 Personnel qualification	8
2.6 Personal protective equipment	9
2.7 Transport.....	9
2.8 Malfunctions.....	9
2.9 Fundamental dangers	10
2.9.1 Protection during handling and assembly	10
2.9.2 Protection during commissioning and operation	11
2.10 Notes on particular risks	11
3 Technical data	12
4 Design and description	13
5 Notes on mounting.....	17
6 Troubleshooting.....	18
7 Maintenance	19
7.1 Maintenance intervals.....	19
8 Disassembly and disposal	20
9 Certificate of Conformity	21
10 Information on the RoHS Directive, REACH Regulation and Substances of Very High Concern (SVHC)	22

1 General

1.1 About this manual

This manual contains important information for a safe and appropriate use of the product.

This manual is an integral part of the product and must be kept accessible for the personnel at all times.

Before starting work, the personnel must have read and understood this operating manual. Prerequisite for safe working is the observance of all safety instructions in this manual.

In addition to these instructions, the documents listed under ▶ 1.1.4 [📄 5] are applicable.

NOTE: The illustrations in this manual are intended to provide a basic understanding and may deviate from the actual version.

1.1.1 Presentation of Warning Labels

To make risks clear, the following signal words and symbols are used for safety notes.



⚠ DANGER

Dangers for persons!

Non-observance will inevitably cause irreversible injury or death.



⚠ WARNING

Dangers for persons!

Non-observance can lead to irreversible injury and even death.



⚠ CAUTION

Dangers for persons!

Non-observance can cause minor injuries.

NOTICE

Material damage!

Information about avoiding material damage.

1.1.2 Definition of Terms

The term "product" replaces the product name on the title page in this manual.

1.1.3 Symbol definition

The following symbols are used in this manual:

■ Prerequisite for an action

1. Action 1

2. Action 2

⇒ Intermediate results

⇒ Final results

▶ 1.1.3 [📄 5]: chapter number and [page number] in hyperlinks

1.1.4 Applicable documents

- General terms of business *
- Catalog data sheet of the purchased product *
- Assembly and Operating Manual of the storage module CTS B

The documents labeled with an asterisk (*) can be downloaded from schunk.com/downloads.

1.1.5 Sizes

This operating manual applies to the following sizes:

- CTS T-001
- CTS T-016
- CTS C-016
- CTS C-025
- CTS P-050
- CTS P-150
- CTS P-500

1.2 Warranty

If the product is used as intended, the warranty is valid for 24 months from the ex-works delivery date under the following conditions:

- Observe the ambient conditions and operating conditions

Parts touching the workpiece and wear parts are not included in the warranty.

1.3 Scope of delivery

The scope of delivery includes

- Modular storage rack CTS in the ordered size
- Safety information (product-specific instructions available online)
- Accessory pack

1.4 Accessories

A wide range of accessories are available for this product

For information regarding which accessory articles can be used with the corresponding product variants, see catalog data sheet.

2 Basic safety notes

2.1 Appropriate use

- Modular storage magazines are designed to store and provide tools precisely in order to ensure fast, smooth and error-free tool changes during machine operation.
- The product may only be used within the scope of its technical data, ▶ 3 [📄 000].
- The product is intended for industrial and industry-oriented use.
- The product is intended for installation in a machine/ automated system. The applicable guidelines for the machine/ automated system must be observed and complied with.
- Appropriate use of the product includes compliance with all instructions in this manual.

2.2 Constructional changes

Implementation of structural changes

Modifications, changes or reworking, e.g. additional threads, holes, or safety devices, can damage the product or impair its functionality or safety.

- Structural changes should only be made with the written approval of SCHUNK.

2.3 Spare parts

Use of unauthorized spare parts

Using unauthorized spare parts can endanger personnel and damage the product or cause it to malfunction.

- Use only original spare parts or spares authorized by SCHUNK.

2.4 Ambient conditions and operating conditions

Required ambient conditions and operating conditions

Incorrect ambient and operating conditions can make the product unsafe, leading to the risk of serious injuries, considerable material damage and/or a significant reduction to the product's life span.

- Make sure that the product is used only in the context of its defined application parameters, ▶ 3 [📄 000].

2.5 Personnel qualification

Inadequate qualifications of the personnel

If the personnel working with the product is not sufficiently qualified, the result may be serious injuries and significant property damage.

- All work may only be performed by qualified personnel.
- Before working with the product, the personnel must have read and understood the complete assembly and operating manual.
- Observe the national safety regulations and rules and general safety instructions.

The following personal qualifications are necessary for the various activities related to the product:

Trained electrician

Due to their technical training, knowledge and experience, trained electricians are able to work on electrical systems, recognize and avoid possible dangers and know the relevant standards and regulations.

Qualified personnel

Due to its technical training, knowledge and experience, qualified personnel is able to perform the delegated tasks, recognize and avoid possible dangers and knows the relevant standards and regulations.

Instructed person

Instructed persons were instructed by the operator about the delegated tasks and possible dangers due to improper behaviour.

Service personnel of the manufacturer

Due to its technical training, knowledge and experience, service personnel of the manufacturer is able to perform the delegated tasks and to recognize and avoid possible dangers.

2.6 Personal protective equipment

Use of personal protective equipment

Personal protective equipment serves to protect staff against danger which may interfere with their health or safety at work.

- When working on and with the product, observe the occupational health and safety regulations and wear the required personal protective equipment.
- Observe the valid safety and accident prevention regulations.
- Wear protective gloves to guard against sharp edges and corners or rough surfaces.
- Wear heat-resistant protective gloves when handling hot surfaces.
- Wear protective gloves and safety goggles when handling hazardous substances.
- Wear close-fitting protective clothing and also wear long hair in a hairnet when dealing with moving components.

2.7 Transport

Handling during transport

Incorrect handling during transport can make the product unsafe and risk the danger of serious injuries and considerable material damage.

- During transport and handling, secure the product to prevent it from falling.
- Do not walk under suspended loads.

2.8 Malfunctions

Behavior in case of malfunctions

- Immediately remove the product from operation and report the malfunction to the responsible departments/persons.
- Order appropriately trained personnel to rectify the malfunction.
- Do not recommission the product until the malfunction has been rectified.
- Test the product after a malfunction to establish whether it still functions properly and no increased risks have arisen.

2.9 Fundamental dangers

General

- Observe safety distances.
- Never deactivate safety devices.
- Before commissioning the product, take appropriate protective measures to secure the danger zone.
- Disconnect power sources before installation, modification, maintenance, or calibration. Ensure that no residual energy remains in the system.
- If the energy supply is connected, do not move any parts by hand.
- Do not reach into the open mechanism or movement area of the product during operation.

2.9.1 Protection during handling and assembly

Incorrect handling and assembly

Incorrect handling and assembly may impair the product's safety and cause serious injuries and considerable material damage.

- Have all work carried out by appropriately qualified personnel.
- For all work, secure the product against accidental operation.
- Observe the relevant accident prevention rules.
- Use suitable assembly and transport equipment and take precautions to prevent jamming and crushing.

Incorrect lifting of loads

Falling loads may cause serious injuries and even death.

- Stand clear of suspended loads and do not step into their swiveling range.
- Never move loads without supervision.
- Do not leave suspended loads unattended.

2.9.2 Protection during commissioning and operation

Falling or violently ejected components

Falling and violently ejected components can cause serious injuries and even death.

- Take appropriate protective measures to secure the danger zone.
- Never step into the danger zone during operation.

2.10 Notes on particular risks



⚠ WARNING

Risk of injury from objects falling and being ejected!

Falling and ejected objects during operation can lead to serious injury or death.

- Take appropriate protective measures to secure the danger zone.



⚠ CAUTION

Risk of injury from sharp edges and corners!

Sharp edges and corners can cause cuts.

- Wear suitable protective equipment.

3 Technical data

Designation	Value
Ambient temperature [°C]	
min.	+5
max.	+60

More technical data is included in the catalog data sheet.
Whichever is the latest version.

4 Design and description

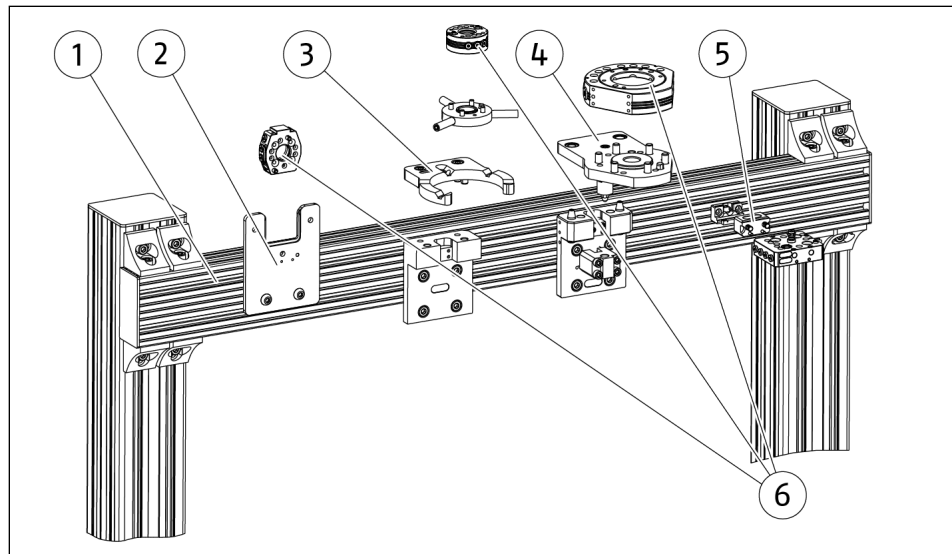

Modular storage rack CTS

- | | |
|---|----------------------|
| 1 | Profile structure |
| 2 | Storage module CTS T |
| 3 | Storage module CTS C |
| 4 | Storage module CTS P |
| 5 | Storage module CTS B |
| 6 | Tool |

Automatic tool changers (CPS and CPB) use modular storage magazines to store and provide tools quickly and efficiently, ensuring smooth and fast tool changes during machine operation. The storage magazines are designed to hold the tools in an exact position to enable precise and error-free transfer to the tool changer.

To deposit a tool, the robot inserts the tool changer to which the tool is mounted into the storage gate of the storage system

Profile structure

The aluminum profiles of the storage magazine, consisting of upright and cross profiles, can be combined and adapted to customer-specific applications. The profiles are available in various designs. See the catalog data sheet for more information.

Storage modules

Four different storage modules are available:

CTS T

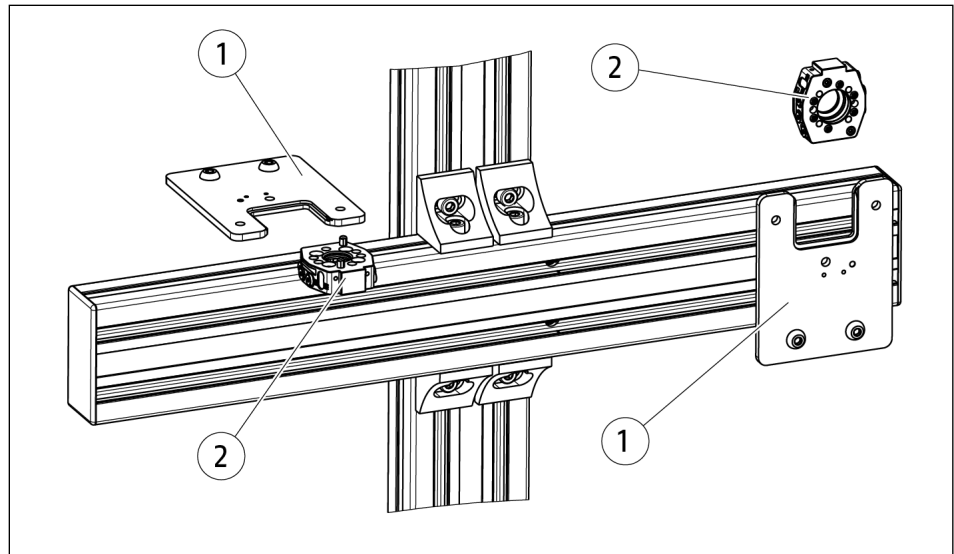

Storage module CTS T

1 Storage rack

2 Tool

The storage rack (1) can be attached horizontally or vertically to a profile. The groove of the interchangeable adapter (2) is pushed onto the plate and then held in the desired position with a catch.

CTS C

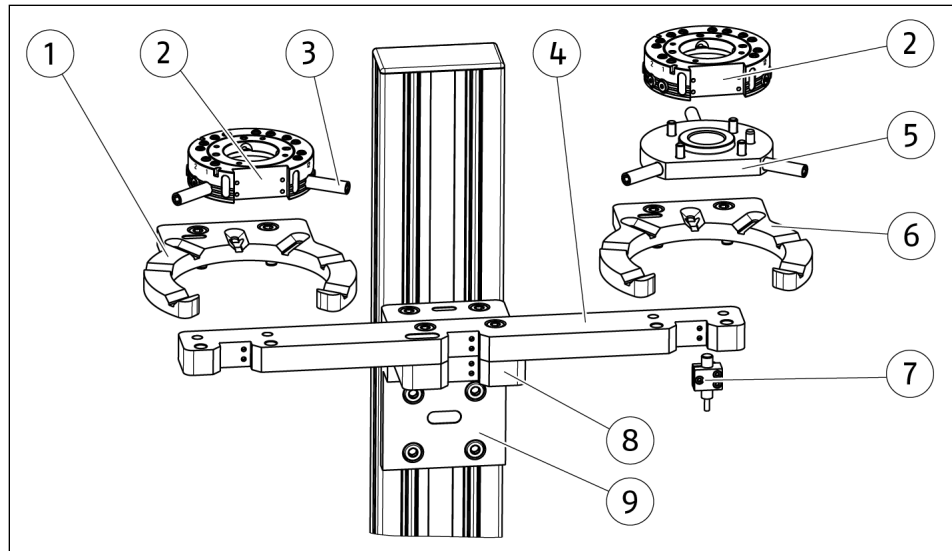

Storage module CTS C

1, 6	Storage module
2	Tool
3	Storage pins *
4	Position adapter *
5	Adapter plate *
7	Inductive proximity switch *
8	Extension adapter *
9	Fixing block *

* Available as an accessory from SCHUNK. See the catalog data sheet for more information.

The storage module (1, 6) can be attached to an aluminum profile using a mounting block (9). The tool (2) with mounted storage pin (3) is placed in the storage module (1) from above. Here, the storage pins are positioned in the grooves of the storage modules intended for this purpose. For certain sizes, no storage pins can be attached to the exchangeable adapter; in these cases, an adapter plate (5) with the corresponding mounting pattern of the exchangeable adapter is required. The position adapter (4) can be used to store several tools per profile. Using the extension adapter (8), the distance to the profile can be increased, in order to store larger tools. The presence of the tool can be monitored with an inductive proximity switch (7).

CTS P

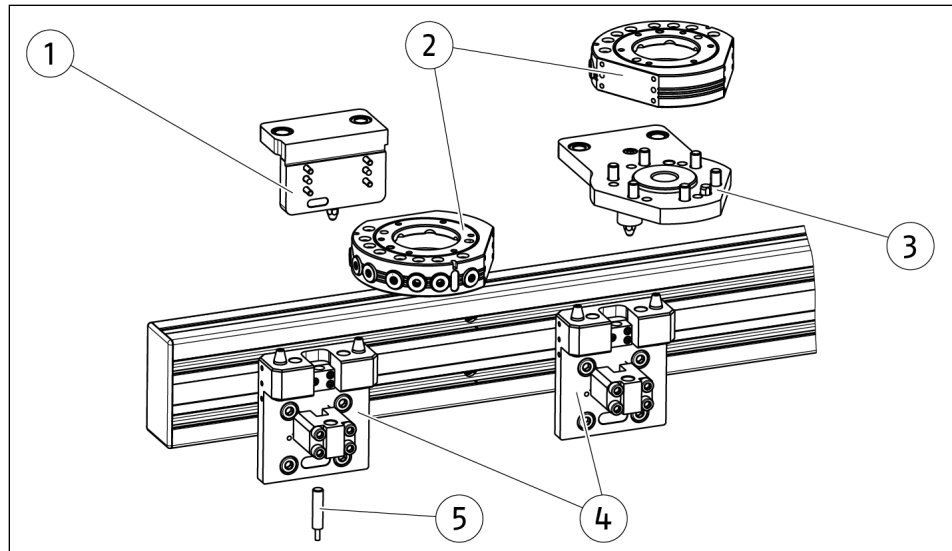

Storage module CTS P

- | | | |
|---|------------------------------|---|
| 1 | Adapter plate on the side * | (for mounting on the screw-on surface of the tool) |
| 2 | Tool | |
| 3 | Adapter plate below * | (for mounting as an intermediate plate between the tool and end effector) |
| 4 | Storage module | |
| 5 | Inductive proximity switch * | |

* Available as an accessory from SCHUNK. See the catalog data sheet for more information.

The tool is positioned precisely using a 3-point support. Pins and bolts are integrated in the storage module (3) and in the adapter plates (1, 2) for this purpose. Adapter plates are available in horizontal or vertical versions. The horizontal adapter plate (2) is mounted on the floor side of the tool (5). The vertical adapter plate (1) is attached to the side of the tool (5) or to another suitable point on the customer's tool using the screw connection diagram for the option modules. The presence of the change adapter can be checked with an inductive proximity switch (4).

CTS B

Information on the storage module CTS B can be found in the "Storage module CTS B" Assembly and Operating Manual.

5 Notes on mounting



⚠ WARNING

Risk of injury due to incorrect assembly!

If assembled incorrectly, the product may fall down, causing severe injuries.

- Observe the specified strength class, tightening torque and screw-in depth of the screws.
- Take suitable protective measures to secure the danger zone.
- Wear suitable protective equipment.
- Regularly check the fastening of the product.

Thread	Tightening torque [Nm]		
	Strength class		
	8.8	10.9	12.9
M3	1.2	1.8	2.1
M4	3.1	4.5	5.3
M5	6.1	9	11
M6	10	15	18
M8	25	37	43
M10	49	72	85

Tab.: Tightening torque for mounting screws

The modular storage rack CTS offers various mounting options for the storage modules, which can be used to store the interchangeable adapter with mounted tools.

- Storage modules can be mounted horizontally or vertically, depending on the application.
- Optional accessories are available from SCHUNK for each storage module, e.g. profile superstructures, adapter plates, proximity switches for monitoring the presence of the interchangeable adapters.
- Assembly examples, individual drawings with dimensions and information on accessories can be found in the catalog data sheet at [schunk.com](https://www.schunk.com).
- Detailed installation instructions for the storage module CTS B can be found in the separate "Storage module CTS B" Assembly and Operating Manual.

6 Troubleshooting

Problem	Possible cause	Corrective action
Tool storage position cannot be repeated.	Tool storage pin could be loose or missing.	Tighten or replace the storage pin if necessary.
	Tool changer is not correctly aligned with the storage module.	Check the tool changer and slots for damage or signs of wear due to misalignment. Realign if necessary.
The proximity switch fails.	Contamination has accumulated on the proximity switch.	Check the proximity switch for contamination and clean if necessary.
	The proximity switch is loose or not positioned correctly.	Check the distance between the sensor surface and the target and ensure that the sensor is correctly aligned with the target. Adjust if necessary.
	The sensor cable is broken or damaged.	Check sensor cable for damage, test continuity and replace if damaged.
	The proximity switch is damaged or is not functioning.	Check and test the proximity switch for damage.

7 Maintenance

7.1 Maintenance intervals

Maintenance interval	Maintenance work
monthly	Check the storage module for damage and wear, clean if necessary.

8 Disassembly and disposal



⚠ WARNING

Risk of injury due to unexpected movements!

If the power supply is switched on or residual energy remains in the system, components can move unexpectedly and cause serious injuries.

- Before starting any work on the product: Switch off the power supply and secure against restarting.
 - Make sure, that no residual energy remains in the system.
-
- Disconnect the entire energy supply from the product, discharge any accumulated residual energy.
 - Remove any lubricant and dispose of in an environmentally friendly manner.
 - Follow local regulations on dispatching product components for recycling or proper disposal.

9 Certificate of Conformity

Manufacturer/
Distributor SCHUNK SE & Co. KG
Spanntechnik | Greiftechnik | Automatisierungstechnik
Bahnhofstr. 106 – 134
D-74348 Lauffen/Neckar

We hereby declare on our sole authority that the product meets the requirements of the following directives at the time of the declaration.

The declaration is rendered invalid if modifications are made to the product.

Product designation: Modular storage rack / CTS /
ID number: 1594527, 1594541, 1594542, 1594543, 1594544, 1594545, 1594547,
1594549

Applicable directives:

2001/95/EC General product safety

Applied harmonized standards, especially:

EN ISO 12100:2010 Safety of machinery – General principles for design –
Risk assessment and risk reduction

Person authorized to compile the technical documentation:
Stefanie Walter, Address: see manufacturer's address

Signature: see original declaration

Dr.-Ing. Manuel Baumeister,
Head of Systems Engineering,
Technology & Innovation

Lauffen/Neckar, June 2025

10 Information on the RoHS Directive, REACH Regulation and Substances of Very High Concern (SVHC)

RoHS Directive

SCHUNK products are classified as "large-scale stationary installations" or as "large-scale stationary industrial tools" within the meaning of Directive 2011/65/EU and its extension 2015/863/EU "on the restriction of the use of certain hazardous substances in electrical and electronic equipment (RoHS)", or fulfill their intended function only as part of one. Therefore products from SCHUNK do not fall within the scope of the directive at this time.

REACH Regulation

Products from SCHUNK fully comply with the regulations of Regulation (EC) No. 1907/2006 "concerning the Registration, Evaluation, Authorization and Restriction of Chemicals (REACH)" and its amendment 2022/477. SCHUNK attaches great importance to completely avoiding chemicals of concern to humans and the environment wherever possible.

Only in rare exceptional cases do SCHUNK products contain SVHC substances on the candidate list with a mass content above 0.1%. In accordance with Article. 33 (1) of Regulation (EC) No. 1907/2006, SCHUNK complies with its duty to "communicate information on substances in articles" and lists the components concerned and the substances used in an overview that can be viewed at [schunk.com\SVHC](https://www.schunk.com/SVHC).

Signature: see original declaration

Dr.-Ing. Manuel Baumeister,
Head of Systems Engineering,
Technology & Innovation

Lauffen/Neckar, June 2025

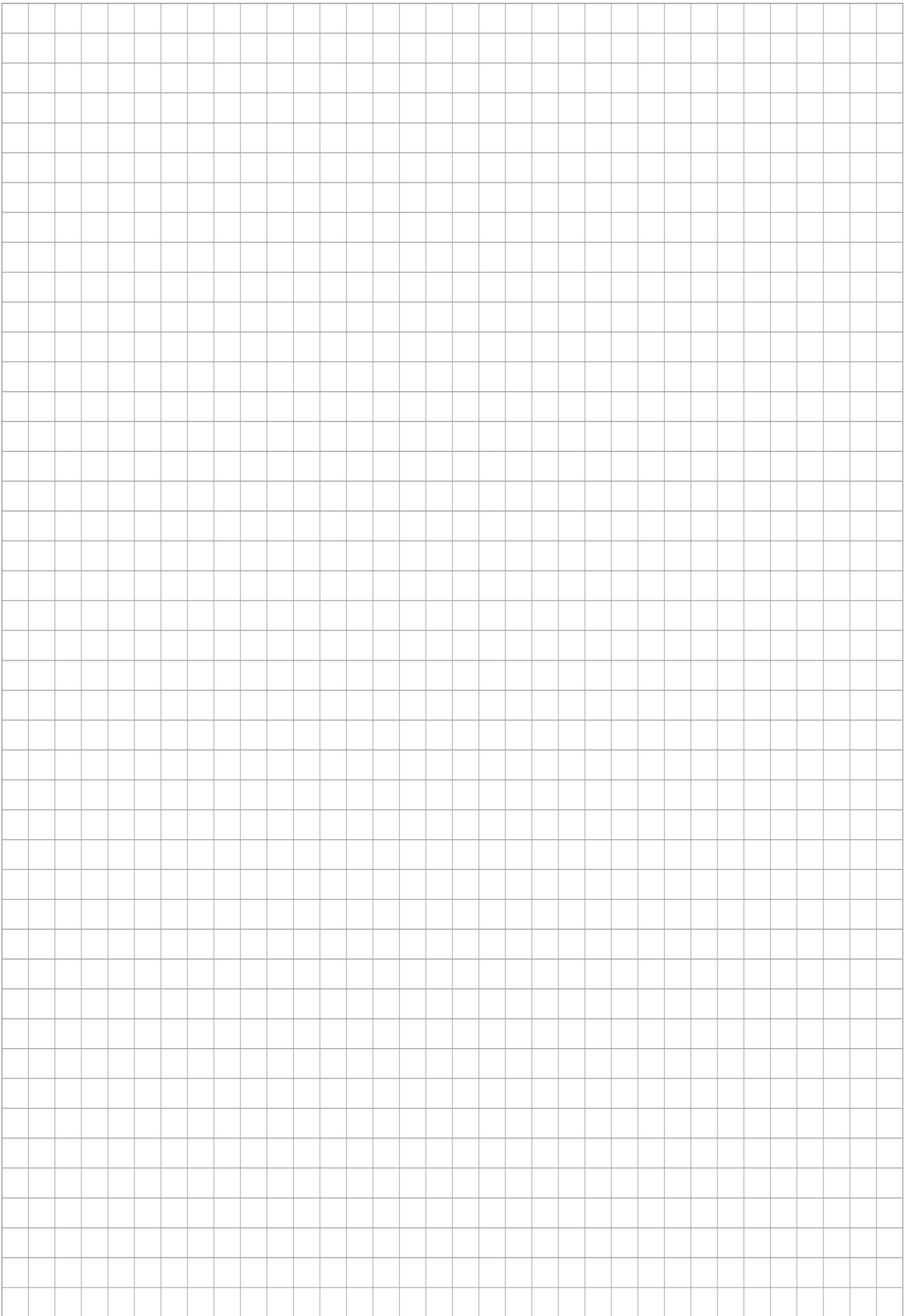



SCHUNK SE & Co. KG
Spanntechnik | Greiftechnik | Automatisierungstechnik

Bahnhofstr. 106 - 134
D-74348 Lauffen/Neckar
Tel. +49-7133-103-0
info@de.schunk.com
schunk.com

Folgen Sie uns | *Follow us*



Wir drucken nachhaltig | *We print sustainable*