

## Quick-change pallet system

# VERO-S NSL3 mini 100-25 Clamping stations

## Assembly and Operating Manual

## Imprint

### Copyright:

This manual is protected by copyright. The author is SCHUNK SE & Co. KG.  
All rights reserved.

### Technical changes:

We reserve the right to make alterations for the purpose of technical improvement.

**Document number:** 1635135

**Version:** 01.00 | 22/09/2025 | en

Dear Customer,

Thank you for trusting our products and our family-owned company, the leading technology supplier of robots and production machines.

Our team is always available to answer any questions on this product and other solutions. Ask us questions and challenge us. We will find a solution!

Best regards,

Your SCHUNK team

Customer Management

Tel. +49-7572-7614-1300

Fax +49-7572-7614-1039

cmm@de.schunk.com



**Please read the operating manual in full and keep it close to the product.**

## Table of Contents

<b>1 General .....</b>	<b>5</b>
1.1 About this manual.....	5
1.1.1 Illustration of safety notes .....	5
1.1.2 Applicable documents .....	6
1.2 Warranty .....	6
1.3 Scope of delivery.....	6
1.3.1 Accessories .....	6
<b>2 Basic safety notes.....</b>	<b>7</b>
2.1 Appropriate use .....	7
2.2 Inappropriate use .....	7
2.3 Structural changes.....	7
2.4 Spare parts .....	8
2.5 Ambient conditions and operating conditions .....	8
2.6 Material limitations .....	8
2.7 Personnel qualification .....	8
2.8 Personal protective equipment .....	9
2.9 Transport.....	9
2.10 Protection during handling and assembly .....	9
2.11 Protection during commissioning and operation .....	10
2.12 Notes on safe operation.....	10
2.13 Disposal .....	10
2.14 Fundamental dangers .....	11
2.15 Protection against dangerous movements .....	11
2.16 Notes on particular risks .....	11
<b>3 Technical data .....</b>	<b>13</b>
3.1 Suitability for welding applications .....	13
<b>4 Design.....</b>	<b>14</b>
4.1 Components of a clamping station .....	14
4.2 Design .....	14
<b>5 Assembly.....</b>	<b>15</b>
5.1 Screw tightening torques .....	15
5.2 General assembly instructions.....	15
5.3 Aligning the clamping station .....	16
5.4 Mounting the clamping stations .....	16
5.4.1 NSL3 mini 100-25-V1 clamping station.....	18
5.4.2 NSL3 mini 100-25-2 clamping station.....	18
5.4.3 NSL3 mini 100-25-4 clamping station.....	19

5.4.4	Alignment and mounting points.....	20
5.5	Connections .....	21
5.5.1	Unlocking connection.....	22
5.5.2	Turbo connection .....	22
5.6	SPA mini 20, SPB mini 20, SPC mini 20 clamping pins.....	23
<b>6</b>	<b>Maintenance and care .....</b>	<b>26</b>
6.1	Ambient conditions and operating conditions .....	26
6.2	Disassembling and assembling the clamping station.....	27
6.3	Control of proper function.....	28
6.4	Leak test .....	28
<b>7</b>	<b>Troubleshooting.....</b>	<b>29</b>
<b>8</b>	<b>Storage.....</b>	<b>30</b>
<b>9</b>	<b>Sealing kits and parts lists.....</b>	<b>31</b>
9.1	Sealing Kit List.....	31
9.2	Parts list.....	31
<b>10</b>	<b>Drawings .....</b>	<b>33</b>
<b>11</b>	<b>Manufacturer certificate.....</b>	<b>36</b>

# 1 General

## 1.1 About this manual

This manual contains important information for the safe, correct use of the product.

It is an integral part of the product and must be kept accessible for personnel at all times.

Personnel must have read and understood this manual before beginning any work. The observance of all safety notes in this manual is a prerequisite to ensure safe work processes.

The illustrations are intended to provide a basic understanding and may deviate from the actual version.

Besides this manual, other documents which apply are those listed under ▶ 1.1.2 [ 6 ]

### 1.1.1 Illustration of safety notes

To make risks clear, the following signal words and symbols are used for safety notes.



#### **⚠ DANGER**

Denotes a hazard with a high degree of risk that, if not avoided, will result in death or serious injury.



#### **⚠ WARNING**

Denotes a hazard with a medium degree of risk that, if not avoided, could result in death or serious injury.



#### **⚠ CAUTION**

Denotes a hazard with a low degree of risk that, if not avoided, could result in a minor or moderate injury.

#### **NOTICE**

Information about avoiding material damage.

### 1.1.2 Applicable documents

- General Terms and Conditions \*
- Catalog data sheet for the attached product \*
- Technical data sheet for optional attachments \*
- Approval drawings

The documents labeled with an asterisk (\*) can be downloaded from **schunk.com**.

## 1.2 Warranty

The warranty for standard products is 24 months from the date of delivery from the factory, or 50,000 cycles\* for manually operated clamping devices and 500,000 cycles\* for power operated clamping devices. For special clamping devices, it is 12 months from the date of delivery from the factory, assuming appropriate use in accordance with the following conditions:

- Observe the applicable documents, ▶ 1.1.2 [ 6]
- Observance of the ambient conditions and operating conditions
- Observe the care and maintenance instructions

Parts touching the workpiece and wearing parts are not covered by the warranty.

\* One cycle comprises one complete clamping procedure ("opening" and "closing").

## 1.3 Scope of delivery

### Clamping station NSL3 mini 100-25

Clamping station including quick-change pallet system in the version ordered. The scope of delivery also includes the required air connections and the appropriate locking coupling for operating the clamping station. Depending on the items ordered it may also contain components that are not fitted for transportation reasons.

### 1.3.1 Accessories

(when ordered separately – see catalog or data sheets)

- Clamping pallets Type PAL mini
- Module height extensions, mini
- Clamping devices height extensions, mini
- Clamping pin types SPA 20 mini, SPB 20 mini, SPC 20 mini
- Clamping pin extensions, mini
- Protective cover type SDE mini
- Clamping pin blank (BRR mini 40)

## 2 Basic safety notes

Improper handling, assembly and maintenance of this product may result in risk to persons and equipment if this operating manual is not observed.

### 2.1 Appropriate use

- This product and the compatible add-on components are intended for positioning and clamping workpieces or clamping pallets on machine tools.
- The product may only be used within the scope of its technical data.
- The product is intended for industrial and commercial use.
- Appropriate use of the product includes compliance with all instructions in this manual.
- Clamping of pallets and workpieces with temperatures between 0°C and 100°C, with clamping devices for higher temperatures (HT variant) up to 200°C.

### 2.2 Inappropriate use

The product is not being used appropriately if:

- the product is used as a pressing tool, a toolholder, a load-handling device or as lifting equipment.
- the technical data specified are exceeded during usage.
- the clamping pin or clamping ring is not mounted properly.
- the product is used for turning applications over 100 RPM without consulting SCHUNK.
- the product is not fully covered by the pallet, the fixture or the workpiece.
- the product is brought into contact with aggressive media, especially acids.
- the product is used in abrasive blasting processes, especially sandblasting.

### 2.3 Structural changes

#### Implementation of structural changes

Modifications, changes or reworking, e.g. additional threads, holes, or safety devices, can damage the product or impair its functionality or safety.

- Structural changes should only be made with the written approval of SCHUNK.

## 2.4 Spare parts

### Use of unauthorized spare parts

Using unauthorized spare parts can endanger personnel and damage the product or cause it to malfunction.

- Only use original spare parts and spares authorized by SCHUNK.

## 2.5 Ambient conditions and operating conditions

### Required ambient conditions and operating conditions

Incorrect ambient and operating conditions can make the product unsafe, leading to the risk of serious injuries, considerable material damage and/or a significant reduction in the service life of the product.

- Ensure that the product is only used within its technical data.
- Ensure that the product is of a sufficient size for the application.
- Ensure that the contact surfaces of the interface and recesses towards the locating surfaces above the mounting points are kept clean at all times.  
Prevent chips from entering the interface and cooling emulsion from filling the interface.
- Only use cooling emulsions with anti-corrosive additives when machining.
- When using the cone seal, protect it from direct high-pressure spraying with cooling emulsion.

## 2.6 Material limitations

The product is made of steel alloys, elastomers and aluminum alloys. In addition, Branotect anti-rust oil and Renolit HLT2 are incorporated into the product as auxiliary and operating materials.

## 2.7 Personnel qualification

### Inadequate qualification of personnel

Any work on the product by inadequately qualified personnel can lead to serious injuries and considerable material damage.

- All work must be performed by appropriately qualified personnel.
- Personnel must have read and understood the complete manual before beginning any work on the product.
- Observe country-specific accident prevention regulations and the general safety notes.

The following personnel qualifications are required for the various activities on the product:

<b>Qualified electrician</b>	Qualified electricians have the professional training, knowledge, and experience to work on electrical systems, to recognize and avoid potential dangers, and know the relevant standards and regulations.
<b>Specialist personnel</b>	Specialist personnel have the specialized training, knowledge, and experience to perform the tasks entrusted to them, to recognize and avoid potential dangers, and know the relevant standards and regulations.
<b>Instructed person</b>	Instructed persons have been instructed by the operator regarding the tasks entrusted to them and the potential dangers of inappropriate behavior.
<b>Manufacturer's service personnel</b>	The manufacturer's service personnel have the specialized training, knowledge, and experience to perform the work entrusted to them and to recognize and avoid potential dangers.

## 2.8 Personal protective equipment

### Use of personal protective equipment

Personal protective equipment serves to protect staff in the event of a danger that may interfere with their health or safety at work.

## 2.9 Transport

### Handling during transport

Incorrect handling during transport can make the product unsafe and risks the danger of serious injuries and considerable material damage.

- During transport and handling, secure the product to prevent it from falling.

## 2.10 Protection during handling and assembly

### Incorrect handling and assembly

Incorrect handling and assembly can make the product unsafe and can risk the danger of serious injuries and considerable material damage.

- All work must only be performed by appropriately qualified personnel.
- Secure the system against accidental operation during all work.
- Use suitable assembly and transport equipment and take precautions to prevent jamming and crushing.

## 2.11 Protection during commissioning and operation

### Falling or violently ejected components

Falling and ejected components can lead to serious injury or death.

- Take suitable protective measures to secure the danger zone.

### Manual loading

- If the clamping device is closed, the clamping pallet rests on the clamping slides after loading. When the clamping device is opened, the clamping pallet falls down. This poses a risk of crushing.

## 2.12 Notes on safe operation

### Incorrect manner of working by personnel

An incorrect manner of working can make the product unsafe and risks serious injuries and considerable material damage.

- Observe the safety notes and assembly instructions.
- Do not expose the product to any corrosive media. Products for special ambient conditions are excluded here.
- Do not expose the product to any media that lead to swelling or corroding of seals.
- Rectify malfunctions as soon as they occur.
- Observe the care and maintenance instructions.
- Observe the current safety, accident prevention, and environmental protection regulations for the application field of the product.
- The machine spindle must not be started until the clamping pressure in the clamping device has built up.
- Unclamping may only occur once the machine spindle has come to a standstill.

## 2.13 Disposal

### Handling of disposal

Incorrect handling of disposal can make the product unsafe and lead to risks of environmental harm.

- Follow local regulations on dispatching product components for recycling or proper disposal.

## 2.14 Fundamental dangers

### General

- Disconnect power sources before installation, modification, maintenance, or calibration. Ensure that no residual energy remains in the system.
- Do not reach into the open mechanism or movement area of the product during operation.

## 2.15 Protection against dangerous movements

### Safe condition

Quick-change pallet system with or without clamping pin clamped and without energy.

### Unexpected movements

If the system still retains residual energy, serious injuries can be caused while working on the product.

- Establish a safe state, switch off the energy supply, ensure that no residual energy remains and secure against inadvertent reactivation.

## 2.16 Notes on particular risks



### ⚠ WARNING

**Risk of injury due to falling device, pallet or workpiece if the clamping pin or clamping ring is loosened erroneously or as a result of negligence.**

- During operation, unintentional loosening of the clamping pin or clamping ring must be prevented by suitable countermeasures (implementation of the safety functions according to the risk assessment of the integrator).
- Wear personal protective equipment.



### ⚠ WARNING

**Risk of injury during commissioning due to a falling unlocked device, pallet or workpiece.**

- During loading, check that the coupling elements, devices, pallets or workpieces are positioned so they are aligned to each other.
- Clamping pallets with torque pin must be fed to the module in the correct orientation before locking.
- For modules with media transfer units, ensure the loading weight on the change interface is sufficient to ensure the surface of the interface is level with the module.



**⚠ WARNING**

**Risk of injury when the clamping pin or clamping ring axis is in a horizontal position or during overhead applications due to the device or pallet falling down.**

- Use a crane or a transport truck when transporting workpieces or clamping pallets.
- During horizontal or overhead applications, the device or clamping pallet must be secured before loosening to prevent it from falling.



**⚠ WARNING**

**The quick-change pallet system clamps using spring force. Risk of injury due to parts automatically moving to their end positions following actuation of an >>emergency stop<< or after switching off or failure of the power supply.**

- Wait for the system to come to a complete standstill in safe state.
- Do not reach into the clamping module.



**⚠ CAUTION**

**Risk of injury due to contamination (e.g. coolant or splashing water) in the blow-out and air purge connections of the clamping module or in the change interface.**

- Clean the quick-change pallet system before loading.
- Wear personal protective equipment (safety goggles).



**⚠ CAUTION**

**Risk of injury from pressurized media transfer unit interfaces. The actuated clamping device on top of these may move unexpectedly as a result.**

- Do not control the media transfer units until the device is clamped on the quick-change pallet systems.
- Take suitable protective measures to secure the danger zone.

### 3 Technical data

Operating temperature [°C]	5 – 60
Installation position	Any
Pressure medium	Compressed air, compressed air quality according to ISO 8573-1:2010 [7:4:4]
Minimum pressure [bar]	5 bar The operating pressure must not fall below 5 bar.
Actuating pressure [bar]	6
Maximum pressure [bar]	6
Repeatability [mm]	< 0.005
Noise emission [dB(A)]	≤ 70

Clamping station NSL3 mini			
Designation	100-25-V1	100-25-2	100-25-4
ID number	1618895	1618896	1618897
Holding force (M6 / M8)* [kN]	15 / 25	30 / 50	60 / 100
Pull-in force without turbo [kN]	1.5	3.0	6.0
Pull-in force with turbo [kN]	6.0	12.0	24.0
Weight [kg]	2.3	4.2	8.3

\* Holding force when fastening the clamping pin with cylindrical screw – DIN EN ISO 4762/12.9

**A separate maintenance unit with oiler must be used for the air supply.**

**Further technical information can be found in the catalog data sheets of the standard products used and the operating instructions of the modules used ▶ 1.1.2 [6].**

#### 3.1 Suitability for welding applications

The clamping device can be used for welding applications with a **welding current of up to 525 A**. The welding current is allowed to flow through the clamping device.

#### NOTICE

**In welding applications, special care must be taken to ensure that the operating temperature of the clamping device is not exceeded due to heat conduction in the workpiece.**

#### NOTICE

**The contact surfaces of the workpiece and the clamping bolt must always be kept clean to ensure the best possible contact with the clamping device.**

**If the quick-change pallet system is to be used outside the specified welding currents, please contact your SCHUNK contact person.**

## 4 Design

### 4.1 Components of a clamping station

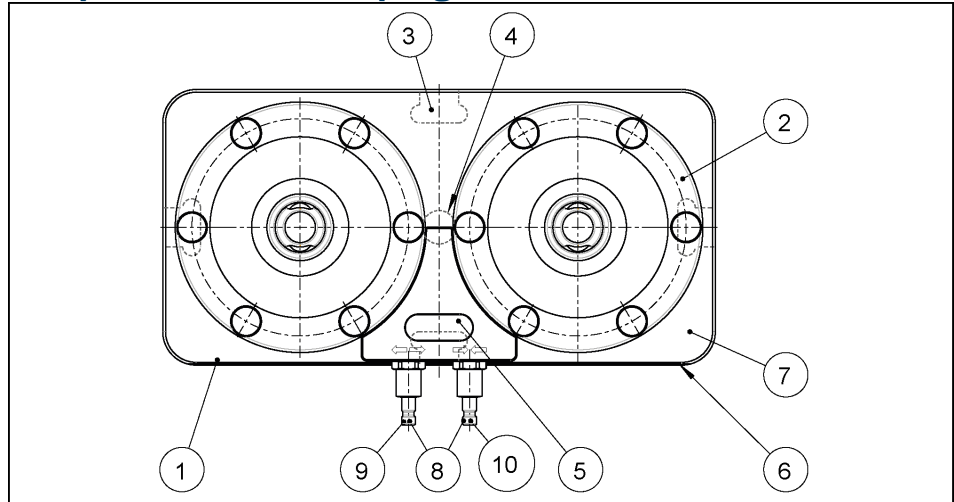

- 1 Base plate

---

- 2 Quick-change pallet module

---

- 3 Bottom side alignment grooves for T-nuts

---

- 4 Bottom side center holes for multiple clamping stations

---

- 5 Name plate

---

- 6 Alignment edge

---

- 7 Clamping area for cylindrical clamp blank

---

- 8 Sealing nipple with air bleed screw

---

- 9 Unlocking connection

---

- 10 Air connection for turbo function

---

### 4.2 Design

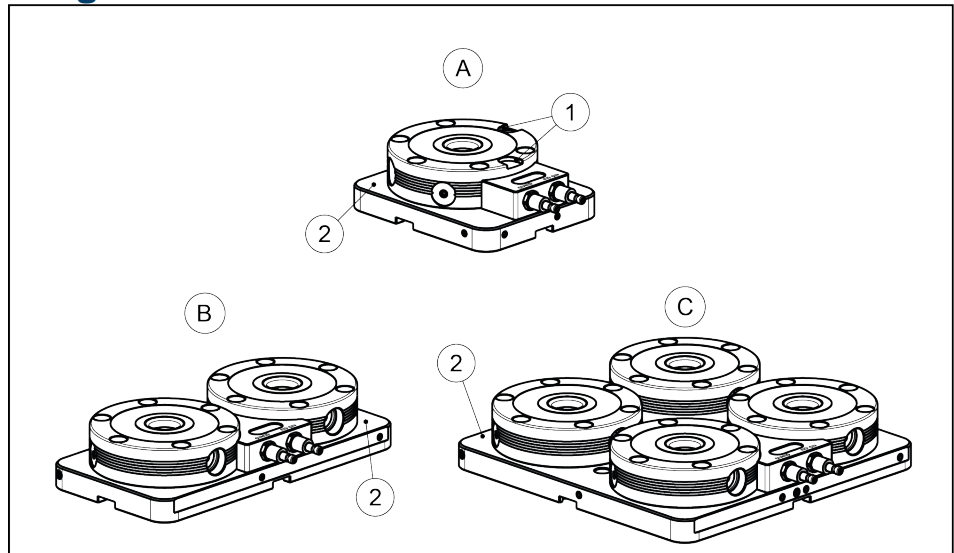

- A 1-way clamping station with torque pin type VI

---

- B 2-way clamping station

---

- C 4-way clamping station

---

- 1 Prism profile for positional alignment of the clamping pallet

---

- 2 Clamping area for cylindrical clamp blanks

---

## 5 Assembly

### 5.1 Screw tightening torques

#### Tightening torques for fastening the clamping station with the cylindrical clamp blanks.

The cylindrical clamps that have been adjusted by the customer to correspond to the machine table must be fastened to the machine table with fastening screws of strength class 10.9. These fastening screws and any nuts required for the T-slots are not included in the scope of delivery.

**Note:**

The clamping stations should preferably be fastened with M8 screws in connection with the cylindrical clamps.

#### Tightening torques for screw connections with screws according to ISO 4762 (strength class 10.9)

Screw size	M6	M8	M10	M12
Tightening torque (Nm)	13	28	50	88

#### Tightening torques for screw connections with screws according to ISO 4762 (strength class 12.9)

Screw size	M6	M8
Tightening torque (Nm)	15	32

### 5.2 General assembly instructions

For transport of the clamping station, we recommend the quick change clamping pins available as accessories. Eye bolts can be screwed into the inner threads of the clamping pins.

The quick change clamping modules of the clamping station are released with compressed air for insertion of the clamping pins.

#### NOTICE

**The air supply must be disconnected for transportation, so that the clamping pins remain locked.**

When connecting the Quick-Change Pallet Systems, please make sure that complete deaeration of the piston area during the locking operation is possible. Therefore, valves, sound absorbers or stop valves for deaeration should be available.

The same applies for the turbo connection. If the turbo connection will not be used, it must be possible that the relevant piston side can be deaerated.

When uncoupling the air hoses the corresponding openings have to be sealed with sealing plugs in order to prevent ingress of dirt or coolant into the module.

#### CAUTION

**Danger of injury due to sharp edges and rough or slippery surfaces**

- Wear personal protective equipment, particularly protective gloves.



### 5.3 Aligning the clamping station

The clamping station can be aligned with loose T-nuts along an aligning groove on the machine table. At least two T-nuts offset lengthwise are provided and their size is matched to the aligning groove on the machine table. The T-nuts are not included in the scope of delivery of the clamping station.

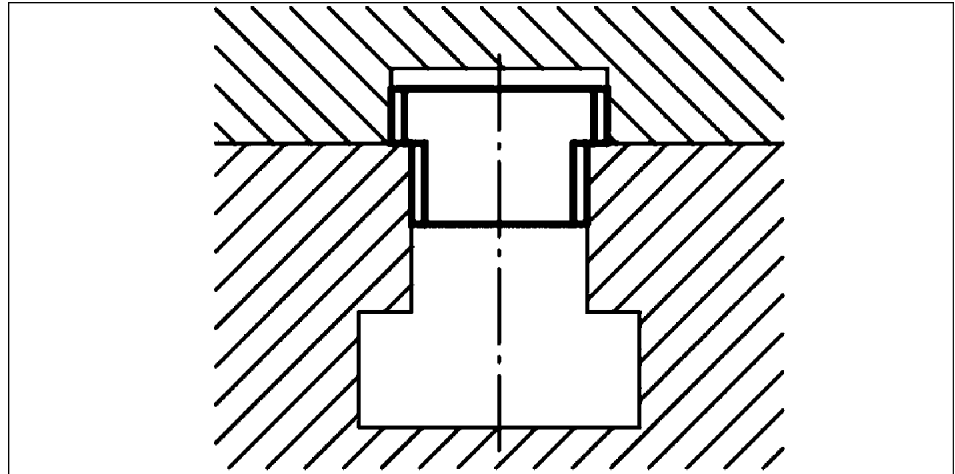

*Alignment using T-nuts*

### 5.4 Mounting the clamping stations

#### Flatness and distances

In order to assemble the clamping station, the clamping surface must have a flatness of  $\leq 0.03$  mm is required (based on the entire support areas of the clamping station). The clamping zone must have sufficient rigidity in order to ensure the relative flatness of the clamping modules. If several linked clamping stations are mounted, make sure that the flatness and height deviation of the locating surfaces from module to module (based on a 100 mm gauge for bore holes) is  $\leq 0.02$  mm. The gauge deviation between the separate clamping stations must not exceed  $\pm 0.015$  mm from module to module.

#### Redundancy

Due to redundancy, the clamping pins with positioning accuracy in one direction (SPB mini 20) should be used for clamping modules inside a clamping station or multiple linked clamping stations that are more than 160 mm apart or that do not show a positioning tolerance of  $\pm 0.01$  mm. For the clamping areas that are not intended for alignment of the device or pallet, clamping pins with centering clearance (SPC mini 20) can be used (also refer to chapter "Clamping pins" ▶ 5.6 [23]).

### Even height of the clamping modules

Even height of the clamping modules inside a clamping station is only ensured when in a clamped state. The clamping station is to be fastened with the BRR mini 40-15 clamp blanks which are available as accessories. The clamp blanks must be fastened with adequately dimensioned fastening screws in accordance with DIN EN ISO 4762 starting with thread size M8. The prescribed arrangement for the clamp blanks can be found in the following clamping diagram. The 4-way clamping station can also be screwed on the machine table with at least two M8 fastening screws. The mounting points are offset centrally between the clamping modules at a distance of 200 mm. Due to the additional screw fitting, increased rigidity on the machine table is achieved for the clamping station.

#### NOTICE

**The height of the modules will only be even once the clamping station has been properly mounted on the machine table.**

For the arrangement of the cylindrical clamp BRR mini 40-15, see the "Clamping range" illustration.

The clamping station NSL3 mini 100-25-4 also offers additional mounting options. See the descriptions of the clamping station types.

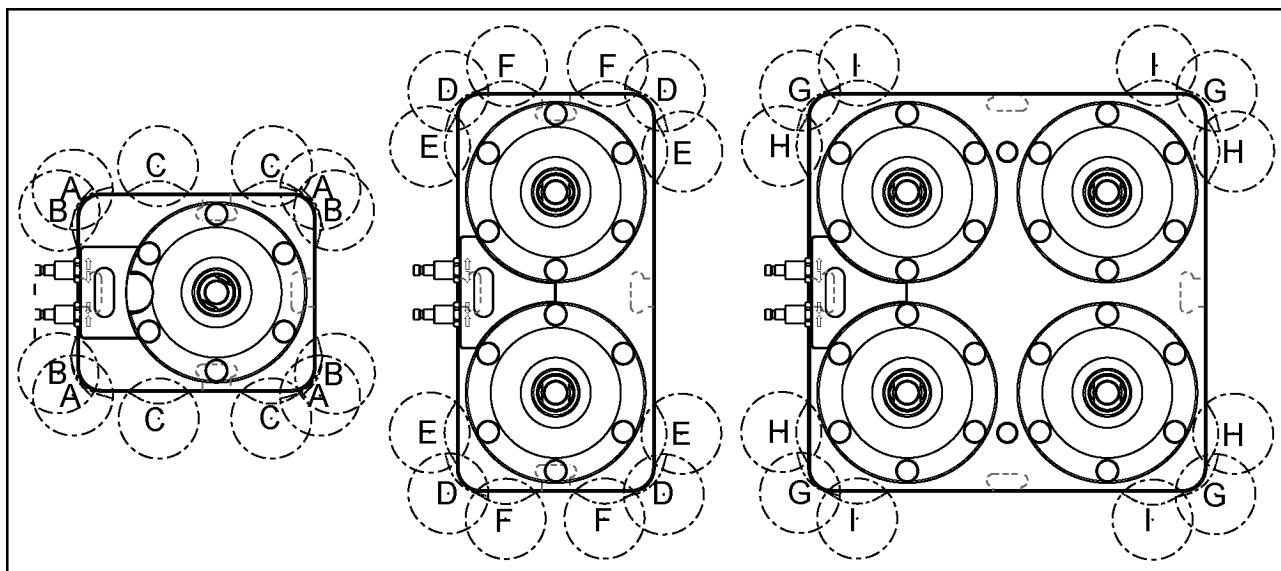

Clamping areas for mounting using cylindrical clamp blanks

NSL3 mini 100-25-V1	NSL3 mini 100-25-2	NSL3 mini 100-25-4
A / B / C	D / E / F	G / H / I

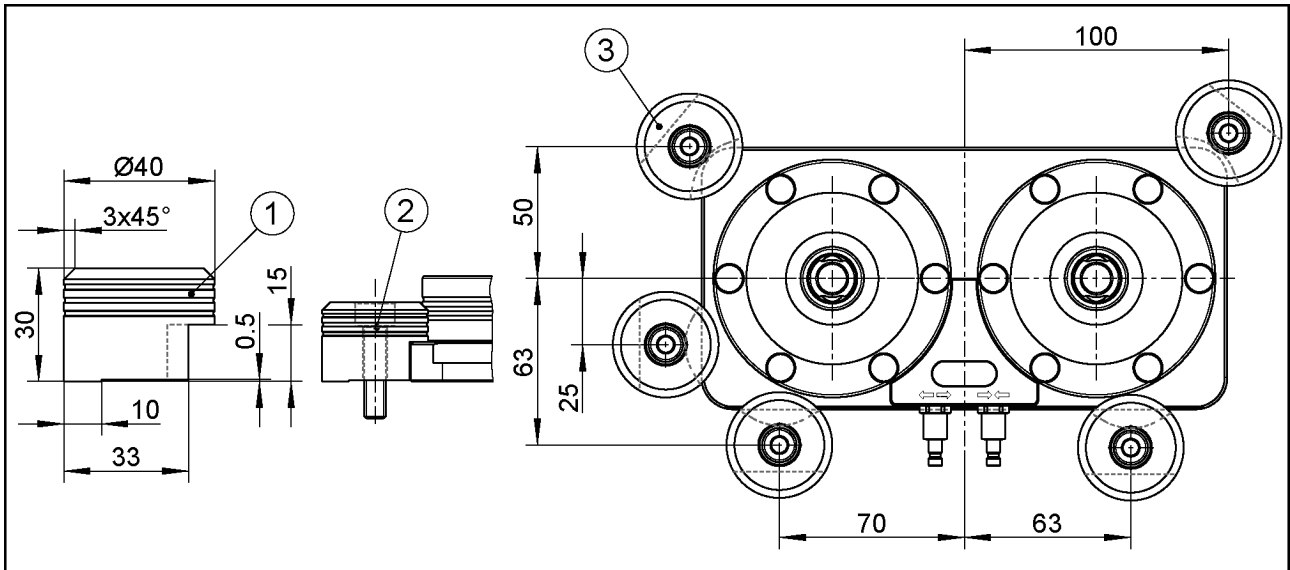

- 1 Cylindrical clamp blanks are versatile fastening elements
- 2 The mounting holes are machined by the customer
- 3 Flexible mounting options for all common slot spacings of the machine tables

#### 5.4.1 NSL3 mini 100-25-V1 clamping station

For alignment and mounting, see illustrations in the chapters "Design" ▶ 4 [14], "Mounting the clamping stations" ▶ 5.4 [17] and "Alignment and mounting points" ▶ 5.4.4 [20].

Alignment of the clamping stations on the machine table takes place via grooves for mounting T-nuts.

The clamping station is attached to the corners of the base plate using the four BRR mini 40-15 cylindrical clamp blanks included in the accessory kit. It must be mounted on at least 3 terminal points.

The cylindrical clamp blanks must be mounted with cylindrical screws according to DIN ISO 4762 with the strength class 10.9.

A through-hole can be drilled by the customer in the cylindrical clamp blanks for a fastening screw. To increase the clamping pressure, the screw hole must be positioned close to the inner indentation.

#### 5.4.2 NSL3 mini 100-25-2 clamping station

For alignment and mounting, see illustrations in the chapters "Design" ▶ 4 [14], "Mounting the clamping stations" ▶ 5.4 [17] and "Alignment and mounting points" ▶ 5.4.4 [20]. For the tightening torques required, see "Screw torques" chapter.▶ 5.1 [15]

Alignment of the clamping stations on the machine table takes place via grooves for mounting T-nuts.

The clamping station also has an alignment edge on the operator side. By scanning the alignment edge over a certain path length, the clamping station can be aligned parallel to the machine table.

A center hole for mounting an alignment bolt is available for center alignment of the clamping station.

The clamping station is fastened to the corners of the base plate using the four BRR mini 40-15 cylindrical clamp blanks included in the accessory kit. The cylindrical clamp blanks must be screwed using cylindrical screws according to DIN ISO 4762 with the strength class 10.9.

A through-hole can be drilled by the customer in the cylindrical clamp blanks for a fastening screw. To increase the clamping pressure, the screw hole must be positioned close to the inner indentation.

### 5.4.3 NSL3 mini 100-25-4 clamping station

For alignment and mounting, see illustrations in the chapters "Design" ▶ 4 [14], "Mounting the clamping stations" ▶ 5.4 [17] and "Alignment and mounting points" ▶ 5.4.4 [20]. For the tightening torques required, see "Screw torques" chapter. ▶ 5.1 [15]

Alignment of the clamping stations on the machine table takes place via grooves for mounting T-nuts.

The clamping station also has an alignment edge on the operator side. By scanning the alignment edge over a certain path length, the clamping station can be aligned parallel to the machine table.

A center hole for mounting an alignment bolt is available for center alignment of the clamping station.

The clamping station is attached to the corners of the base plate using the four BRR mini 40-15 cylindrical clamp blanks included in the accessory kit. The cylindrical clamp blanks must be mounted with cylindrical screws according to DIN ISO 4762 with the strength class 10.9.

A through-hole can be drilled by the customer in the cylindrical clamp blanks for a fastening screw. To increase the clamping pressure, the screw hole must be positioned close to the inner indentation.

The 4-way clamping station can also be screwed on the machine table with at least two M8 fastening screws.

### 5.4.4 Alignment and mounting points

#### Alignment elements and mounting points for the NSL3 mini 100-25-V1

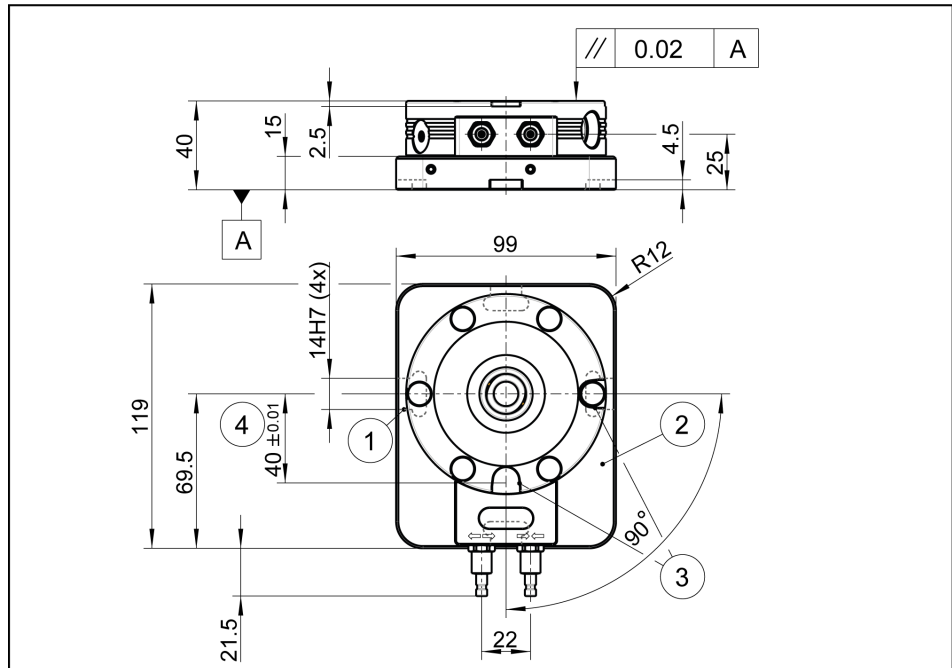

- 1 T-slot holder (4x) for alignment on the machine table
- 2 Clamping areas for the cylindrical clamps BRR mini 40-15
- 3 Prism profile for positional alignment of the clamping pallet
- 4 Measure of clearance for IXB V1 PAL mini in the clamping pallet

#### Alignment elements and mounting points for the NSL3 mini 100-25-2

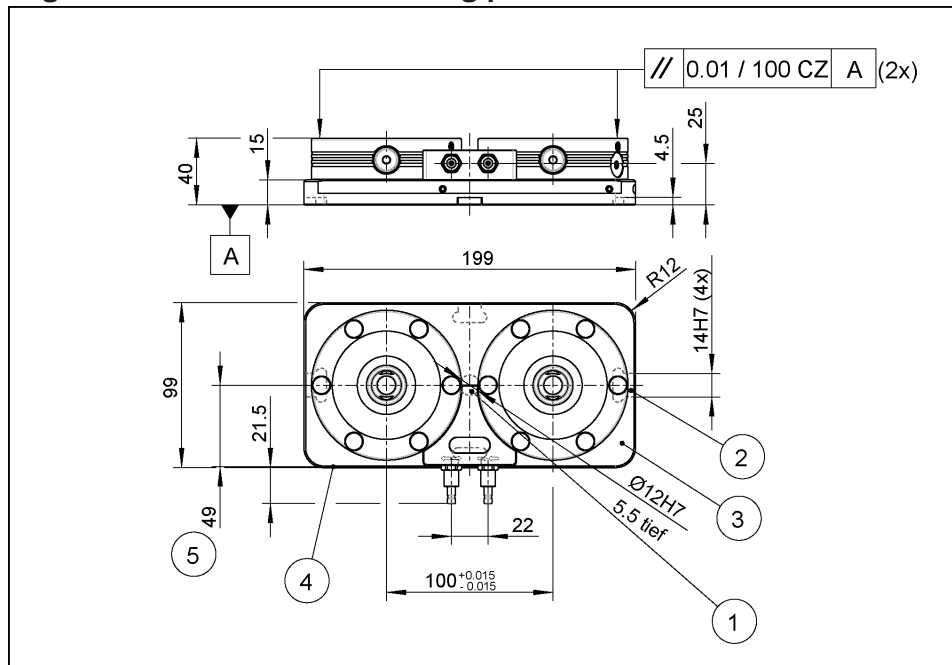

- 1 Centering bore for alignment pin
- 2 T-slot holder (4x) for alignment on the machine table
- 3 Clamping areas for the cylindrical clamps BRR mini 40-15
- 4 Alignment edge as an alignment tool for mounting
- 5 Measure of clearance for alignment edge

### Alignment elements and mounting points for the NSL3 mini 100-25-4

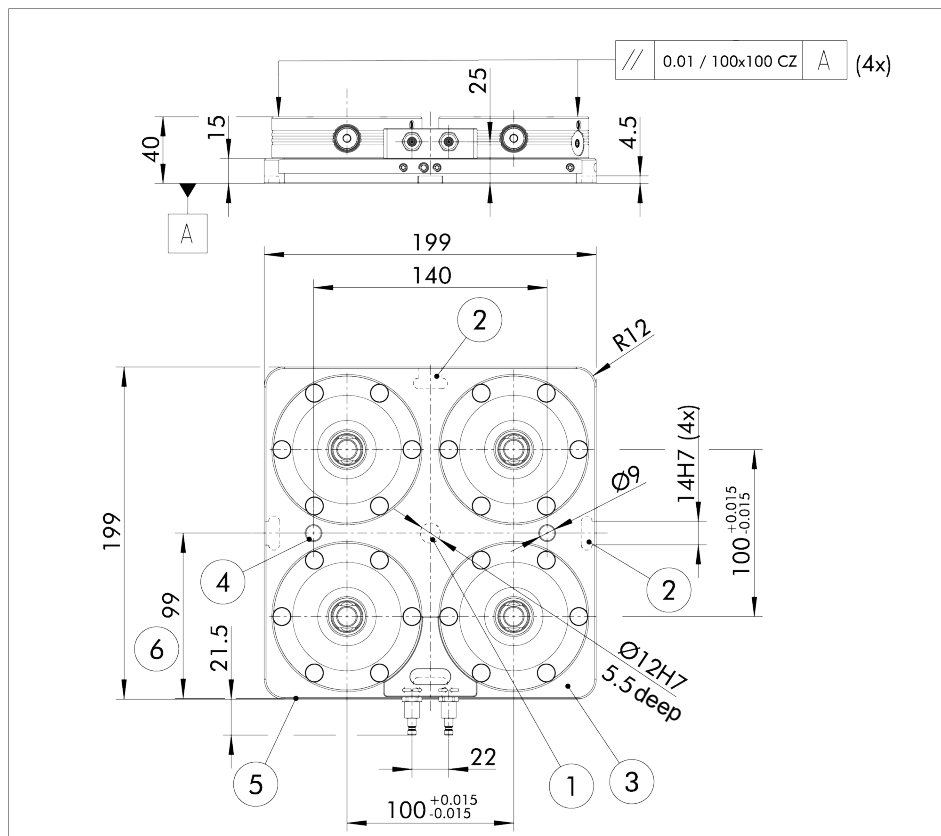

- 1 Centering bore for alignment pin
- 2 T-slot holder (4x) for alignment on the machine table
- 3 Clamping areas for the cylindrical clamps BRR mini 40-15
- 4 Additional mounting points for mounting with screws (2x)
- 5 Alignment edge as an alignment tool for mounting
- 6 Measure of clearance for alignment edge

## 5.5 Connections

The clamping stations are equipped with two air connections. There is a sealing nipple for NW 2.7 mm quick couplings at the air connections. One air connection provides the control for unlocking the quick-change pallet module. The other air connection is intended for the turbo function. The sealing nipples are equipped with a bleeding function for bleeding the pressure chambers of the quick-change pallet module. A locking coupling with connection thread G1/8" is included in the scope of delivery.

### NOTICE

**When using customer systems, a sealing nipple without a shut-off function is to be used. The chambers in the modules must be ventilated on actuation.**

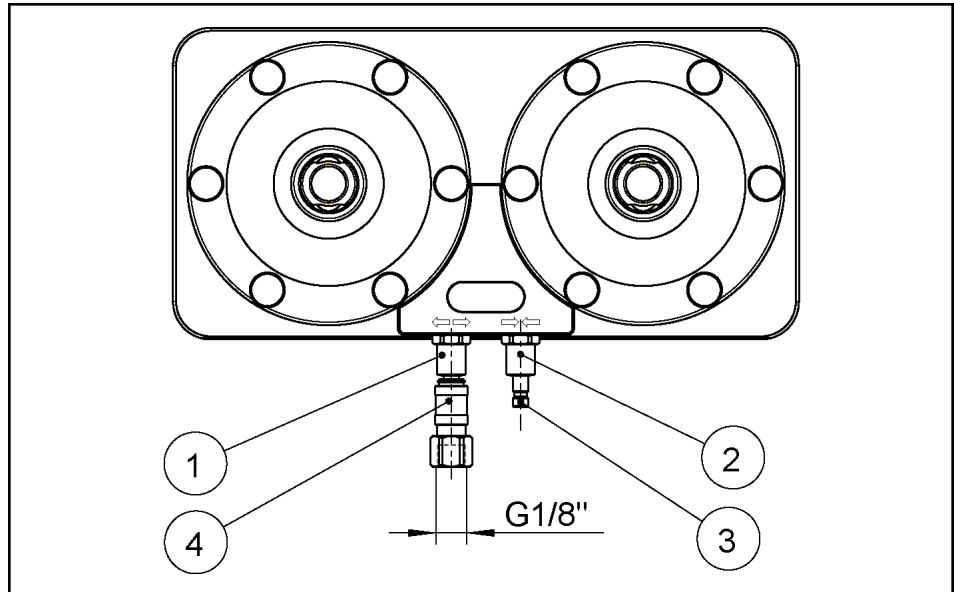

- 1 Unlocking connection

---

- 2 Connection for turbo function

---

- 3 Sealing nipple

---

- 4 Locking coupling

### 5.5.1 Unlocking connection

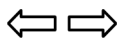

When the unlocking connection of the clamping station is actuated with compressed air, all of the modules are unlocked simultaneously.

Clamping pallets, devices and workpieces can be inserted in and removed from the clamping station.

### 5.5.2 Turbo connection



The clamping station comes standard with a turbo connection. When compressed air is applied, this actively provides air pressure to support the spring-actuated locking procedure. This increases the pull-down force simultaneously in all the modules. The increase in the pull-down force on the clamping modules is achieved with a pressure pulse at the air connection. After actuation of the turbo function, the compressed air supply can be disconnected again, the increased pull-down force is retained.

## 5.6 SPA mini 20, SPB mini 20, SPC mini 20 clamping pins

### NOTICE

#### Notes on clamping pins and mounting screws

The holding force of the quick-change pallet system is limited essentially by the tightness of the screw connection which connects the clamping pin to the pallet or the device. This is why only screws of strength class 12.9 may be used.

- Only original SCHUNK clamping pins may be used.
- If the clamping pins are to be used in customer-owned devices, the customer must provide sufficiently dimensioned threaded holes or a sufficiently thick mounting material.

The clamping pins can be attached to the workpiece or pallet in two different ways.

Preference should be given to the left mounting option in the illustration "Mounting the clamping pins". With this variant, if there is a module failure then the device or pallet can be removed after disassembling the clamping pins.

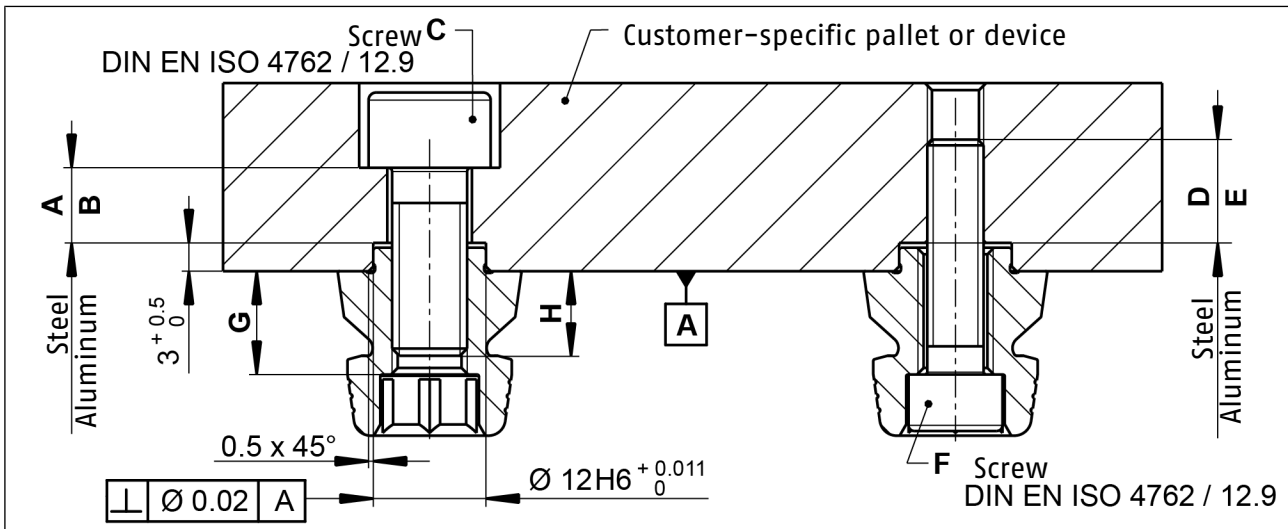

Mounting the clamping pins

#### Tolerances and installation conditions

Type	ID	A [mm]	B [mm]	C	D [mm]	E [mm]	F	G* [mm]	H [mm]
SPA mini 20	0435610	> 8	> 13	M8	> 9	> 11	M6	11	> 8
SPB mini 20	0435620	> 8	> 13	M8	> 9	> 11	M6	11	> 8
SPC mini 20	0435630	> 8	> 13	M8	> 9	> 11	M6	11	> 8

\* The length of the screwed thread must not exceed the dimension "G" under any circumstances!

## Usage/arrangement of the different types of clamping pins

Application: pallet with a clamping area

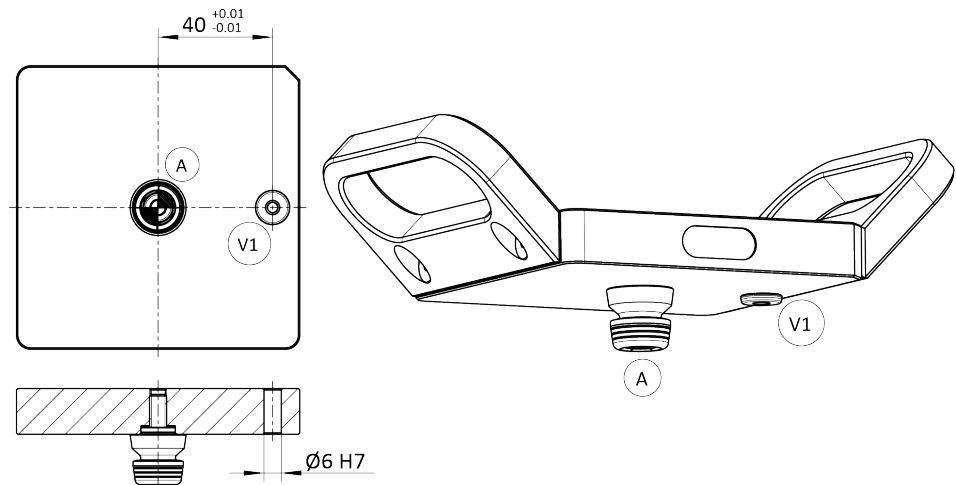

*Indexing pins installation dimensions type V1*

- |    |  |
|----|--|
| A  | Type A clamping pin with positioning accuracy  |
| V1 | Indexing pin for position orientation and torque transmission for VERO-S mini module with torque pin type V1 |

### Note

The indexing pin is intended for position orientation and torque transmission.

### Note

The clamping pallet of the type PAL S mini 99 x 99-V1 is equipped with one fitting bore for installing an indexing pin suitable for the clamping system. Mounting it on the respective quick-change pallet module requires installing the indexing pin included in the scope of delivery.

### Note

When using clamping pallets or clamping device elevations, it must be ensured that the indexing pin matching the clamping module is installed at the correct distance.

If necessary, a corresponding fitting bore must be drilled by the customer in order to be able to mount the indexing pin or if a specific angular alignment is required.

For conversion purposes, the indexing pins can be carefully knocked out of the clamping pallet or pulled out of the fitting bore using the extraction thread. It is important to ensure that the surface of the clamping pallet remains undamaged when removing and installing the indexing pins and that it is fully in contact on the bottom of the clamping pallet.

**Application: pallet with two clamping areas**

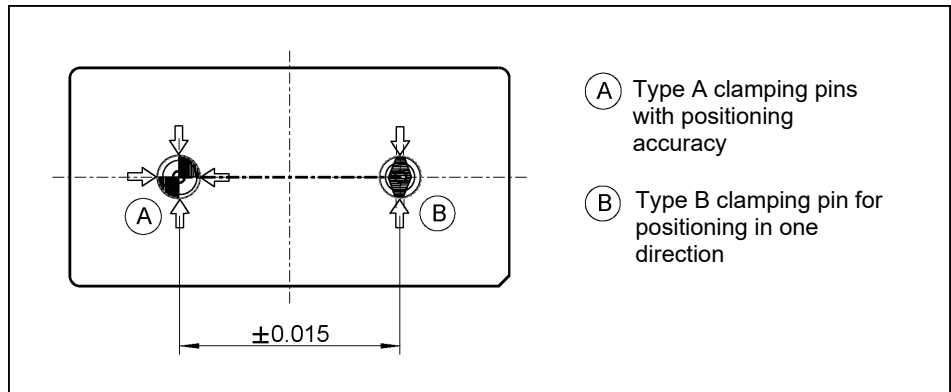

**Application: pallet with four clamping areas**

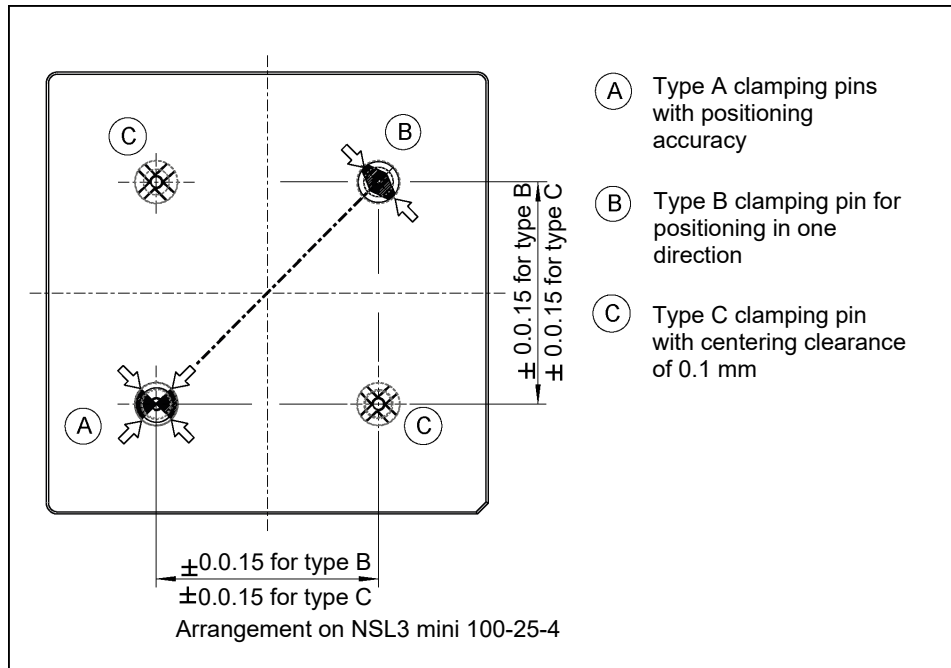

**Note**

If using clamping pallets or clamping device height extensions suitable for NSL3 mini 100-25-4, the clamping pins may differ from the illustration. Clamping pallets can be assembled from two coupled units. In this case, another arrangement of the clamping pin types is required. The arrangement of the clamping pin types must be checked against the specific clamping pallets used. A conversion according to the illustration above is then required to achieve the highest possible positional accuracy.

## 6 Maintenance and care

The clamping station is designed for low-maintenance operation. As such opening and disassembly of the clamping modules is only necessary in exceptional cases.



### ⚠ CAUTION

**Risk of injury and risk of damage to the pneumatic clamping modules when opening the modules.**

**If a pneumatic clamping module has to be disassembled, send the module to SCHUNK for repair.**

**The rear cover of the clamping module is spring preloaded and must only be removed and installed using a special installation tool by trained specialist personnel and in line with the appropriate removal and installation manual.**

**To ensure the quick-change pallet system operates perfectly, the following instructions must be observed:**

Pressure medium: Compressed air, compressed air quality according to ISO 8573-1:2010 [7:4:4]

### NOTICE

**A separate maintenance unit must be used for the air supply. The quick-change pallet system is designed for operation with dry compressed air. If oiled compressed air is used for operation, this must be done every time. The compressed air should be prepared with 1 to 2 drops of oil for an air volume of 1000 liters.**

### 6.1 Ambient conditions and operating conditions

- Make sure that the contact surfaces of the interface are always clean.
- Make absolutely sure that no chips of any kind can enter the interface and that the interface does not fill with cooling emulsion, which is particularly possible with vertical alignment of the clamping pin axis. The best way to ensure both of these is to use the SDE mini 20 or SDE mini 90 protection covers.  
If the interface should fill with cooling emulsion, initiate the unlocking process and dry out the interface in actuated state.
- Only use high-quality cooling emulsions with anti-corrosive additives during processing.
- Check the units at regular intervals (at least every two weeks or after 1000 clamping operations). The system is functioning correctly if the clamping slides move smoothly at minimum system pressure (5 bar).
- Carry out regular visual/functional checks. In case of visible damage or signs of malfunction, shut down the quick-change pallet system immediately. The system may only be started up again once the faults have been corrected, for instance by replacement of a damaged module.

## 6.2 Disassembling and assembling the clamping station

The item numbers specified for the corresponding individual components relate to the chapter Drawings, ▶ 10 [ 33].

When replacing wearing parts (e.g. seals), adhere to the following order:

1. Remove the clamping system from the machine table.
2. If necessary, remove the installed clamping module from the base plate (item 1). To disassemble the quick-change pallet module, the cover plugs of the fastening screws must be levered out. The fastening screws can be loosened and the clamping modules can be removed.
3. Remove the O-rings used in the clamping modules from the bottom O-ring fittings.
4. Remove the O-rings from the NSL3 mini 100-25-V1 installation fitting.
5. If necessary, remove the connection piece (item 2) from the base plate (item 1).
6. Remove the O-rings used in the connection piece from the bottom O-ring fittings.
7. If necessary, remove the air duct strips with seals from the bottom of the base plate in the NSL3 mini 100-25-4.
8. The NSL3 mini 100-25-4 set screws installed in the base plate (item 1) should only be unscrewed if necessary, allowing the tightness of the clamping system to be maintained. Screw in new set screws with thread sealant until pressure-tight.
9. Clean all the parts thoroughly and check for damage and wear. Damaged and worn parts must be replaced.

**Replace damaged parts with original SCHUNK spare parts only.**

To assemble the clamping station, complete the above procedure in reverse:

1. Grease the new seals with Renolit HLT 2 or an equivalent grease.
2. Mount the new seals carefully without causing damage.
3. Install the quick-change pallet module, tightening the fastening screws according to the torque specification ▶ 5.1 [ 15].
4. If necessary, install new seals on the bottom air duct strips, only tightening the fastening screws by hand.
5. Carry out a functional check and leak test.

### 6.3 Control of proper function

For the functional test, the proper functioning of the quick-change pallet systems should be tested.

The systems is working perfectly if:

- the clamping slide moves smoothly at minimum system pressure (5 bar).
- the desired functions correspond to the symbol on the clamping station housing.
- the clamping system shows no signs of leaking.

### 6.4 Leak test

As part of a leak test, the air and plug-in connections and the clamping station are tested for leaks.

Leaks must be sealed, for example at the plug-in connections or at the set-screws for duct sealing. Defective components must be replaced with new parts.

**The following components are required for the leak test: pressure gauge, supply line with coupling nipple.**

Performing the leak test:

1. Connect the components to the air connection in the following order:  
pressure gauge, supply line with locking coupling.
2. Pressurize the clamping system with compressed air.
3. Check the clamping system for tightness in both switch positions for module control. With the NSL3 mini 100-25-4, pay attention to the tightness of the air duct strips installed on the bottom.

To test the tightness of the clamping system, no clamping pallet should be fitted.

If the clamping system has leaks, check the entire pneumatic system (e.g. using Metaflux leak detector spray).

Leaks must be sealed, for example at the set-screws of the base plate or the plug-in connections.

If leaks in the seals or connections are found, check them and replace if worn or defective.

## 7 Troubleshooting

### The clamping area fails to unlock properly, or at all

Possible cause	Remedial measures
Pressure below minimum	Check operating pressure (min. 5 bar)
The clamping station was not operated with oiled compressed air	Install maintenance unit with oiler
Defective air connections	Check air supply
A component is broken (e.g. due to overloading)	Replace the module or send it to SCHUNK for repair
Excess tensile load on clamping pins	Reduce support weight
The turbo connection is still pressurized	Ventilate the connection
Leaky air supply or air connection	Check for leaks ▶ 6.4 [📄 28]

### The quick-change pallet systems no longer open quietly

Possible cause	Remedial measures
The clamping faces on the clamping slides and on the clamping pin are dirty	Remove the clamping pallet and clean the clamping faces on the clamping slides and on the clamping pins. Clean all clamping modules installed on the clamping slides

## 8 Storage

When storing the product for a longer period of time, observe the following points:

- Clean the product and lubricate it lightly.
- Store the product in a suitable transport container.
- Only store the product in dry rooms.
- Protect the product from major temperature fluctuations.

**NOTE:** Before recommissioning, clean the product and all attachments, check for damage, functionality and leaks.

## 9 Sealing kits and parts lists

When ordering spare parts, the type, size and, if possible, the serial number of the clamping system must always be stated to avoid delivery mistakes.

**Seals, sealing elements, fittings, springs, bearings, screws, wiper bars and parts that come into contact with the workpiece are not covered by the warranty.**

### 9.1 Sealing Kit List

Size / Sealing kit*	ID
NSL3 mini 100-25-V1	1648338
NSL3 mini 100-25-2	1648339
NSL3 mini 100-25-4	1648360

\* For included items, see note **X** in the Parts List chapter below. Seals are wearing parts and are recommended to be replaced during maintenance. The sealing kit can only be ordered as a complete kit.

### 9.2 Parts list

**NSL3 mini 100-25-V1** (ID 1618895)

Item	Designation	Quantity	Note
1	Base plate	1	
2	Connection piece	1	
3	NSE3 mini 90-25-V1	1	
5	O-ring	2	<b>X</b>
6	O-ring	2	<b>X</b>
7	O-ring	1	<b>X</b>
8	Cylindrical pin	1	
9	Screw	2	
14	Locking nipple	2	
15	Closure coupling	1	
16	Locking screw	2	
21	O-ring	3	<b>X*</b>

**NSL3 mini 100-25-2 (ID 1618896)**

Item	Designation	Quantity	Note
1	Base plate	1	
2	Connection piece	1	
3	NSE3 mini 90-25	2	
5	O-ring	2	<b>X</b>
6	Screw	2	
14	Locking nipple	2	
15	Closure coupling	1	
16	Locking screw	2	
21	O-ring	6	<b>X*</b>

**NSL3 mini 100-25-4 (ID 1618897)**

Item	Designation	Quantity	Note
1	Base plate	1	
2	Connection piece	1	
3	Air duct strip	4	
4	NSE3 mini 90-25	4	
6	Set-screw	12	
7	Set-screw	2	
8	O-ring	2	<b>X</b>
9	O-ring	4	<b>X</b>
10	O-ring	8	<b>X</b>
11	Countersunk screw	8	
12	Screw	2	
14	Locking nipple	2	
15	Closure coupling	1	
16	Locking screw	2	
21	O-ring	12	<b>X*</b>

**Parts list key**

**X** included in the sealing kit

**\*** Seal for installation in quick-change pallet system VERO-S NSE3 mini 90-25 and NSE3 mini 90-25-V1

## 10 Drawings

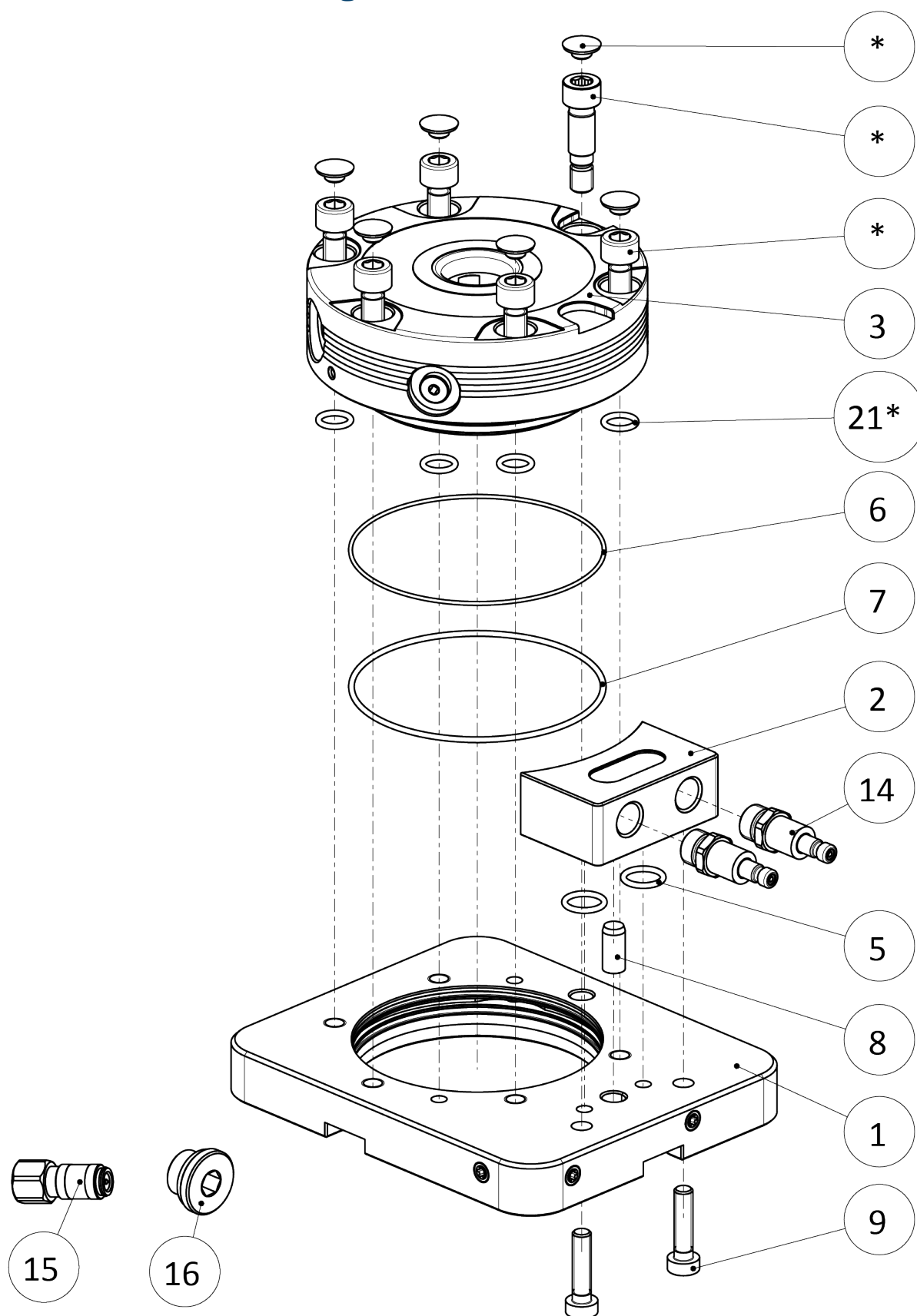

\* Scope of delivery for quick-change pallet system

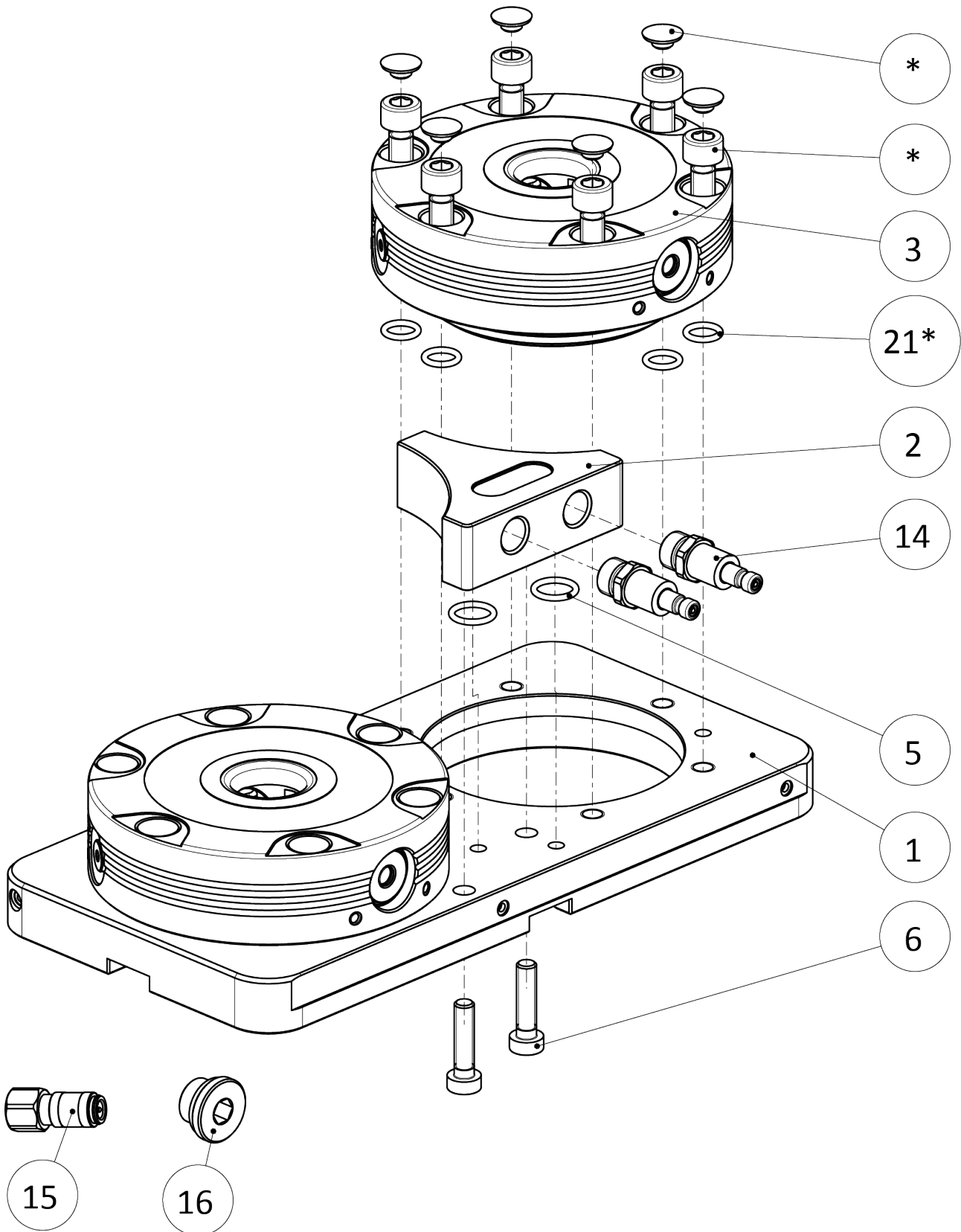

\* Scope of delivery for quick-change pallet system

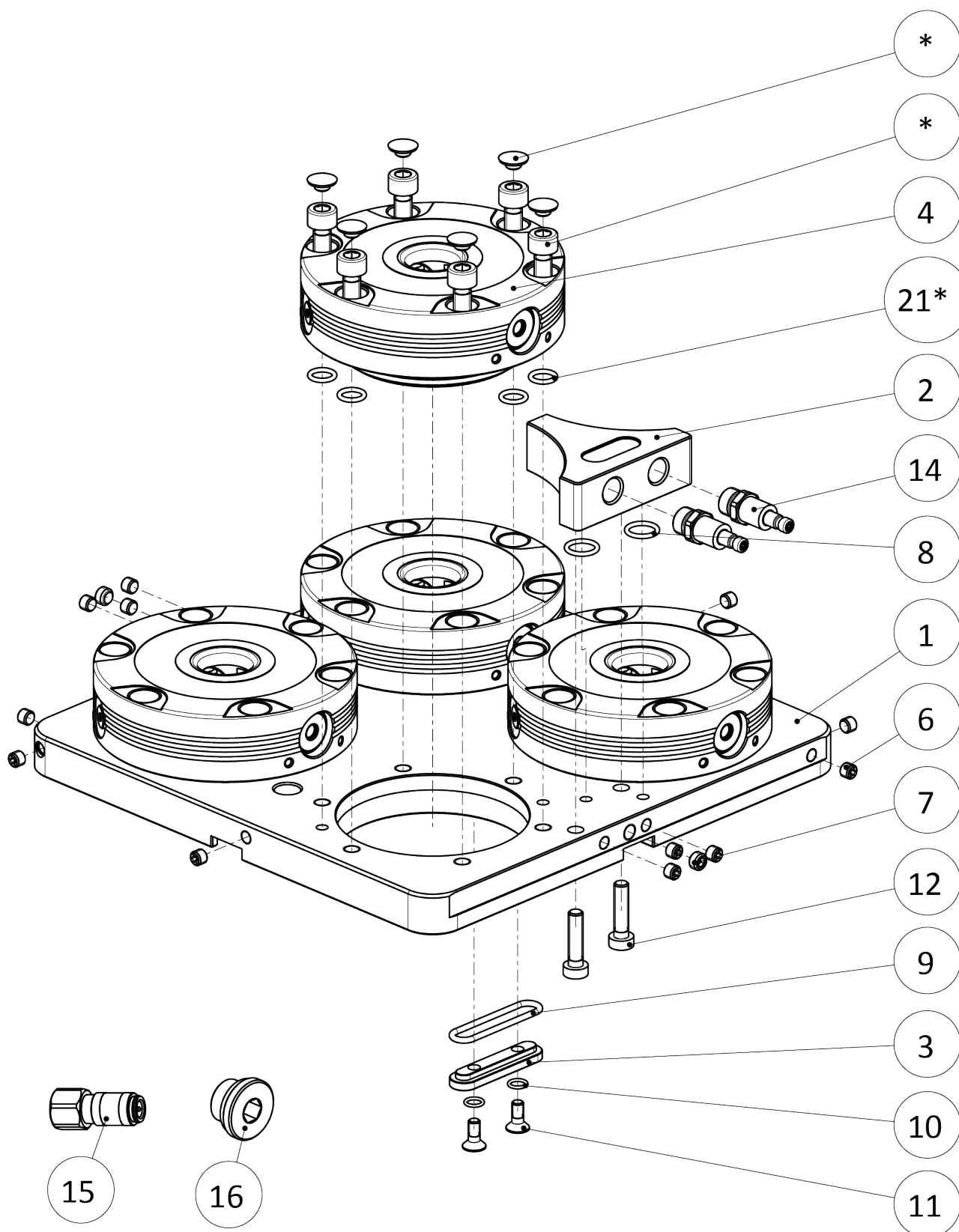

\* Scope of delivery for quick-change pallet system

## 11 Manufacturer certificate

Manufacturer / Distributor:	H.-D. SCHUNK GmbH & Co. Spanntechnik KG Lothringer Str. 23 D-88512 Mengen
Product:	Quick-change pallet system
Designation:	VERO-S
Type designation:	NSL, NSD, NST, GSL, SSN, SSN turn

**Heinz-Dieter SCHUNK GmbH & Co. Spanntechnik KG** certifies that the above-mentioned products, when used as intended and in compliance with the operating manual and the warnings on the product, are safe according to the national regulations and:

- a **risk assessment** has been carried out in accordance with ISO 12100:2010.
- an **operating manual** for the assembly instructions has been created in accordance with the contents of the Machinery Directive 2006/42/EC Annex I No. 1.7.4.2. and the contents of the provisions of Annex VI of the Machinery Directive 2006/42/EC.
- **Markings** have been made in accordance with EN 1550:1997+A1:2008 Section 6.3.1, VDMA 34192:2019 Section 6.3 or ISO 16156:2004 Section 6.3. The requirements of Annex I No. 1.7.3. of the Machinery Directive 2006/42/EC have been complied with.
- the relevant basic and proven safety principles of the Annexes of **ISO 13849-2:2012**, taking into account the requirements of the documentation have been observed for the component. The parameters, limitations, ambient conditions, characteristic values, etc. for proper operation are defined in the operating manual.
- an  $MTTF_D$  value of 150 years can be estimated for mechanical components using the informative procedure in Table C.1 of ISO 13849-1:2015.
- **fault exclusion** against the fault "Unexpected release without pending release signal".
- the **fault exclusion** against the fault "Breakage during operation" in compliance with the parameters, limitations, ambient conditions, characteristic values and maintenance intervals, etc., specified in the operating manual.
- that internal bore diameters in the **pipe or control lines** are at least 2 mm for pneumatic clamping systems and at least 3 mm for hydraulic clamping systems

### Harmonized Standards applied:

- **ISO 12100:2010** Safety of machinery – General principles for design – Risk assessment and risk reduction

### Other related technical Standards and specifications:

- **VDMA 34192:2019** Safety requirements for clamping devices for use on machines

Mengen, 19th of July 2023

*Signature: see original declaration*

*Signature: see original declaration*

p.p. Philipp Schröder  
Head of Development standard products

p.p. Alexander Koch  
Head of Engineering Design special products

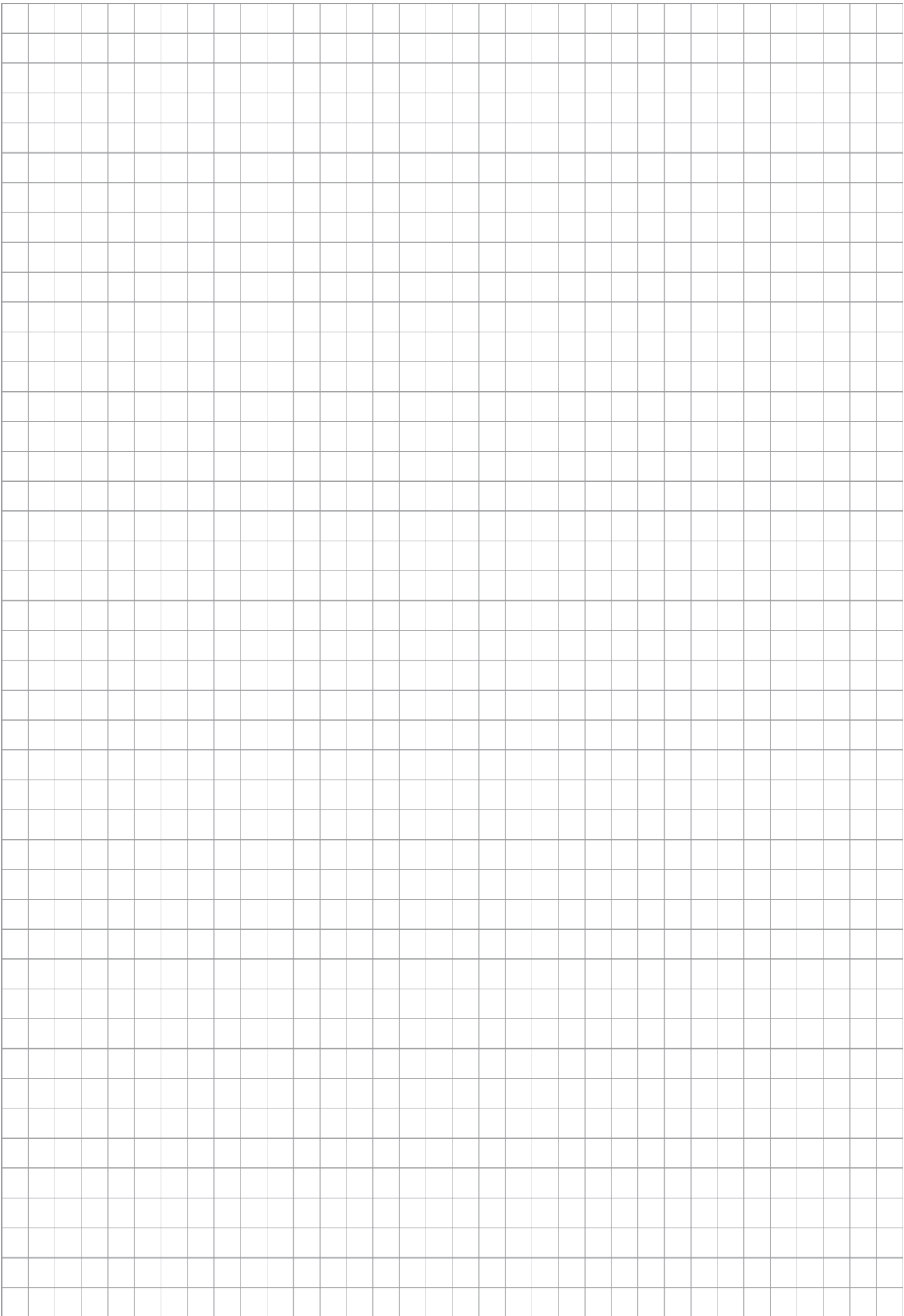

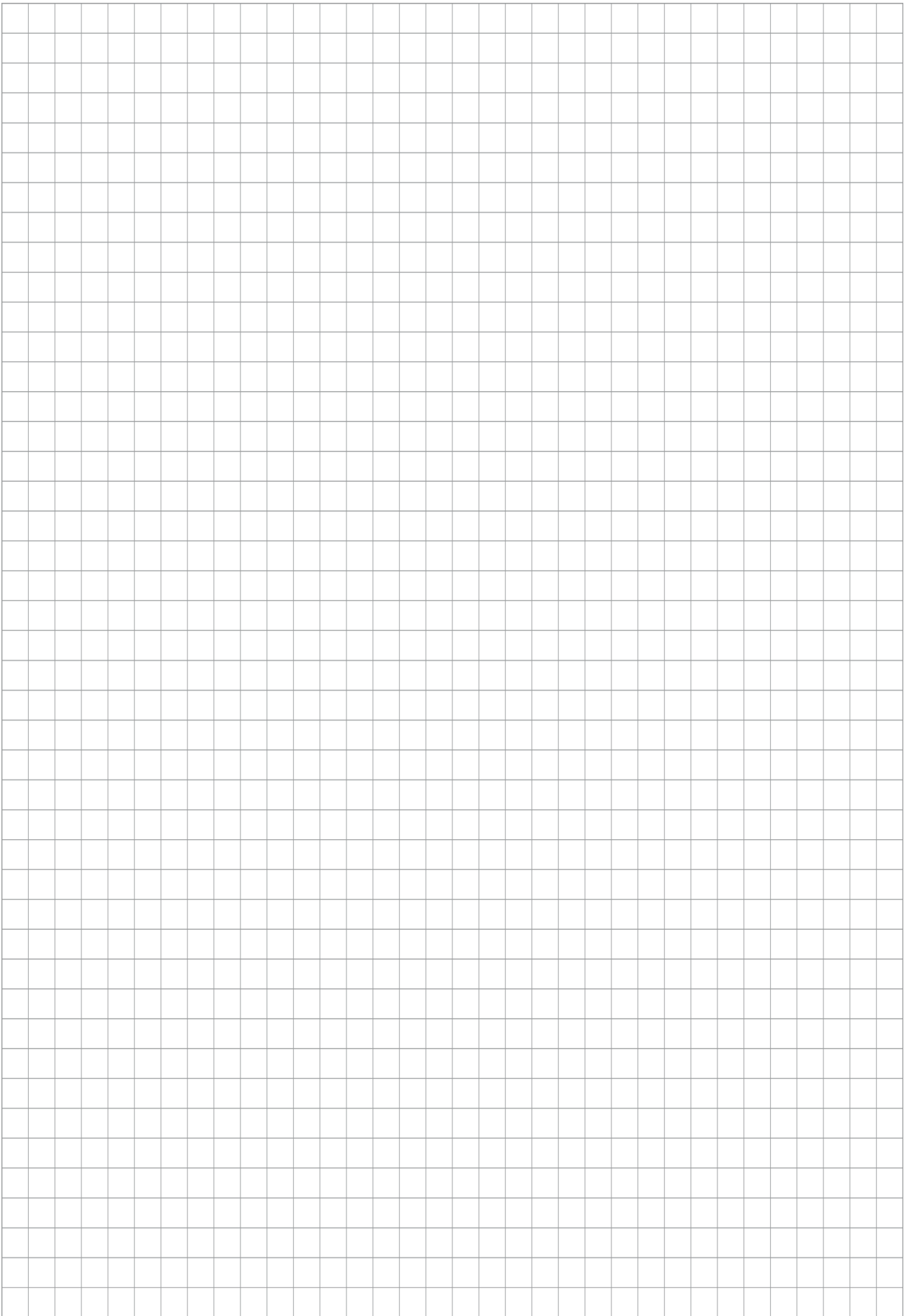





H.-D. SCHUNK GmbH & Co.  
Spanntechnik KG

Lothringer Str. 23  
D-88512 Mengen  
Tel. +49-7572-7614-0  
info@de.schunk.com  
schunk.com

Folgen Sie uns | *Follow us*



Wir drucken nachhaltig | *We print sustainable*